

滚珠丝杠花键篇 Ball Screw with Ball Spline

微型滚珠丝杠花键

Miniature Ball Screw with Ball Spline



由滚珠丝杠制造商和滚珠花键制造商联手打造的混合、紧凑、轻量型产品。
Ball Screw manufacturing company (KSS) and Ball Spline manufacturing company (HEPHAIST) collaborated for developing new product which is focused on Hybrid, Compact and lightweight.

●特点

- 仅使用单件产品,即可实现直动(Z)、旋转(θ)、吸附动作的组合产品。
- 通过微型滚珠丝杠和微型滚珠花键的重叠,最大限度地实现了小型化。

●Features

- This is a combined product which is possible for linear and rotational movement as well as suction at the same time with one unit.
- Achieved developing very compact product as "Overlap type" using Miniature Ball Screws and Miniature Ball Splines.

BSSP分离型 BSSP Separated type

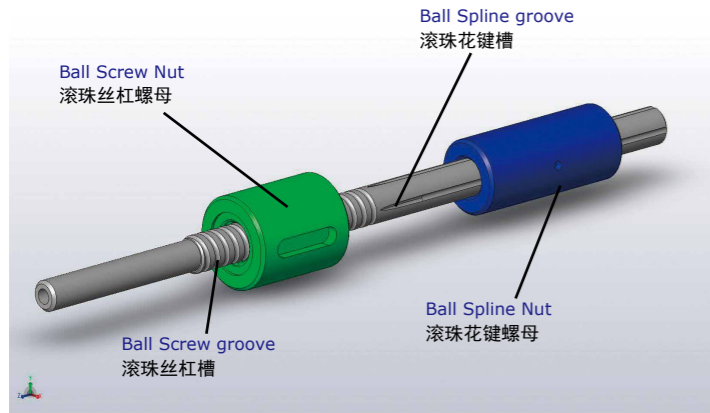

将滚珠丝杠和滚珠花键加工在同一根轴上的组合产品。

It's a combined products, which has Ball Screw and Ball Spline processed on the same Shaft.



BSSP重叠型 BSSP Overlap type

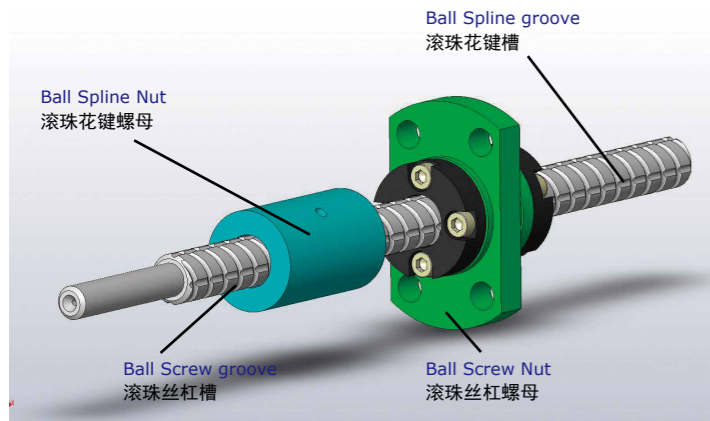

通过将滚珠丝杠和滚珠花键设置在相同的部位,可实现小型化和长行程。

By processing Ball Screw and Ball Spline on the same place makes product have longer travel and compact.



●使用例 Usage example

传送带驱动 Belt Drive

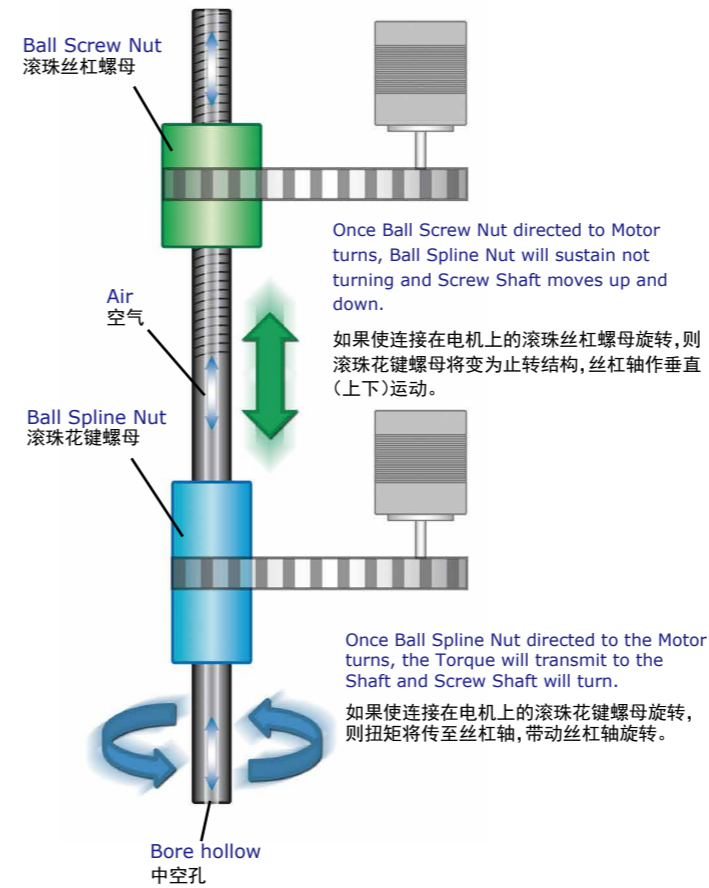

中空电机驱动 Hollow Motor Drive

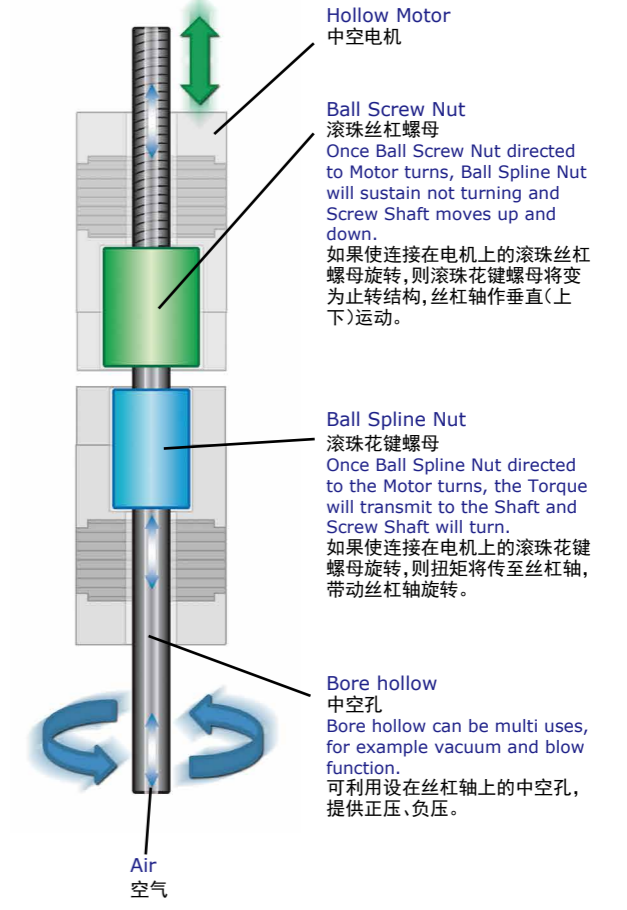

●适用例 Application Example

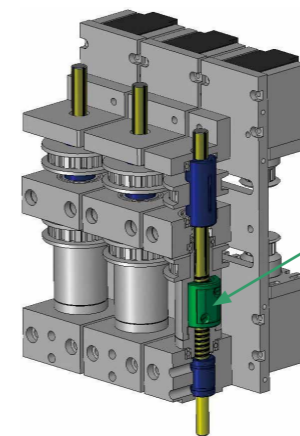

使用分离型,可大大节省空间。最适用于贴片机等用途。

Using "Separated type" of Ball Screw Spline is suitable for downsizing devices and equipment. Suitable for Chip-Mounter application etc.

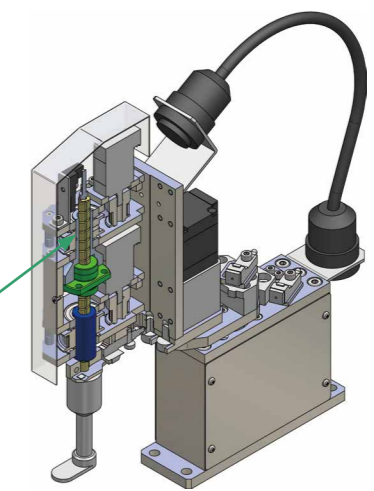

使用重叠型,可确保长行程并实现小型化设计。最适用于小型Scalar机器人的前端部组件等。

Using "Overlap type" can save Shaft length and makes device as minimized as possible. For example, suitable for Miniature SCARA Robot, especially for the head part.

●规格 Specifications

1) 精度等级和间隙

微型滚珠丝杠花键(BSSP)的精度等级和间隙(轴向间隙、径向间隙)如下表所示。

1) Accuracy Grade & Axial/Radial play

Accuracy grade and Axial/Radial play for BSSP are shown in Table below.

Unit(单位):mm

Type 类型	Part 部位	C3 (Maximum / 最大)		C5 (Maximum / 最大)
Separated type 分离型	Ball Screw / 滚珠丝杠 (Axial play / 轴向间隙)	0 or 0.005		0.005
	Ball Spline / 滚珠花键 (Radial play / 径向间隙)	0		
Overlap type 重叠型	Ball Screw / 滚珠丝杠 (Axial play / 轴向间隙)	0.005		0.002
	Ball Spline / 滚珠花键 (Radial play / 径向间隙)	0.002		

2) 滚珠丝杠花键安装部的精度

微型滚珠丝杠花键(BSSP)的安装部精度依据JIS B1192-3(滚珠丝杠)、JIS B1193(滚珠花键),按以下标示方法和规格制造。

2) Run-out and location tolerances for BSSP

Run-out and location tolerances for BSSP are based on JIS B1192-3(Ball Screw), JIS B1193(Ball Spline).

Tolerance for each part and description are as follows.

【分离型 / Separated type】

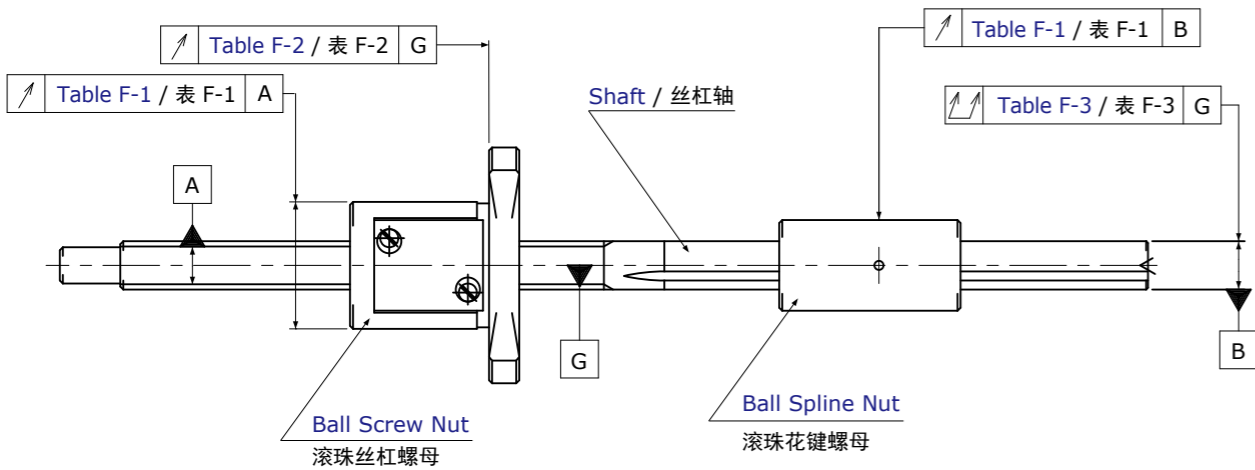

【重叠型 / Overlap type】



表 F-1 : 相对于丝杠轴轴线的螺母外周面的半径方向圆跳动

Table F-1 : Radial Run-out of Ball Nut location diameter related to the centerline of Screw Shaft

Unit(单位): μm

Nut outside diameter 螺母外径 (mm)		Permissible deviation of Radial Run-out 跳动公差(最大)		
Over 超过	Up to 以下	Ball Screw Nut / 滚珠丝杠螺母		Ball Spline Nut 滚珠花键螺母
		C3	C5	
—	20	9	12	11
20	32	10	12	—

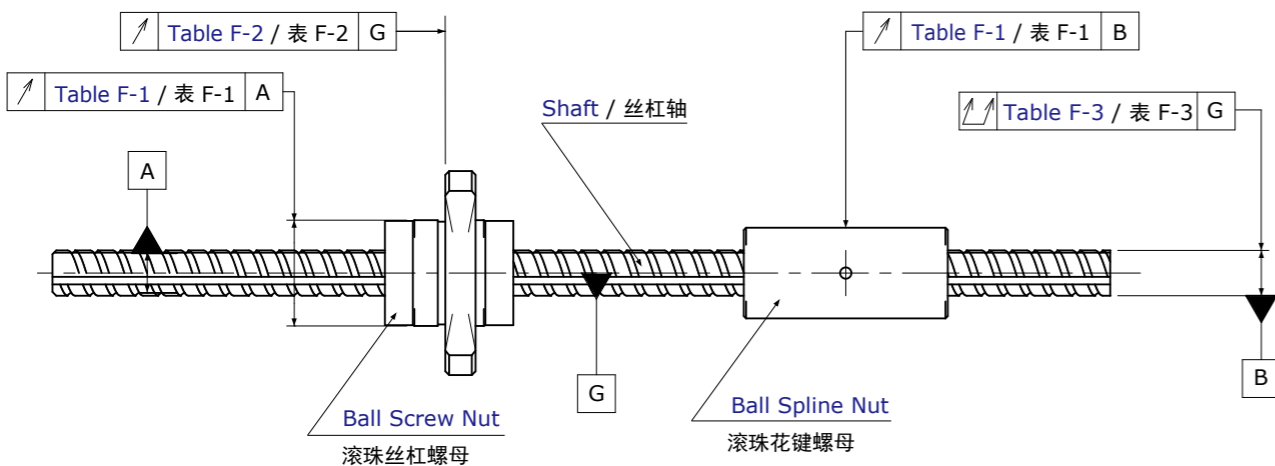
表 F-2 : 相对于丝杠轴轴线的滚珠丝杠螺母基准端面或法兰安装面的圆跳动

Table F-2 : Axial Run-out (Perpendicularity) of Ball Nut location face related to the centerline of Screw Shaft

Unit(单位): μm

Nut outside diameter 螺母外径 (mm)		Permissible deviations of Axial Run-out(Perpendicularity) 跳动公差(最大)	
Over 超过	Up to 以下	Ball Screw Nut / 滚珠丝杠螺母	
		C3	C5
—	20	8	10
20	32	8	10

表 F-3 : 丝杠轴轴线的半径方向全跳动

Table F-3 : Total Run-out in radial direction of Screw Shaft related to the centerline of Screw Shaft

Unit(单位): μm

Shaft total length 丝杠轴总长 (mm)		Permissible deviations of total Run-out in radial direction 跳动公差(最大)	
Over 超过	Up to 以下	C3	C5
		—	125
125	200	35	50
200	315	50	65

3) 滚珠丝杠部的导程精度 / Lead accuracy of Ball Screws

滚珠丝杠的导程精度根据相对于螺纹部有效长度的代表移动量误差($\pm e_p$)及波动(V_u)来确定。不同精度等级的许用值详见表F-4。

Ball Screw lead accuracy is specified by the tolerance of actual mean travel error ($\pm e_p$) and travel variation (V_u) over the Screw Shaft effective length.

Tolerance of each accuracy grades are shown in the Table F-4.

表 F-4 : 滚珠丝杠的代表移动量误差($\pm e_p$)和波动(V_u)许用值

Table F-4 : Tolerance on Specified travel ($\pm e_p$) and permissible travel variation of Ball Screws.

Unit(单位): μm

Accuracy Grade 精度等级	C3		C5	
	Over 超过	Up to 以下	$\pm e_p$	V_u
Effective screw length 螺纹部有效长度 (mm)	—	100	8	8
	100	200	10	8
	200	315	12	8

4) 材质和热处理、硬度

微型滚珠丝杠花键(BSSP)的标准材质、热处理和硬度如表 F-5所示。
表中数值可能会因轴、螺母的形状不同而略有差异,详情请参照本公司出示的规格图。

表 F-5 : 一般产品的材质和热处理、硬度
Table F-5 : Material, Heat treatment & Surface hardness

		Material 材质	Heat treatment 热处理	Surface hardness 表面硬度
Screw Shaft 丝杠轴	Solid Shaft 实心轴	SCM415	Carburizing and quenching 渗碳淬火	HRC 58-62
	Hollow Shaft 空心轴	SUJ2	Induction hardening 高频淬火	
Nut / 螺母		SCM415	Carburizing and quenching 渗碳淬火	HRC 58-62

5) 润滑

使用滚珠丝杠花键(BSSP)时,必须涂抹润滑剂。否则会造成扭矩变大或缩短丝杠使用寿命等问题。涂抹润滑剂可以抑制因摩擦而导致的升温、机械效率下降,以及因磨损而导致的精度下降。使用油脂润滑BSSP时,一般建议使用锂皂基油脂;使用油润滑时,建议使用ISO VG32~68(透平油)。如无特别指定,滚珠丝杠花键(BSSP)在交货时会涂上防锈油。由于防锈油不具备润滑性,因此在使用前请另行涂抹润滑剂。如无特殊要求,建议使用KSS原装润滑油脂(MSG No.2)。也可在出厂时涂抹客户要求的油脂。

4) Material & Heat treatment, Surface hardness

Standard material of BSSP, Heat treatment and Surface hardness are shown in Table F-5. However, they vary depending on profile of Shaft or Nut. Please refer to KSS drawings.

5) Lubrication

In Ball Screw with Ball Spline(BSSP) use, lubricant should be required. If lubricant is not applied with, the problem such as increase of Torque and shortened Life occurs. Applying lubricant can minimize temperature increases, decline of mechanical efficiency due to friction, and deterioration of accuracy caused by wear. For lubrication of BSSP, regular lithium-soap-based Grease and ISO VG32-68 Oil (turbine Oil #1 to #3) are recommended. BSSP are applied with anti-rust oil for rust prevention, if there is no designation when shipping. Since anti-rust oil is not lubricant, apply Grease or Lubrication oil before using BSSP. If there is no specific request, KSS would recommend our original grease (MSG No.2) as standard lubricant. We can apply designated Grease before shipping, please ask KSS representative.

表 F-6 : 一般使用条件下的润滑剂示例
Table F-6 : Recommended lubricants for normal operating conditions

Lubricant 润滑剂	Type 种类	Product name 产品名称
Grease 油脂	Lithium-based Grease 锂基油脂	KSS original Grease MSG No.2 KSS原装油脂 MSG No.2
Lubricating Oil 润滑油	Sliding surface Oil or turbine Oil 滑动面油或透平油	Super Multi 68 Super Multi68

6) 花键螺母的安装

利用设在螺母外周的销孔以及粘接剂来安装滚珠花键螺母。使用销孔安装时,请注意不要使花键螺母承受负载。

6) Mounting of Ball Spline Nut

Ball Spline Nut should be mounted using pin-hole located on Nut outer, and adhesive. Please make sure that no load would be applied on pin when using pin-hole.

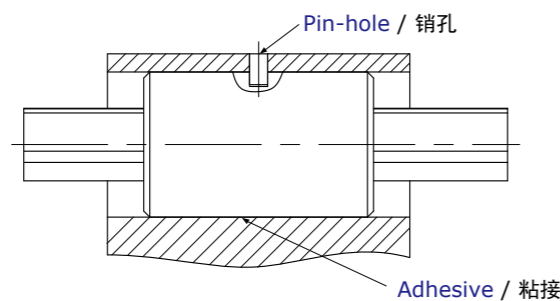

7) 滚珠丝杠螺母的安装

通过螺母旋转的方式来使用滚珠丝杠时,可以通过托架将轴承安装到螺母上,也可以将轴承直接组装到螺母外径上。可根据客户的安装需求变更滚珠丝杠螺母的设计,详情请垂询本公司。

7) Mounting of Ball Screw Nut

There would be a couple of ways to install Bearings onto Ball Screw Nut, such as using Bracket as Bearing shaft, direct mounting on Ball Screw Nut. KSS designs special profile of Ball Screw Nut in accordance with customer's mounting request. Please ask KSS representative for further information.

通过托架安装轴承
Brg. install with Bracket

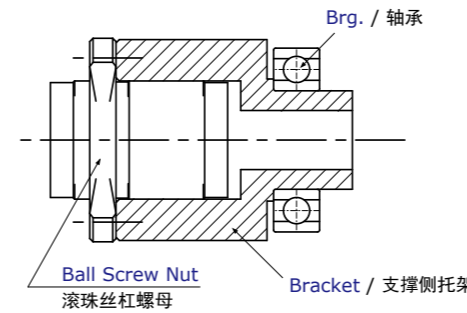

将轴承直接安装到螺母外径上
Direct install of Brg. onto Nut outer

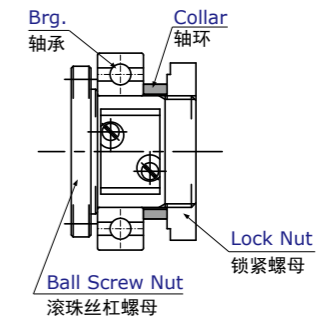

● 公称型号的构成 Model number notation

【分离型 / Separated type】

BSSP 06 10 / 06 - 080 R 070 S 200 C5 T

① ② ③ ④ ⑤ ⑦ ⑧ ⑨ ⑩ ⑪ ⑫

【重叠型 / Overlap type】

BSSP 06 10 - 150 R 180 C5 T

① ② ③ ⑥ ⑦ ⑩ ⑪ ⑫

- ① 系列符号 BSSP : 滚珠丝杠花键
- ② 丝杠轴公称外径(mm)
- ③ 导程(mm)
- ④ 花键轴径(mm)
- ⑤ 滚珠丝杠部有效长度(mm)
- ⑥ 滚珠丝杠 / 滚珠花键有效长度(mm)
- ⑦ 滚珠丝杠旋向(R=右旋, L=左旋)
- ⑧ 滚珠花键部有效长度(mm)
- ⑨ 滚珠花键部的符号
- ⑩ 丝杠轴总长(mm)
- ⑪ 精度等级
- ⑫ 轴形状 无符号: 实心轴, T: 空心轴

- ① Ball Screw with Ball Spline series No.
BSSP : Ball Screw with Ball Spline
- ② Screw Shaft nominal diameter(mm)
- ③ Lead(mm)
- ④ Ball Spline Shaft nominal diameter(mm)
- ⑤ Screw thread length(mm)
- ⑥ Screw thread & Spline length(mm)
- ⑦ Thread direction(R=Right-hand, L=Left-hand)
- ⑧ Spline length(mm)
- ⑨ S means Ball Spline part
- ⑩ Total length(mm)
- ⑪ Accuracy grade
- ⑫ Shaft option : No indication=solid shaft, T=Hollow shaft

BSSP0610

Shaft dia.(轴径) $\phi 6$ Lead(导程)10mm

C5

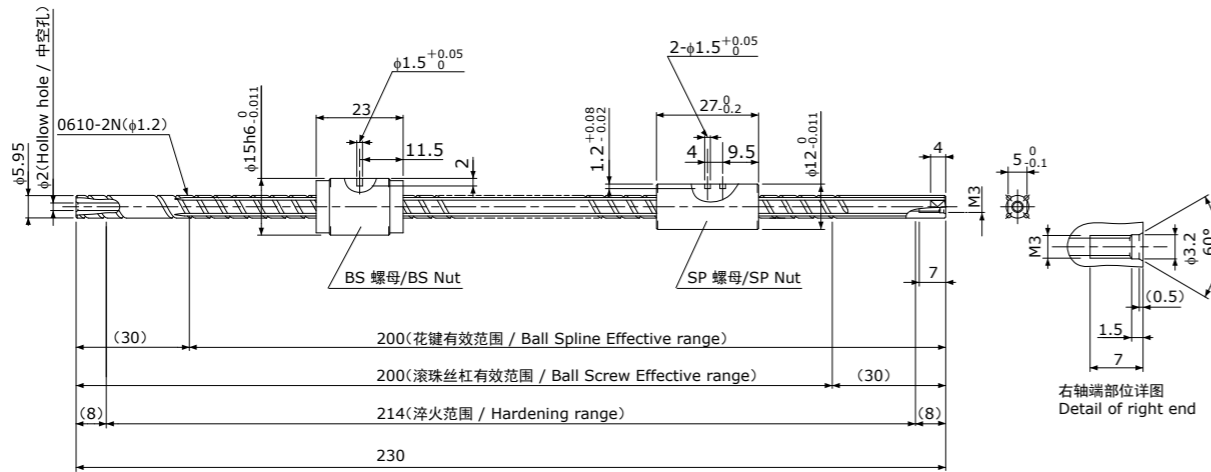

BSSP0810

Shaft dia.(轴径) $\phi 8$ Lead(导程)10mm

C5

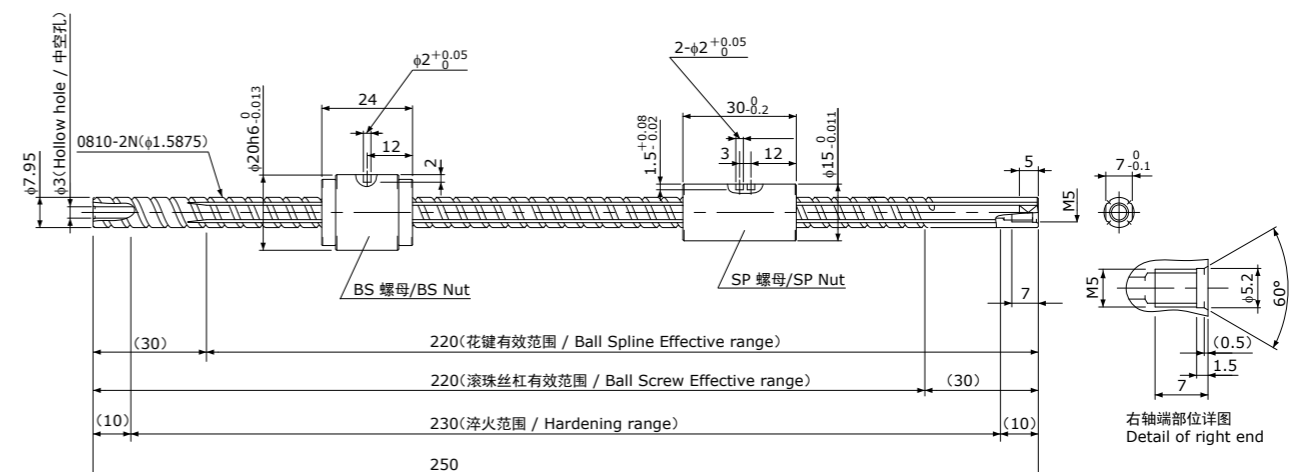

Ball Screw Specifications 滚珠丝杠主要技术参数	
Accuracy Grade 精度等级	JIS C5
Ball size 钢珠直径	$\phi 1.2$ mm
Number of thread 螺纹条数	2
Thread direction 螺纹旋向	Right 右
Pitch circle dia. 节圆直径	6.30mm
Number of circuit 循环数	1.2×2
Dynamic Basic Load Rating 基本额定动负载 C_a	(650N)
Static Basic Load Rating 基本额定静负载 C_{oa}	(900N)
Axial Play 轴向间隙	Max 0.005 mm

Ball Spline Specifications 滚珠花键主要技术参数	
Accuracy Grade 精度等级	JIS C5
Dynamic Basic Load Rating 基本额定动负载 C_r	(750N)
Static Basic Load Rating 基本额定静负载 C_{or}	(1200N)
Dynamic Basic Torque Rating 基本额定动扭矩 C_t	(1.9 Nm)
Static Basic Torque Rating 基本额定静扭矩 C_{ot}	(1.3 Nm)
Radial Play 径向间隙	Max 0.002 mm

Common Specifications 通用技术参数		
Material 材质	Shaft 轴	SUJ2
	Nut 螺母	SCM415
Anti-rust treatment 防锈处理	Anti-rust Oil 防锈油	

Note 1) The detail will be provided by drawing.
Note 2) Female thread on left end journal is not available.
注1) 详情记载于规格图中。
注2) 不进行轴端内螺纹的追加加工。

【轴端追加加工/Re-works on Shaft-end】

Other parts can be attached by re-working the end journal, such as turning down, or male thread.

通过对轴端进行切断及追加加工(车削、外螺纹加工), 使得部件得以安装。

轴端追加加工例 / Re-works Example

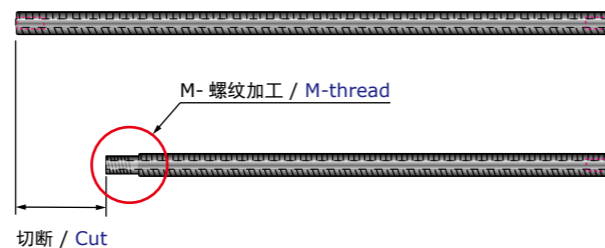

Ball Screw Specifications 滚珠丝杠主要技术参数	
Accuracy Grade 精度等级	JIS C5
Ball size 钢珠直径	$\phi 1.5875$ mm
Number of thread 螺纹条数	2
Thread direction 螺纹旋向	Right 右
Pitch circle dia. 节圆直径	8.40mm
Number of circuit 循环数	1.65×2
Dynamic Basic Load Rating 基本额定动负载 C_a	(1400N)
Static Basic Load Rating 基本额定静负载 C_{oa}	(2000N)
Axial Play 轴向间隙	Max 0.005 mm

Ball Spline Specifications 滚珠花键主要技术参数	
Accuracy Grade 精度等级	JIS C5
Dynamic Basic Load Rating 基本额定动负载 C_r	(1000N)
Static Basic Load Rating 基本额定静负载 C_{or}	(1450N)
Dynamic Basic Torque Rating 基本额定动扭矩 C_t	(3.4Nm)
Static Basic Torque Rating 基本额定静扭矩 C_{ot}	(2.4Nm)
Radial Play 径向间隙	Max 0.002 mm

Common Specifications 通用技术参数		
Material 材质	Shaft 轴	SUJ2
	Nut 螺母	SCM415
Anti-rust treatment 防锈处理	Anti-rust Oil 防锈油	

Note 1) The detail will be provided by drawing.
Note 2) Female thread on left end journal is not available.
注1) 详情记载于规格图中。
注2) 不进行轴端内螺纹的追加加工。

【轴端追加加工/Re-works on Shaft-end】

Other parts can be attached by re-working the end journal, such as turning down, or male thread.

通过对轴端进行切断及追加加工(车削、外螺纹加工), 使得部件得以安装。

轴端追加加工例 / Re-works Example

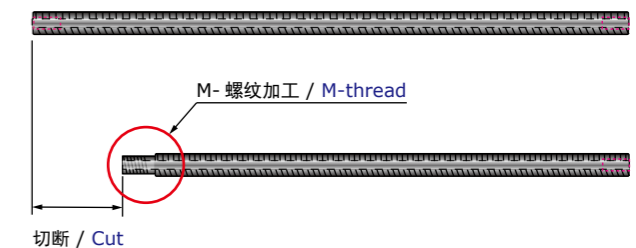

Separated type 分离型

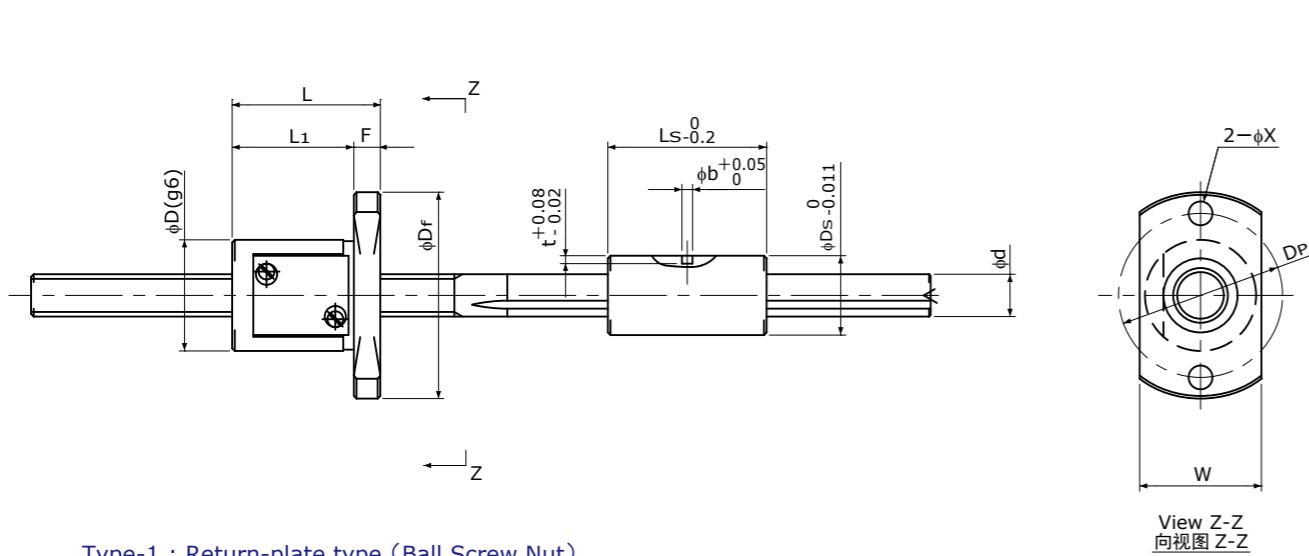

Type-1 : Return-plate type (Ball Screw Nut)
复式回路板循环方式(滚珠丝杠螺母)

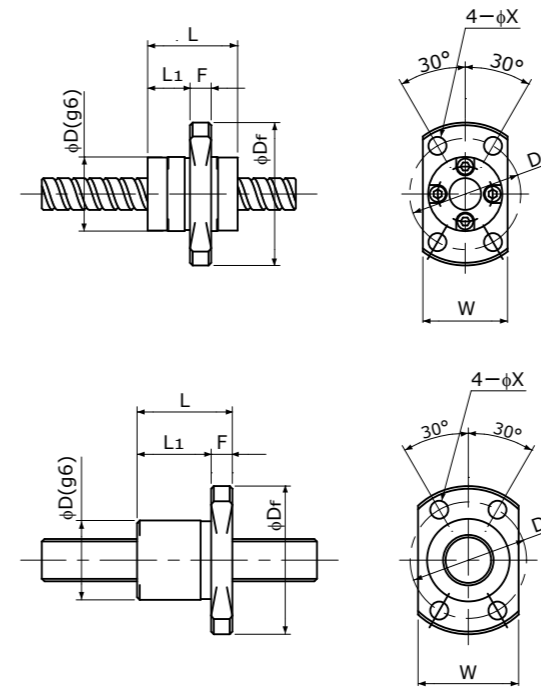

Type-2 : End-cap type (Ball Screw Nut)
端盖式循环方式(滚珠丝杠螺母)

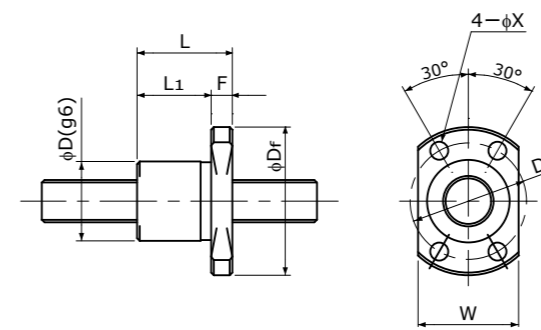

Type-3 : Internal-deflector type (Ball Screw Nut)
陀螺式循环方式(滚珠丝杠螺母)

Unit(单位):mm

Ball Nut Model number 螺母型号	Shaft nominal dia. 丝杠轴公称外径 d	Lead 导程	Ball Screw part / 滚珠丝杠部											Ball Spline part / 滚珠花键部								Bore hollow 中空孔	Shaft Inertia 丝杠轴惯量 Kgm ² /mm	Ball Nut Model number 螺母型号			
			Basic Load Rating 基本额定负载 (Reference) (参考值)		Nut dimension / 螺母尺寸											Basic Load Rating 基本额定负载 (Reference) (参考值)		Basic Torque Rating 基本额定扭矩 (Reference) (参考值)		Permissible Moment 允许力矩 (Ref.) (参考值) Mo Nm	Nut dimension / 螺母尺寸						
			Ca	Coa	Nut type 螺母类型	Nut mass 螺母质量 g	D	Dr	L	L1	F	W	Dp	Bolt Hole 安装孔 X	Cr	Cor	Ct	Cot	Nut mass 螺母质量 g		OD. 外径 Ds				Length 长度 Ls	Pin hole 销孔	
			N	N																						N	N
BSSP 0602/06	6	2	(750)	(1200)	1	25	15	29	17	13	4	17	23	3.4	(860)	(1400)	(2.2)	(1.6)	(3.0)	14	12	27	1.5	1.2	2	9.99×10 ⁻¹⁰	BSSP 0602/06
BSSP 0606/06		6	(870)	(1450)	2	20	14	27	17	8	4	16	21	3.4													BSSP 0606/06
BSSP 0610/06		10	(950)	(1600)	2	20	14	27	23	11.5	4	16	21	3.4													BSSP 0610/06
BSSP 0802/08(1)	8	2	(850)	(1600)	1	25	16	30	17	13	4	18	24	3.4	(1200)	(1900)	(4.1)	(3.1)	(4.1)	22	15	30	2.0	1.5	3	31.6×10 ⁻¹⁰	BSSP 0802/08(1)
BSSP 0802/08(2)		2	(2400)	(4000)	1	60	20	38	24	19	5	22	30	4.5													BSSP 0802/08(2)
BSSP 0802/08(3)		2	(1300)	(2300)	3	25	15	28	18	14	4	17	22	3.4													BSSP 0802/08(3)
BSSP 0804/08		4	(2600)	(4200)	1	75	21	39	28	23	5	23	31	4.5													BSSP 0804/08
BSSP 0812/08		12	(2200)	(4000)	2	40	18	31	27	17	4	20	25	3.4													BSSP 0812/08

- 注1) 中空孔为选购件。根据丝杠轴的长度,也可能不适用。
- 注2) 需要特殊的螺母形状时,请垂询本公司。
- 注3) 基本额定负载,基本额定扭矩、允许力矩是根据有效负载滚珠数量计算出的理论值。根据不同的使用条件会发生很大变化,请仅作为参考。
- 注4) 本产品是承受径向负载的滚珠花键和承受轴向负载的滚珠丝杠的组合产品,很难预估其理论寿命。建议使用实机进行评估,或根据本公司的实验数据来判断是否适用。
- 注5) 可生产的最大长度为max.150mm(f6)、max.200mm(f8)。需要超过上述长度的产品时,请垂询本公司。

- Note 1) Please note that Bore hollow is an option, not a standard. In some cases Bore hollow is not available due to Shaft length.
- Note 2) If special profile of Ball Screw Nut / Ball Spline Nut, please ask KSS representative.
- Note 3) Basic Load Rating, Basic Torque Rating and Permissible Moment are theoretical number based on effective number of Balls. They may vary drastically depending on operating condition. Please consider them just reference.
- Note 4) It is difficult to estimate theoretical life, because of combined products with Ball Spline which withstands Radial Load and Ball Screw for Axial Load. We would recommend that final decision should be based on your evaluation on actual machine or our experimental data.
- Note 5) Maximum limit of Shaft length is 150mm(for f6), 200mm(for f8). Please ask KSS in case of exceeding limit length.

Overlap type 重叠型

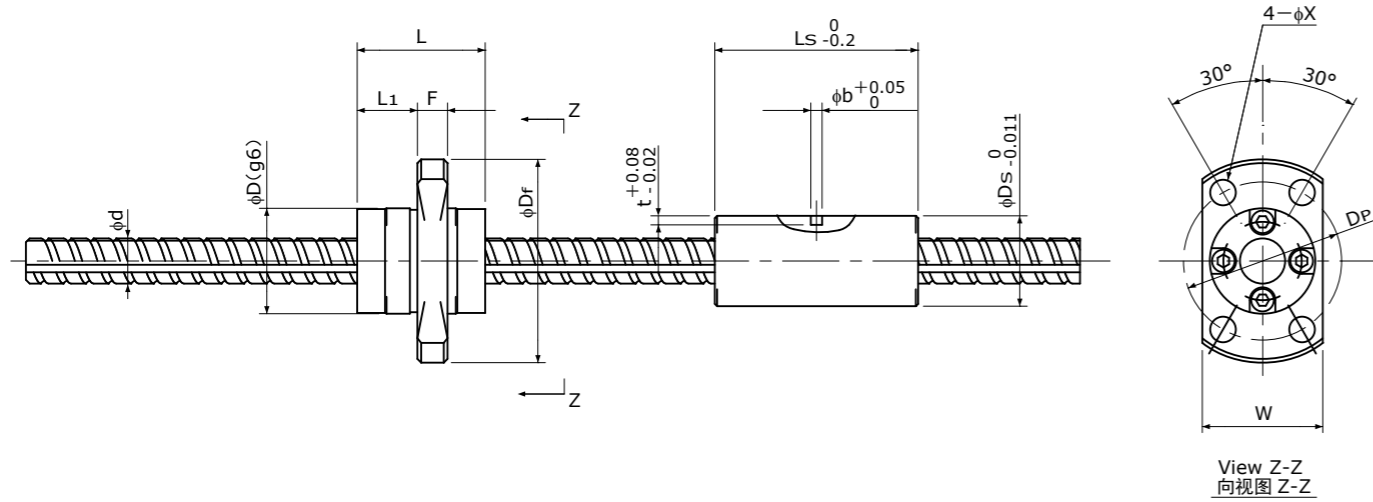

Type-2 : End-cap type(Ball Screw Nut) 端盖式循环方式(滚珠丝杠螺母)

Unit(单位):mm

Ball Nut Model number 螺母型号	Shaft nominal dia. 丝杠轴公称外径 d	Lead 导程	Ball Screw part / 滚珠丝杠部											Ball Spline part / 滚珠花键部					Bore hollow 中空孔	Shaft Inertia 丝杠轴惯量 Kgmm ² /mm	Ball Nut Model number 螺母型号						
			Basic Load Rating 基本额定负载 (Reference) (参考值)		Nut dimension / 螺母尺寸										Basic Load Rating 基本额定负载 (Reference) (参考值)		Basic Torque Rating 基本额定扭矩 (Reference) (参考值)					Permissible Moment 允许力矩 (Ref.) (参考值) Mo Nm	Nut dimension / 螺母尺寸				
			Ca	Coa	Nut type 螺母类型	Nut mass 螺母质量	D	Dr	L	L1	F	W	Dp	Bolt Hole 安装孔 X	Cr	Cor	Ct	Cot					Nut mass 螺母质量 g	OD. 外径 Ds	Length 长度 Ls	Pin hole 销孔	
BSSP 0606	6	6	(600)	(900)	2	20	14	27	17	8	4	16	21	3.4	(650)	(1000)	(1.7)	(1.2)	(2.2)	14	12	27	1.5	1.2	2	9.99×10 ⁻¹⁰	BSSP 0606
BSSP 0610		10	(650)	(900)	2	20	14	27	23	11.5	4	16	21	3.4	(750)	(1200)	(1.9)	(1.3)	(2.4)								BSSP 0610
BSSP 0812	8	12	(1400)	(2000)	2	40	18	31	27	17	4	20	25	3.4	(1100)	(1700)	(3.8)	(2.8)	(2.7)	22	15	30	2.0	1.5	3	31.6×10 ⁻¹⁰	BSSP 0812

- 注1) 中空孔为选购件。根据丝杠轴的长度,也可能不适用。
- 注2) 需要特殊的螺母形状时,请垂询本公司。
- 注3) 基本额定负载、基本额定扭矩、允许力矩是根据有效负载滚珠数量计算出的理论值。根据不同的使用条件会发生很大变化,请仅作为参考。
- 注4) 本产品是承受径向负载的滚珠花键和承受轴向负载的滚珠丝杠的组合产品,很难预估其理论寿命。建议使用实机进行评估,或根据本公司的实验数据来判断是否适用。
- 注5) 作为参考,本产品的可搬重量最大为10N。
- 注6) 可生产的最大长度为max.150mm(f6)、max.200mm(f8)。需要超过上述长度的产品时,请垂询本公司。

- Note 1) Please note that Bore hollow is an option, not a standard. In some cases Bore hollow is not available due to Shaft length.
- Note 2) If special profile of Ball Screw Nut / Ball Spline Nut, please ask KSS representative.
- Note 3) Basic Load Rating, Basic Torque Rating and Permissible Moment are theoretical number based on effective number of Balls. They may vary drastically depending on operating condition. Please consider them just reference.
- Note 4) It is difficult to estimate theoretical life, because of combined products with Ball Spline which withstands Radial Load and Ball Screw for Axial Load. We would recommend that final decision should be based on your evaluation on actual machine or our experimental data.
- Note 5) Maximum Load Capacity should be considered 10N.
- Note 6) Maximum limit of Shaft length is 150mm(for f6), 200mm(for f8). Please ask KSS in case of exceeding limit length.

●存放、操作及使用注意事项

·操作注意事项

BSSP属于精密部件,请遵照下述事项谨慎操作。

存放

存放时,请保持本公司原装包装状态。

请勿随意开包或弄破内部包装。

否则会有异物进入或生锈,从而导致产品性能下降。

请避免将产品保管在80℃以上、-20℃以下、湿度为80%以上的潮湿环境中,应在不会结露的环境中以水平状态保管。

操作

1. 严禁拆分产品。否则会导致异物进入、精度下降或引发事故。
2. 重新组装时,如果组装错误,可能会导致滚珠丝杠的功能丧失。因此,客户请勿自行重新组装。请将产品送回本公司,我们将有偿为您维修并重新组装。
3. BSSP的轴和螺母可能会因自重而下落,请注意避免受伤。
4. 如果BSSP下落,循环部件、轴的外径以及钢珠等可能会划伤、损坏。这可能会导致产品功能丧失,如回转不良等。若BSSP下落,必须由本公司进行检查。请务必将产品送回本公司。我们将有偿为您检查。

·使用注意事项

防尘

请在清洁环境下使用BSSP。

请同时使用防尘罩等防止异物、切屑等进入BSSP中。

如果因防尘不当而导致异物、切屑等进入BSSP,可能会降低滚珠丝杠的性能或损坏循环部件,从而导致产品锁死。

润滑

请在使用前确认润滑状况。如果润滑不良,可能会导致BSSP在短期内丧失功能。

防锈油并非润滑剂,使用前请用精制煤油等清洗滚珠丝杠,

去除防锈油后涂上润滑剂(油脂或润滑油)。在常规用途下使用时,请每2~3个月检查一次油脂。

使用过程中油脂变脏时,请擦去旧的油脂后涂抹新油脂。

许用转速和许用径向负载

根据尺寸、材质及安装方式等不同,BSSP会受到轴向负载和转速的限制。建议在产品的设计阶段就使用条件与本公司充分协商。

超程

滚珠丝杠螺母发生超程时,可能导致钢珠脱落、循环部件受损或钢珠槽产生压痕等,从而引起动作不良。

如果在该状态下继续使用,还可能导致早期磨损或循环部件损坏。因此请务必避免超程。

发生超程时,请与本公司联系检查事宜。我们将有偿为您检查。

使用温度

使用温度的极限通常设计在-20℃以上、80℃以下;湿度为80%以下。

超过该温度使用时,可能会产生如下现象:

- BSSP循环性能下降;
- 循环部件损伤或损坏;
- 相对于热处理部位的硬度降低;
- BSSP各部件的腐蚀。

如需在超过上述条件的环境下使用,请垂询本公司。

偏负载

滚珠丝杠螺母是一种产生轴向推力的机械元件,其结构不能承受径向负载和力矩负载。

如果滚珠丝杠承受径向负载或力矩负载,将会导致滚珠负载不均,从而显著缩短产品的使用寿命。

请注意避免对滚珠丝杠螺母部施加径向负载和力矩负载。

●Precaution of storage, handling and operating

· Precaution for handling

BSSP is precision components, and must be handled carefully in accordance with the instruction below.

Storage

BSSP should be stored unopened in their original KSS packaging. Avoid opening the package or breaking the inner package unnecessarily. This may result in contamination or rusting, and may degrade operating performance.

Please store BSSP under -20℃ ~80℃, less than 80%RH humidity without any dew condensation.

Handling

1. Never disassemble BSSP. This will cause contamination, reduce accuracy, and lead to accidents.
2. Customers should not attempt to reassemble BSSP. Incorrect reassembly can easily result in malfunction. BSSP should be returned to KSS, where it will be repaired and reassembled with charge.
3. Take care to avoid injuries due to falling BSSP Shaft or Nut.
4. Dropping BSSP may cause scratching or impact damage to recirculating components, Shaft outside diameters, Balls, or Screw & Spline grooves, which may cause malfunction, such as incorrect rotation. If dropped, BSSP must be inspected by KSS with charge. Please make sure you return dropped Shaft or Nut.

· Precaution for operating

Dust proof

Ball Screws must be used in a clean environment. They should be used with a dustproof cover to prevent contamination from dust or swarf. Dust or swarf contamination due to insufficient dust protection may reduce the BSSP performance, cause damage to recirculating components, which lead to locking.

Lubrication

Check lubrication before use. Insufficient lubrication will rapidly deteriorate the operating performance of BSSP. Since anti-rust oil is not lubricant(Grease / Oil), Anti-rust oil on BSSP should be washed off with clean Kerosene and apply lubricant before using BSSP.

Please check the lubricant condition every 2 to 3months. If Grease is contaminated, remove old Grease, and replace with new Grease.

Critical speed and Permissible Axial load

BSSP has the maximum limit of speed and Axial load depending on its size, material, mounting method etc.

When design BSSP, KSS would recommend that you consult with KSS engineering about the operating condition and model selection.

Over-run

Allowing Nuts to overrun may result in malfunctioning due to Balls escaping, damage to recirculation components, and indentation of the Ball grooves. Continued use in this state will lead to rapid wear and damage to recirculation components. Ball Screw Nut and Ball Spline Nut must therefore never be allowed to overrun. If overrunning occurs, contact KSS for an inspection with charge.

Temperature

BSSP should be used under the temperature of -20℃ ~80℃, and humidity of less than 80%RH.

Avoid use BSSP under lower / higher temperatures and higher humidity.

This may result in the following problems.

- Reduced performance of Ball recirculation, and smooth movement.
- Damage to recirculation components.
- Reduced hardness of heat treated components.
- Rust on BSSP components.

If it is necessary to work beyond the recommended temperatures, please consult with KSS first as we may be able to provide a solution.

Moment load or Radial load

Ball Screw Nut primarily generate thrusts in the axial direction, and are not designed to withstand Radial loads and Moment loads. Care must be taken not to apply Radial loads and Moment loads to the Ball Screw Nut. If these kinds of loads act on the Ball Screws, Ball load uniformity is lost, and the life of Ball Screws is drastically reduced.