

Ball Screw with Ball Spline 滚珠丝杠花键

Separated type 分离型

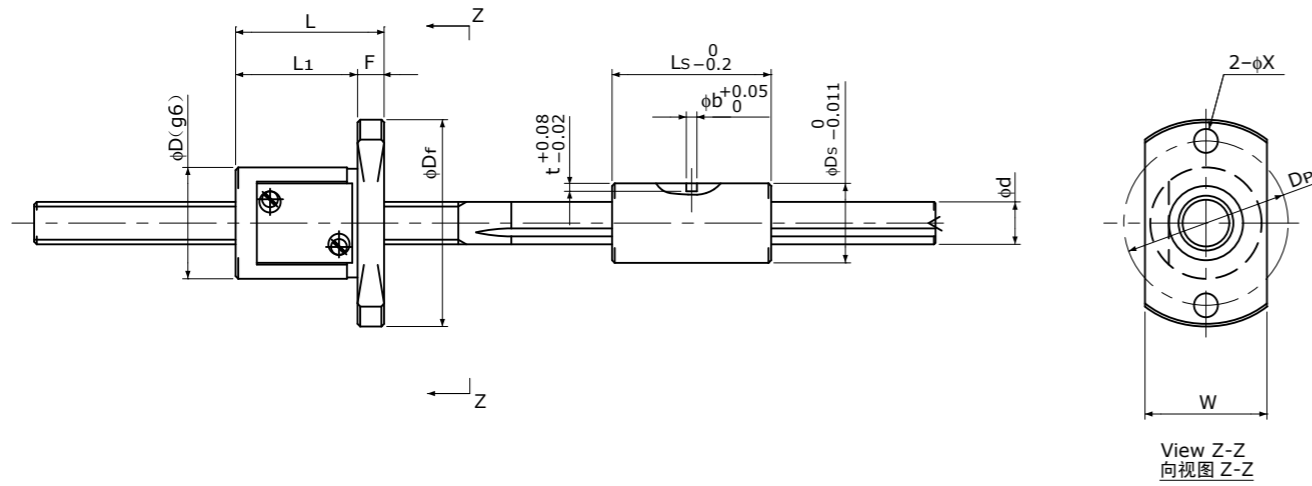

Type-1 : Return-plate type (Ball Screw Nut)
复式回路板循环方式 (滚珠丝杠螺母)

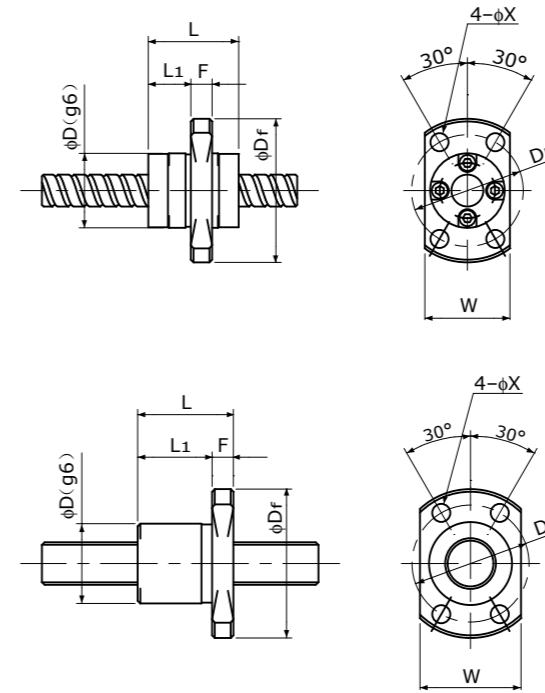

Type-2 : End-cap type (Ball Screw Nut)
端盖式循环方式 (滚珠丝杠螺母)

Type-3 : Internal-deflector type (Ball Screw Nut)
陀螺式循环方式 (滚珠丝杠螺母)

Unit (单位) : mm

Ball Nut Model number 螺母型号	Shaft nominal dia. 丝杠轴公称外径 d	Lead 导程	Ball Screw part / 滚珠丝杠部											Ball Spline part / 滚珠花键槽								Bore hollow 中空孔	Shaft Inertia 丝杠轴惯量	Ball Nut Model number 螺母型号			
			Basic Load Rating 基本额定负载 (Reference) (参考值)		Nut dimension / 螺母尺寸											Basic Load Rating 基本额定负载 (Reference) (参考值)		Basic Torque Rating 基本额定扭矩 (Reference) (参考值)		Permissible Moment 许用扭矩 (Ref.) (参考值) Mo	Nut dimension / 螺母尺寸						
			Ca N	Coa N	Nut type 螺母类型	Nut mass 螺母重量 g	D	Dr	L	L1	F	W	DP	Bolt Hole 安装孔 X	Cr N	Cor N	Ct Nm	Cot Nm	Nut mass 螺母重量 g		OD. 外径 DS				Length 长度 LS	Pin hole 销孔	
BSSP 0602/06	6	2	(750)	(1200)	1	25	15	29	17	13	4	17	23	3.4	(860)	(1400)	(2.2)	(1.6)	(3.0)	14	12	27	1.5	1.2	2	9.99 × 10 ⁻¹⁰	BSSP 0602/06
BSSP 0606/06		6	(870)	(1450)	2	20	14	27	17	8	4	16	21	3.4													BSSP 0606/06
BSSP 0610/06		10	(950)	(1600)	2	20	14	27	23	11.5	4	16	21	3.4													BSSP 0610/06
BSSP 0802/08 (1)	8	2	(850)	(1600)	1	25	16	30	17	13	4	18	24	3.4	(1200)	(1900)	(4.1)	(3.1)	(4.1)	22	15	30	2.0	1.5	3	31.6 × 10 ⁻¹⁰	BSSP 0802/08 (1)
BSSP 0802/08 (2)		2	(2400)	(4000)	1	60	20	38	24	19	5	22	30	4.5													BSSP 0802/08 (2)
BSSP 0802/08 (3)		2	(1300)	(2300)	3	25	15	28	18	14	4	17	22	3.4													BSSP 0802/08 (3)
BSSP 0804/08		4	(2600)	(4200)	1	75	21	39	28	23	5	23	31	4.5													BSSP 0804/08
BSSP 0812/08		12	(2200)	(4000)	2	40	18	31	27	17	4	20	25	3.4													BSSP 0812/08

- 注1) 中空孔为选配件。根据丝杠轴的长度，也可能不适用。
- 注2) 需要特殊的螺母形状时，请垂询本公司。
- 注3) 基本额定负载、基本额定扭矩、许用扭矩是根据有效负载滚珠数量计算出的理论值。根据不同的使用条件会发生很大变化，请仅作参考。
- 注4) 本产品是承受径向负载的滚珠花键和承受轴向负载的滚珠丝杠的组合产品，很难预估其理论寿命。建议使用实机进行评估，或根据本公司的实验数据来判断是否适用。
- 注5) 可生产的最大长度为max.150mm (f6)、max.200mm (f8)。需要超过上述长度的产品时，请垂询本公司。

- Note 1) Please note that Bore hollow is an option, not a standard. In some cases Bore hollow is not available due to Shaft length.
- Note 2) If special profile of Ball Screw Nut / Ball Spline Nut, please ask KSS representative.
- Note 3) Basic Load Rating, Basic Torque Rating and Permissible Moment are theoretical number based on effective number of Balls. They may vary drastically depending on operating condition. Please consider them just reference.
- Note 4) It is difficult to estimate theoretical life, because of combined products with Ball Spline which withstands Radial Load and Ball Screw for Axial Load. We would recommend that final decision should be based on your evaluation on actual machine or our experimental data.
- Note 5) Maximum limit of Shaft length is 150mm (for f6), 200mm (for f8). Please ask KSS in case of exceeding limit length.