

2-phase Stepping Motor (Bi-polar 0.7A / phase & □25) with Resin Lead Screw type Actuator

附带2相 步进电机(双极 0.7A / 相 □25)的树脂螺母滑动丝杠型执行器

Motor Model / 电机型号 : 10PM-K202B (Single shaft / 单轴)
 Minebea Motor / 美蓓亚电机
 推荐驱动 / Driver recommendation : SD4030B

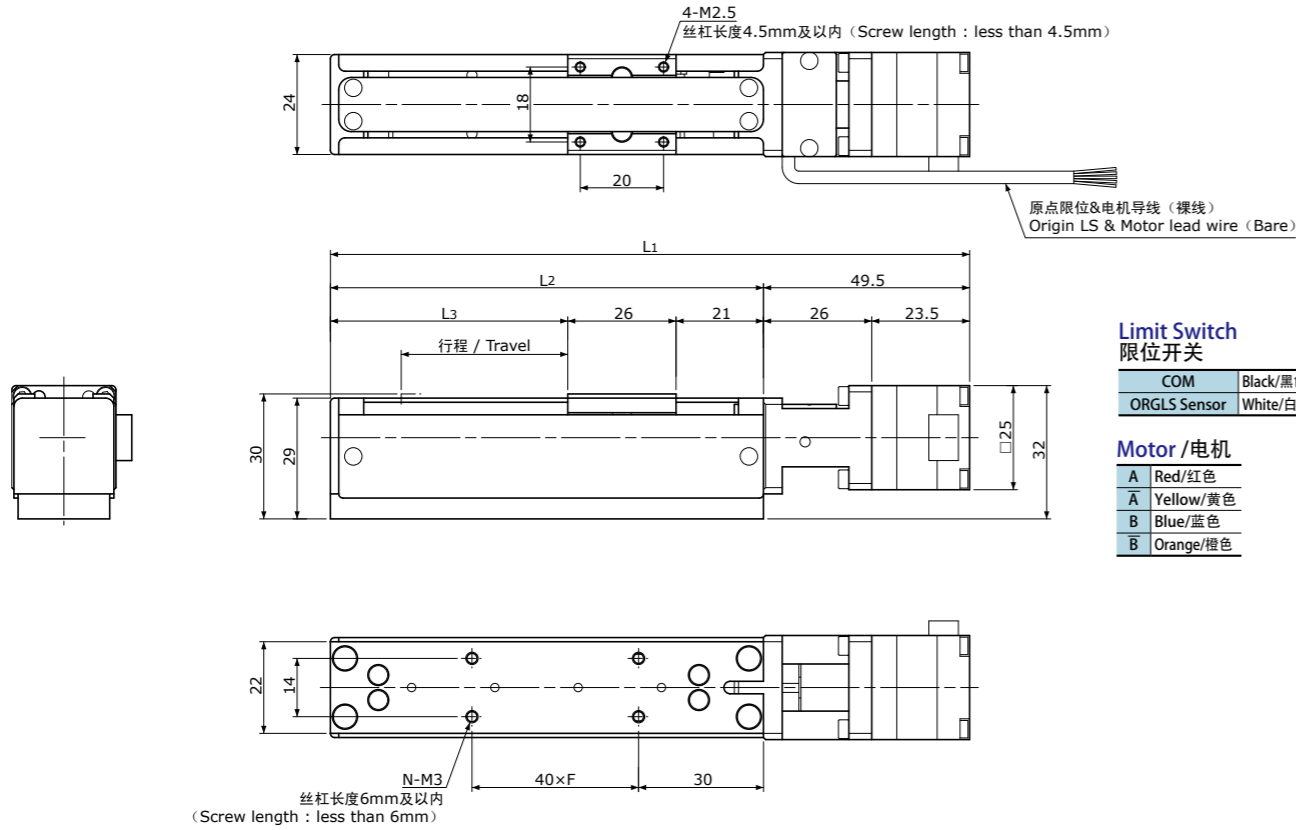

Limit Switch 限位开关

COM	Black/黑色
ORGLS Sensor	White/白色

Motor / 电机

A	Red/红色
A̅	Yellow/黄色
B	Blue/蓝色
B̅	Orange/橙色

连接器选择方案
 请从下面指定连接器类型。
 没有指示的采用裸线。

- 裸线
- 广濑RP17-13J-12SC
- EI连接器 (Tyco Electronics制造)
 6芯 (172211-6、电机)+4芯 (172211-4、传感器)

Connector choice
 Please designate connector type below.
 No connector if there is no designation.

- None (Bare)
- RP17-13J-12SC (HIROSE)
- EI-Connector (Tyco Electronics)
 (172211-6 pins for Motor +
 172211-4 pins for Sensor)

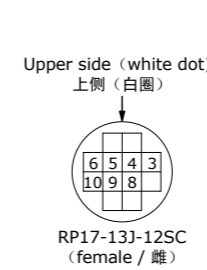

HIROSE RP17 Connector 广濑RP17连接器规格

1	None 无
2	None 无
3	Stepping Motor A (Red/红色)
4	Stepping Motor A (Yellow/黄色)
5	Stepping Motor B (Blue/蓝色)
6	Stepping Motor B (Orange/橙色)
7	None 无
8	COM (Black/黑色)
9	Short circuit with No.8 与8号短路
10	ORGLS Sensor/传感器 NC (White/白色)
11	None 无
12	None 无

EI Connector EI连接器规格

1	None 无
2	None 无
3	Stepping Motor A (Red/红色)
4	Stepping Motor A (Yellow/黄色)
5	Stepping Motor B (Blue/蓝色)
6	Stepping Motor B (Orange/橙色)

注释

- 1) 加减速率为推荐值。
- 2) 使用时不得出现结露现象。
- 3) 容许力矩是其它方向没有负荷时的值。
- 4) 分解度为整步时的值。
- 5) 导线为裸线及右出时的型号。
- 6) 低速时, 原点恢复的过程中的振动可能会有些偏大。

Note

- 1) Acceleration & deceleration rate is our recommendation.
- 2) There should be no condensation when using.
- 3) Permissible Moment is the number when no load in other direction.
- 4) Resolution represents the values for full step.
- 5) Model number is for no-connector and lead wire is set on right side on Motor.
- 6) Vibration may increase at low speed or zero return.

Model Number 执行器型号	Travel 行程 (mm)	Screw Lead 丝杠导程 (mm)	Resolution 分解度 (μm)	Length 长度尺寸 (mm)					Max. Load Capacity 最大可搬负载 (N)		Permissible speed 容许速度 (mm / sec)	Mass 质量 (g)
				L ₁	L ₂	L ₃	F	N	Hor. 水平	Vert. 垂直		
FAS-Re020-040MNR	40	2	10	153.5	104	57	1	4	9.8	2.94	6~20	205
FAS-Re060-040MNR		6	30									
FAS-Re090-040MNR		9	45									
FAS-Re020-080MNR	80	2	10	193.5	144	97	2	6	9.8	2.94	6~20	250
FAS-Re060-080MNR		6	30									
FAS-Re090-080MNR		9	45									
FAS-Re060-120MNR	120	6	30	233.5	184	137	3	8	9.8	2.94	18~60	290
FAS-Re090-120MNR		9	45									
FAS-Re060-160MNR	160	6	30	273.5	224	177	4	10	9.8	2.94	18~60	335
FAS-Re090-160MNR		9	45									
FAS-Re060-200MNR	200	6	30	313.5	264	217	5	12	9.8	2.94	18~60	375
FAS-Re090-200MNR		9	45									

注1) 树脂螺母滑动丝杠型的润滑规定是滑动丝杠部为Sumitec Liquid H20, 导杆部为油脂MSG No.2。
 注2) 有关与推荐的驱动器 (SD4030B) 的接线, 请参照第G133页。
 Note 1) In case of Resin Lead Screw type, Lubrication is Sumitec Liquid H20 on Resin Lead Screw, Grease MSG No.2 on Guide.
 Note 2) Refer to page G133 for connection diagram of recommended Driver (SD4030B).

Common Specifications 通用规格	
Repeatability 重复定位精度	Max. ±0.05mm
Lost Motion 空转	Max. 0.05mm
Body Material 本体材质	Aluminum 铝
Sliding guide 导向结构	Slide Guide rail 滑动导轨 (1列)
Sensor 传感器	Limit switch 限位开关
Accuracy of Zero pt. return 原点恢复精度	Max. ±0.05mm
Acceleration & Deceleration Rate 加减速率	Min. 100ms / kHz 100ms / kHz 及以上
Permissible Moment 容许力矩	
Pitching 俯仰 Mp	0.10Nm
Yawing 偏转 My	0.09Nm
Rolling 滚压 Mr	0.23Nm
Lubrication 润滑	See Note 参照注释
Operating Temp. 使用温度范围	0~40° C

Miniature Actuator
微型执行器篇

Miniature Actuator
微型执行器篇