

公称型号的构成 / Model number notation

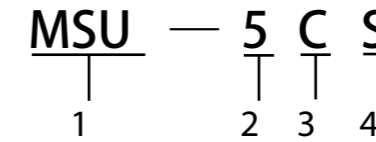

- 1 系列符号
MSU : KSS紧凑型支架组件系列
- 2 公称型号
- 3 形状符号
C : 枕型
G : 法兰型
- 4 轴端符号
无符号 : 固定侧
S : 支撑侧

- 1 Series No.
MSU : KSS Compact Support Unit Series
- 2 Nominal number
- 3 Housing type
C : Pillow type
G : Flange type
- 4 End-journal type
None : fixed side
S : supported side

注) 支撑侧支架组件的公称型号可能与轴承内径不一致, 敬请注意。
Note) In some cases, nominal number is not the same as Bearing Inner diameter.

Parts List / 零件表

Part No. 零件号	Part name 零件名称	Qty 数量
1	Housing / 外壳 (Black Chrome coating / 黑铬处理)	1
2	Bearings / 轴承 (with Shields / 带护板)	1 set
3	Pressure Nut / 压紧螺母	1
4	Collar / 轴环	1
5	Lock Nut / 锁紧螺母	1
6	Hexagonal socket head set screw / 内六角止动螺丝 (with set piece / 带定位块)	1 set

Unit (单位) : mm

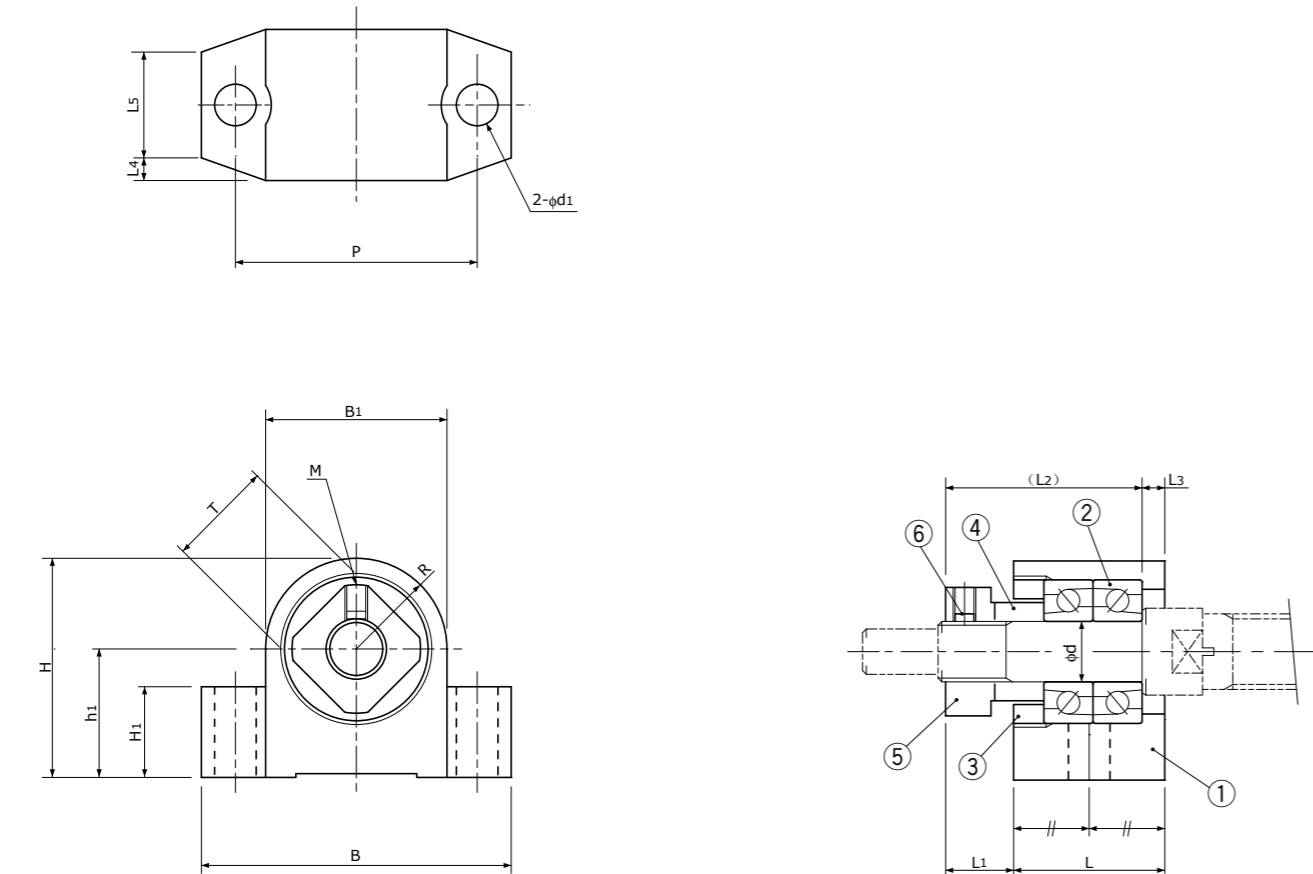

Type 型号	Brg. Inner dia. 轴承内径 d 0 -0.005	L	L ₁	L ₂	L ₃	L ₄	L ₅	B	H	h ₁ 0 -0.03	B ₁	H ₁	R	P	d ₁	M	T	Lock Nut 锁紧螺母	Tightening torque of Lock Nut 锁紧螺母的紧固扭矩 N·cm	Bearing 使用的轴承	Mass 重量 g	Type 型号
MSU-3C	3	12.5	5.5	16.5	1.5	2	8.5	24	14.5	9	11	5	5.5	18	3.5	M3	8	M3×0.5	80	MTA03-08HP5DF	16.5	MSU-3C
MSU-4C	4	14	5.5	17.5	2	2.5	9	27	17	10	14	6	7	21	3.5	M3	10	M4×0.5	100	MTA04-11HP5DF	27	MSU-4C
MSU-5C	5	15	5.5	18.5	2	2	11	30.5	19.5	11	17	6	8.5	23	4.5	M3	11	M5×0.5	140	MTA05-13HP5DF	35	MSU-5C
MSU-6C	6	17	7.5	22	2.5	2.5	12	35	22.5	13	19	8	9.5	26	5.5	M3	12	M6×0.75	190	MTA06-15HP5DF	50	MSU-6C
MSU-8C	8	20	9	26	3	3	14	41	29	17	24	12	12	32	5.5	M3	14	M8×1.0	200	MTA08-19HP5DF	96	MSU-8C

注1) 角接触球轴承 (ISC制) 采用不锈钢材质, 并注入有低起尘润滑脂 (NSK LG2), 是无尘规格的轴承。

注2) 压紧螺母、轴环、锁紧螺母均经过了发黑处理。

注3) 支架组件已经过预压调整, 请勿进行拆分。

Note 1) Angular Contact Ball Bearings (manufactured by ISC) are designed for clean room use, they are made of Stainless steel with low contamination grease (NSK LG2) packed.

Note 2) Pressure Nut, Collar and Lock Nut are coated with Black finishing.

Note 3) Do not disassemble Support Unit, as they are pre-loaded and pre-adjusted.