

SR0401

Shaft dia. (軸径) $\phi 4$ Lead (リード) 1mm

Ct7&Ct10

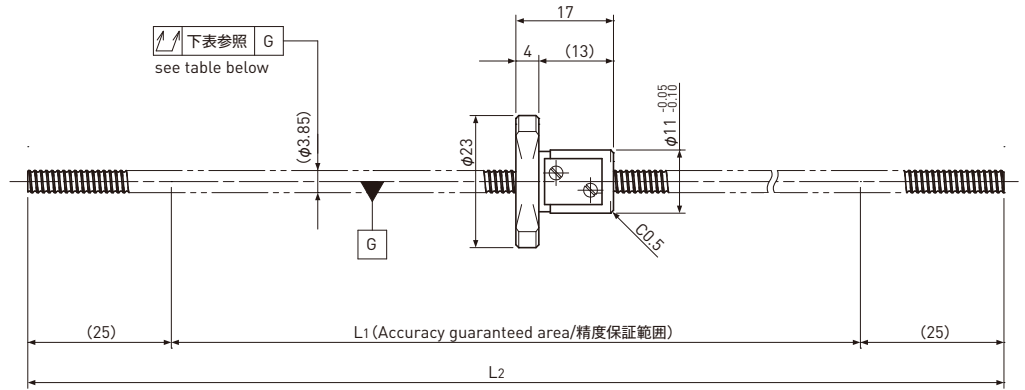
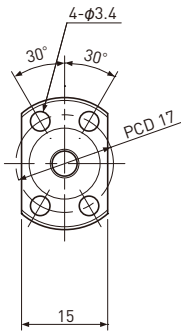

Unit (単位) : mm

| Ball Screw Specifications 諸元 | |
|------------------------------|------------------------|
| Ball size ボール径 | $\phi 0.8$ |
| Number of thread 条数 | 1 |
| Thread direction 巻方向 | Right 右 |
| Shaft root dia. ねじ軸谷径 | $\phi 3.3$ |
| Number of circuit 循環数 | 3.7×1 |
| Shaft, Nut material 軸、ナット材質 | SCM415H |
| Surface hardness ねじ部表面硬度 | HRC58~62 (Thread area) |
| Anti-rust treatment 防錆処理 | Anti-rust oil 防錆油 |

Unit (単位) : mm

| Ball Screw Model ボールねじ型番 | Travel ストローク | Grade 精度 | Shaft length ねじ軸長さ | | Lead accuracy リード精度 | | Total Run-out 全振れ \nearrow | Axial play 軸方向すきま | Preload Torque 予圧トルク Nm | Basic Load Rating 基本定格荷重 N | |
|-----------------------------|-----------------|-------------|-----------------------|----------------|--------------------------------------|------------------------------|------------------------------------|----------------------|-------------------------------|-------------------------------|------------------------|
| | | | L ₁ | L ₂ | Travel deviation 代表移動量誤差 e_p | Variation 変動 V_{300} | | | | Dynamic 動定格荷重 Ca | Static 静定格荷重 Coa |
| SR0401-250R250C7 | 180 | Ct7 | 200 | 250 | ± 0.06 | 0.05 | 0.200 | ~ 0.020 | — | 560 | 790 |
| SR0401-250R250C10 | 180 | Ct10 | 200 | 250 | ± 0.28 | 0.21 | 0.400 | ~ 0.050 | | | |

Note) Please designate end-journal profile with your sketch. 注)軸端の追加工は図面とともにご指示ください。