

Single axis Actuator

Flex Actuator Series

Actuator
fLEX

Many variation of KSS Flex Actuator became reality. Various choices among accuracy(Drive Screw type), speed(Screw Lead), Travel length and power(Motor type) are available.



Features

- We make full use of features of Miniature Ball Screw manufacturer and super compact design Actuator can be achieved.
- Depending on kinds of Drive Screws, wide range of choices related to positioning accuracy are available.
- Several variations of Screw Lead & Travel for each Screw type are standardized. So wide variety of choice for speed is available.
- Motor-less type is our standard, but a couple of Motors are in stock as an option. Suitable Motor and Actuator would be assembled in accordance with your specifications.
- Recommended Motor Drivers for each Motors are also in stock.
- Accessories can be provided as special design, such as outside photo-sensor, Brake unit and so on.

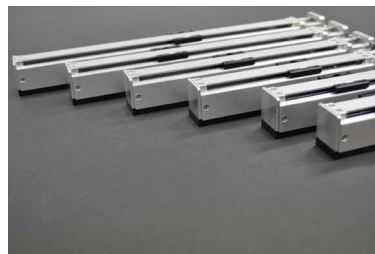

Wide range of choices

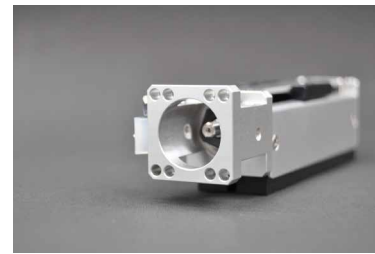

Motor-less is standard



Wide variety of Drive Screw type

Structure

KSS Flex Actuator is the slider type Actuator, which is built in small size Drive Screw and Slide Guide in it. KSS Flex Actuator series are standardized without Motor. It is designed to set the appropriate Motor easily based on the required specifications.

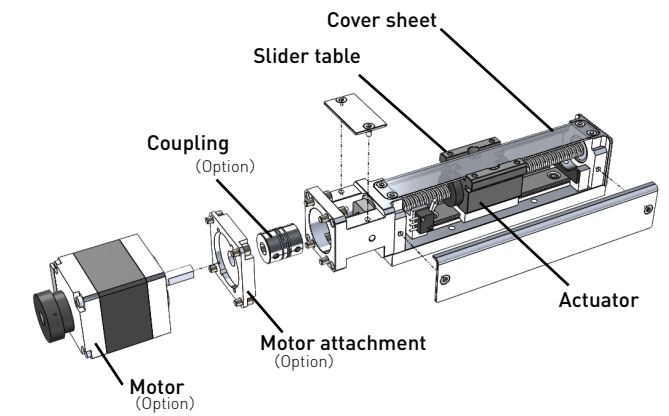

Variation & Features

There are several kinds of KSS Flex Actuators shown below. Each Actuator has a different kinds of Drive Screw inside. Please choose appropriate type Drive Screw depending on your required accuracy. For further information, please refer to Table Q-3 in page Q106.

1) Rolled Ball Screw type

Reasonable price and accuracy have been achieved by using Rolled Ball Screw.

2) Precision Ball Screw type

High accuracy in both Repeatability and Lost motion by using Precision Ball Screw.

3) Resin Lead Screw type is available for less-expensive application based on your request. Please ask KSS representative.

Table Q-1 : Positioning accuracy for each Drive Screw

Drive Screw type	Repeatability (mm)	Lost motion (mm)
Rolled Ball Screw	±0.01 max.	0.01 max.
Precision Ball Screw	±0.005 max.	0.005 max.

Note) These numbers are obtained with standard Motor.

There are several choices of Motor as option shown below. Specifications for each combination of Actuator and Motor are shown in page Q106.

Motor type	Manufacturer	Model number	Rated Current
2-phase □25	Minebea Motor	10PM-K202B Single shaft	0.7A / Phase
5-phase □28	Oriental Motor	PK523HPB Double shaft	0.75A / Phase

● Model number notation

FA **S** **-** **G** **020** **-** **080** **M** **N** **R** **SBU**
 ① ② ③ ④ ⑤ ⑥ ⑦ ⑧ ⑨

- ①Series No.
FA : KSS Flex Actuator Series
- ②Actuator type
S : Slider type
- ③Drive Screw type
R : Rolled Ball Screw
G : Precision Ball Screw
- ④Lead / Pitch (mm) : 020 means 2mm
- ⑤Travel (mm) : 080 means 80mm
- ⑥Motor type
None : No Motor (Standard)
M : Minebea Motor 2-phase Stepping Motor (□25&0.7A / phase)
E : Oriental Motor 5-phase Stepping Motor (□28&0.75A / phase)
S : Other
- ⑦Connector type
N : No connector (Bare)
H : HIROSE RP17
E : EI connector (TE Connectivity)
- ⑧Direction of Motor leads
R : Right (from Shaft end side)
L : Left
- ⑨Option
None : no optional design
S : Photo micro Sensor outside
B : Solenoid Brake Unit
U : Side Motor mounting kit

● Combination & Specifications

KSS Flex Actuator has a lot of combinations with Drive Screws (positioning accuracy), Screw Lead, and travel length. Motor-less type is our standard, but 2 types of Motor can be provided as an optional order. Standard combination and Motor choices make design flexibility enlarge widely based on your specifications. Combination of Drive Screw and Motor are shown in Table Q-2. The detail specifications and dimensions are described in each dimension table. If other combination in Table Q-2 is required, please ask KSS representative.

Standard Combination

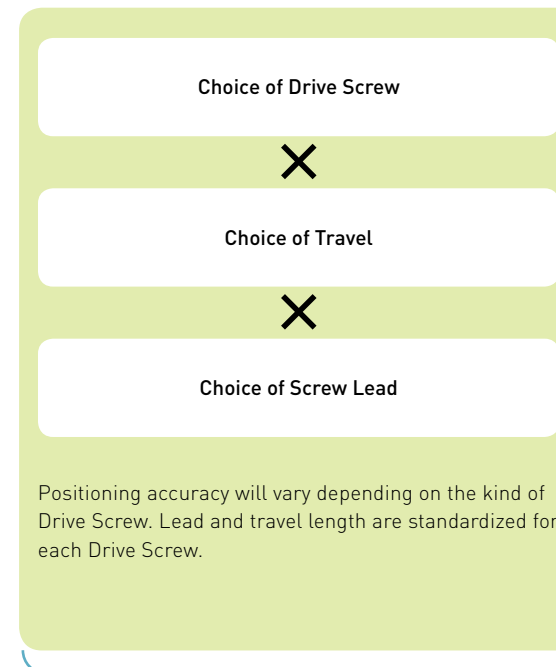

Motor Option

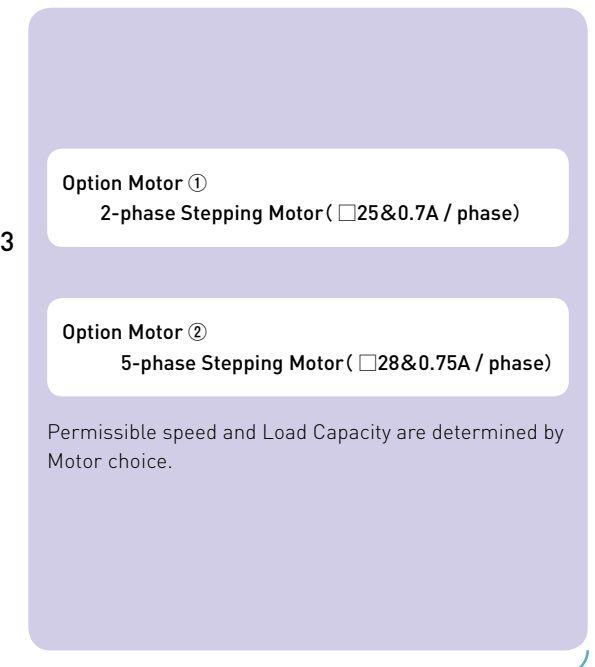

Refer to Table Q-3

The detail specifications for each combination are shown in dimension Table. Page index is shown in Table below.

Table Q-2 : Page index for each combination

Motor		Rolled Ball Screw	Precision Ball Screw
Standard	Motor : None	See page Q107~Q108	See page Q109~Q110
Option	M Minebea Motor 2-phase Stepping Motor(□25&0.7A / phase) Bi-polar type	See page Q111~Q112	See page Q113~Q114
	E Oriental Motor 5-phase Stepping Motor(□28&0.75A / phase)	See page Q115~Q116	See page Q117~Q118

● Selection guide

KSS Flex Actuator has a lot of combinations with Drive screws, Screw Lead, Travel length and Motor as an option. Therefore, when you try to select the suitable combination, its procedure may be complicated. KSS shows the selection guide below from the various approach of choices.

Drive Screw selection guide	Positioning related accuracy	Price
Rolled Ball Screws	Middle	Reasonable
Precision Ball Screws	High	Costly

Screw Lead selection guide	Speed	Resolution	Load Capacity
1mm	Slow	High	High
2mm	↕	↕	↕
6mm			
10mm	Fast	Low	Low

Motor selection guide	Fine step	Acceleration	Rotational speed	Price
2-phase □25	Middle	Middle	Middle	Less expensive
5-phase □28	Fine	High	Low & high speed	Costly

The table above shows the functional comments when the Motor is built in KSS Flex Actuators. Please note that the table above is not the function of Motor itself. For more detail, please see the table of specifications in next page.

Table Q-3 : Specifications for each combination

Drive Screw type	Rolled Ball Screw	Precision Ball Screw
Repeatability(mm)	±0.01 max.	±0.005 max.
Lost motion(mm)	0.01 max.	0.005 max.
Permissible Moment(Nm) Mp(Pitching)	0.10 ** In case of no load in My & Mr direction	
Permissible Moment(Nm) My(Yawing)	0.09 ** In case of no load in Mp & Mr direction	
Permissible Moment(Nm) Mr(Rolling)	0.23 ** In case of no load in Mp & My direction	

Spec. for each Motor		Rolled Ball Screw				Precision Ball Screw				
Motor	Lead(mm)	1	2	6	10	1	2	6	10	
	H:Horizontal V:Vertical									
Standard	Max. Load Capacity(N)	H	29.4	29.4	19.6	19.6	29.4	29.4	19.6	19.6
		V	19.6	19.6	9.8	4.9	19.6	19.6	9.8	4.9
Motor-less	Permissible speed(mm / sec)	0~25	0~50	0~150	0~250	0~25	0~50	0~150	0~250	
Motor : M 2-phase / 2相 □25 0.7A / phase	Max. Load Capacity(N)	H	29.4	29.4	19.6	19.6	29.4	29.4	19.6	19.6
		V	19.6	19.6	2.94	2.94	19.6	19.6	2.94	2.94
	Permissible speed(mm / sec)	3~20	6~40	18~120	30~200	3~20	6~40	18~120	30~200	
Motor : E 5-phase □28 0.75A / phase	Max. Load Capacity(N)	H	29.4	29.4	19.6	19.6	29.4	29.4	19.6	19.6
		V	19.6	19.6	4.9	4.9	19.6	19.6	4.9	4.9
	Permissible speed(mm / sec)	0~25	0~50	0~150	0~250	0~25	0~50	0~150	0~250	
**Motor mounting is option	Travel(mm)	20	○				○			
		40	○	○	○	○	○	○	○	○
		80	○	○	○	○	○	○	○	○
		120			○	○			○	○
		160			○	○			○	○
200			○	○			○	○		

Note 1) In case of Standard (Motor-less), Repeatability & Lost motion are reference value, Permissible speed & Load Capacity are recommended value.

Note 2) For more detail, please refer to dimension table.

Compact Actuator NEMA 6 size

CAS Series

The most compact single axis Actuator in KSS with NEMA 6 size of 2 phase stepping Motor.

Features

Realized compactness not only the body width, but total length of the Actuator by combining NEMA 6 Stepping Motor using our unique coupling - less connection.



Specifications

	Lead 1mm	Lead 2mm
Travel (mm)	20, 40	
Drive Screw	Rolled Ball Screw	
Resolution (mm)	0.005	0.01
Repeatability (mm)	Max. ± 0.010	
Lost motion (mm)	Max. 0.010	
Horizontal Load Capacity (N)	Max. 10	Max. 5
Vertical Load Capacity (N)	Max. 5	Max. 3
Permissible speed (mm/sec)	Max. 20	Max. 40
Maximum acceleration (m/sec ²)	0.1	0.2
Permissible Moment Mp (Nm) (Pitching)	0.14	
Permissible Moment My (Nm) (Yawing)	0.12	
Permissible Moment Mr (Nm) (Rolling)	0.22	

Recommended Drivers	SD4015B3
---------------------	----------

Note) Refer to page Q130 for connection diagram of recommended Drivers.

Structure

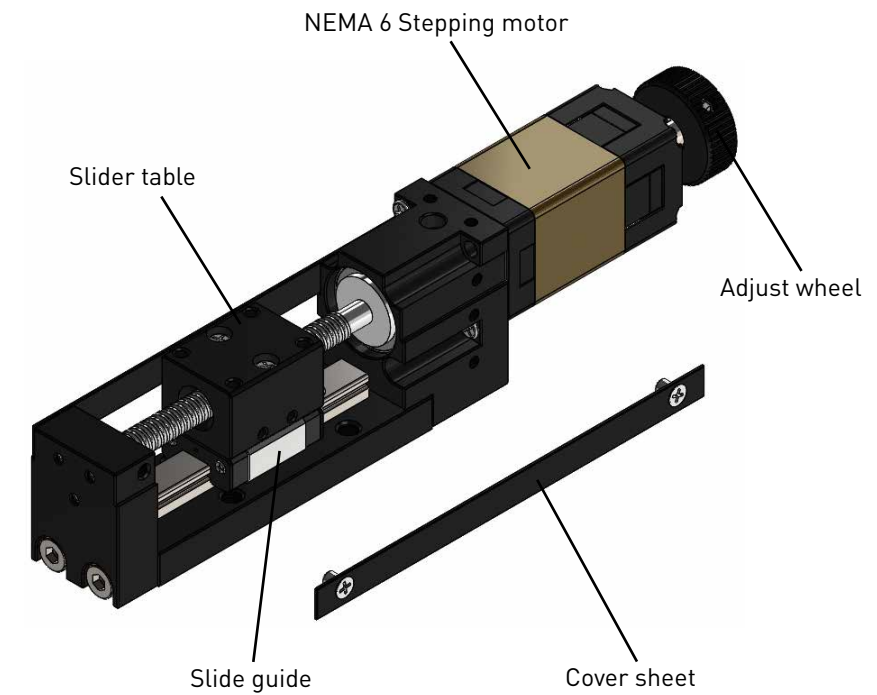

Model number notation

CAS 14 - R 010 - 020 H R S

① ② ③ ④ ⑤ ⑥ ⑦ ⑧

- ① Series No.
CA : KSS Compact Actuator Series
- ② Motor Frame Size
14 : NEMA 6
- ③ Drive Screw type
R : Rolled Ball Screw
- ④ Lead / Pitch (mm) : 010 means 1mm
- ⑤ Travel (mm) 020 means 20mm
- ⑥ Connector type
N : No connector (Bare)
H : HIROSE RP17
E : EI connector (TE Connectivity)
S : Others
- ⑦ Direction of Motor leads
R : Right (from shaft end side)
L : Left
T : Top
B : Bottom
- ⑧ Option
S : Sensor outside

MoBo Actuator (MA Series)

MoBo Actuator

External Ball Screw type(MoBo) is built in this series, what we call MoBo Actuators. All of MoBo Actuators are produced as customized products, in accordance with customer's order.



●Features

More compact design of Unit products in longitudinal dimension became reality by using Direct Motor Drive Ball Screws / Resin Lead Screws.

●Variation

There are several kinds of MoBo Actuator shown below. Each Actuator has a different kinds of Ball Screw / Lead Screw inside.

1) Precision Ball Screw type

High accuracy in both Repeatability and Lost motion by using Precision Ball Screw.

2) Rolled Ball Screw type

Reasonable price and accuracy have been achieved by using Rolled Ball Screw.

3) Resin Lead Screw type

It can be used without oiling in normal environment, because lubricating agent is incorporated in Resin Nut.

●Model number notation

MA S - G 020 - 015 N R

① ② ③ ④ ⑤ ⑥ ⑦

①Series No.

MA : MoBo Actuator Series

②Actuator type

S : Slider type

③Lead Screw / Ball Screw

G : Precision Ball Screw

R : Rolled Ball Screw

Re : Resin Lead Screw

④Lead/Pitch (mm): 020 means 2mm

⑤Travel (mm): 015 means 15mm

⑥Connector type

N : No connector (Bare)

H : HIROSE RP17

E : EI connector (TE Connectivity)

⑦Direction of Motor leads

R : Right (from Shaft end side)

L : Left

●Structure

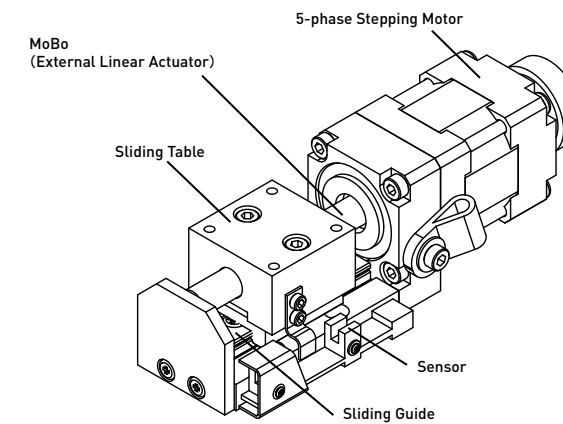

●Specifications

Overall specifications for MoBo Actuators are shown in Table below. For further information, please see dimension Table.

Model	MAS-G010-015	MAS-G010-030	MAS-R010-015	MAS-R010-030	MAS-Re020-015	MAS-Re020-030
Travel	15mm	30mm	15mm	30mm	15mm	30mm
Drive Screw	Precision Ball Screw Lead = 1mm		Rolled Ball Screw Lead = 1mm		Resin Lead Screw Lead = 2mm	
Sliding Guide	Slide Guide rail					
Body Material	Aluminum					
Mass	200g	210g	200g	210g	200g	210g
Resolution	0.002mm		0.002mm		0.004mm	
Repeatability	Max. ±0.005mm		Max. ±0.01mm		Max. ±0.05mm	
Lost motion	Max. 0.005mm		Max. 0.01mm		Max. 0.05mm	
Horizontal Load Capacity	Max. 29.4N		Max. 29.4N		Max. 9.8N	
Vertical Load Capacity	Max. 19.6N		Max. 19.6N		Max. 4.9N	
Permissible speed	0.4~20mm/sec		0.4~20mm/sec		0.8~15mm/sec	
Maximum acceleration	0.1m/sec ²					
Permissible Moment Mp (Pitching)	0.16Nm	** In case of no load in My & Mr direction				
Permissible Moment My (Yawing)	0.10Nm	** In case of no load in Mp & Mr direction				
Permissible Moment Mr (Rolling)	0.20Nm	** In case of no load in Mp & My direction				
Operating Temp.	0~40°C (without any due condensation)					
Lubrication	Ball Screw : KSS MSG No.2 Sliding Guide : KSS MSG No.2				Lead Screw: Sumitec Liquid H20 Sliding Guide: KSS MSG No.2	

●Motor : 5-phase Stepping Motor □24(NEMA 10) , 0.75A/phase

●Photo Micro sensor : EE-SX1103(Omron) , DC5V 50mA (Motor side and Travel end)

Options for Single axis Actuator

[Solenoid Brake Unit] (Only for Flex series)

If Flex Actuators are operated in vertical position, Ball Screw / Lead Screw may fall down when its power is off. Solenoid Brake Unit is effective to maintain intermediate position.

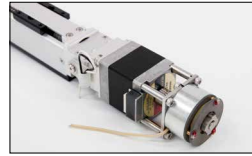

[Motor side mounting kit] (Only for Flex series)

This kit can shorten the Actuator length with side mounting Motor shown in Photo right. Motor mount, timing pulley, timing belt and set screws are included in this kit. KSS can assemble in accordance with your request.

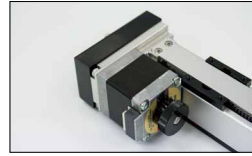

[Photo-micro sensor] (Only for Flex series)

Sensor accessories for the purpose of putting sensor outside Actuator. Sensor dog, sensor rail, photo sensor, sensor plate and set screws are included in this kit. KSS can assemble in accordance with your request.



[Grease]

KSS original Grease (MSG No.2) is used for KSS Flex Actuator series, except Lead Screw type. This Grease has high lubrication performance without deteriorating Ball Screw smooth movement. It would be useful for Grease maintenance to keep long term operation.



Recommended Driver

KSS provides Standard Stepping Motor Driver and Extension Cable as an option for Single axis Actuators in order to make it easy to use.

[Stepping Motor Driver]

KR-A5CC

This Driver is for 5-phase Stepping Motor operated by DC24V power supply. It has automatic current reduction circuits. You can choose full-step or half step function(page V102).



KR-A55MC

Micro-Step Driver for 5-phase Stepping Motor with DC24V power supply. 16 step angle types can be set with up to 250 divisions(page V103~V104).



SD4015B3

This is recommended 2-phase stepping Motor Driver for 0.25~1.5 A. It has Micro-Step function with 8-step angle(page V107).



SD4030B3

This is recommended 2-phase stepping Motor Driver for 0.5~3.0A. It has Micro-Step function with 8-step angle(page V108).



Extension Cable

Extension Cable between KSS Single axis Actuators and KSS recommended Stepping Motor Driver. Please designate Cable type, Cable length and Connector type in accordance with the example below. Please note that one side of Extension Cable is cut edge only (no connector).

EC **R** **—** **2** **—** **E(6)**
 ① ② ③ ④

- ① Extension Cable
- ② Cable type
R: Robot cable type
- ③ Cable length (m)
- ④ Connector type at both end
 - N : No connector (Bare)
 - H : HIROSE RP17
 - E(6) : EI connector 6-pins (for Motor only)
 - E(4) : EI connector 4-pins (for Sensor only)
 - E(6+4) : EI connector 6+4-pins (for Motor & Sensor)



H : HIROSE RP17

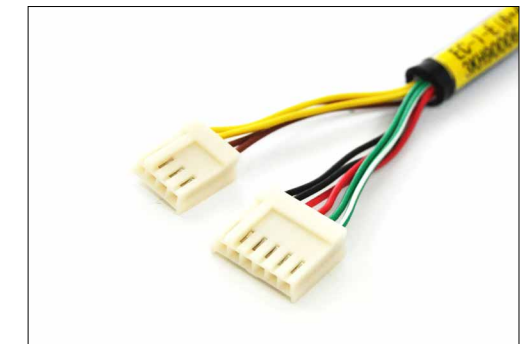

E(6+4) : EI connector 6+4-pins
(TE Connectivity)

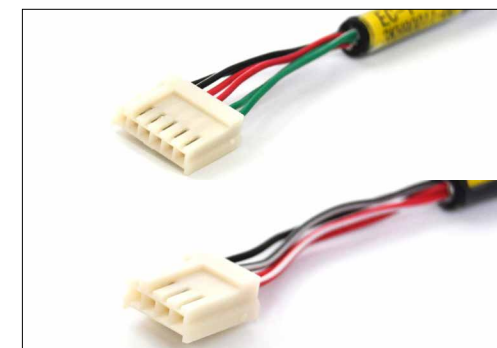

E(6) : EI connector 6-pins
E(4) : EI connector 4-pins
(TE Connectivity)

Connection diagrams

● For Flex series

[SD4030B3 Connection diagrams]

Applicable Motor
Minebea Moter 10PM-K202B



[Ei connector]

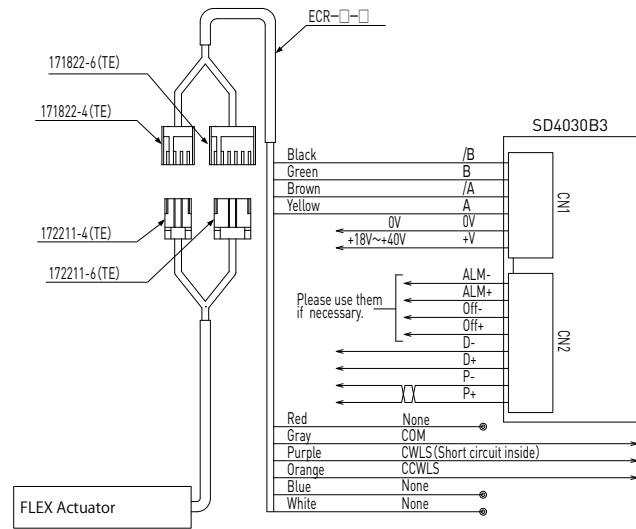

[HIROSE connector]

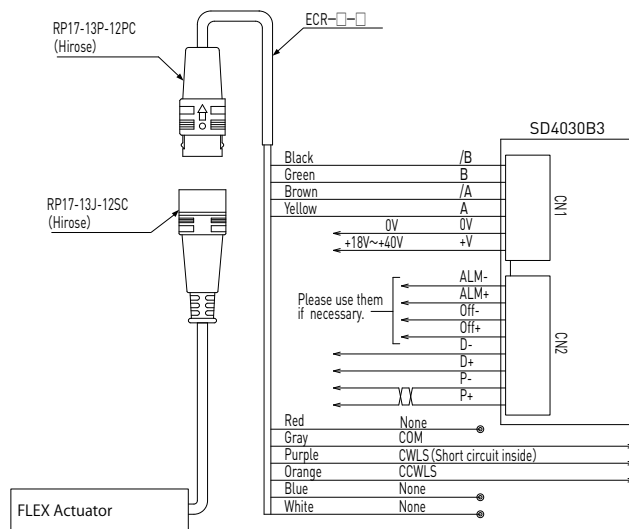

[KR-A55MC Connection diagrams]

Applicable Motor
Oriental Moter PK523HPB



[Ei connector]

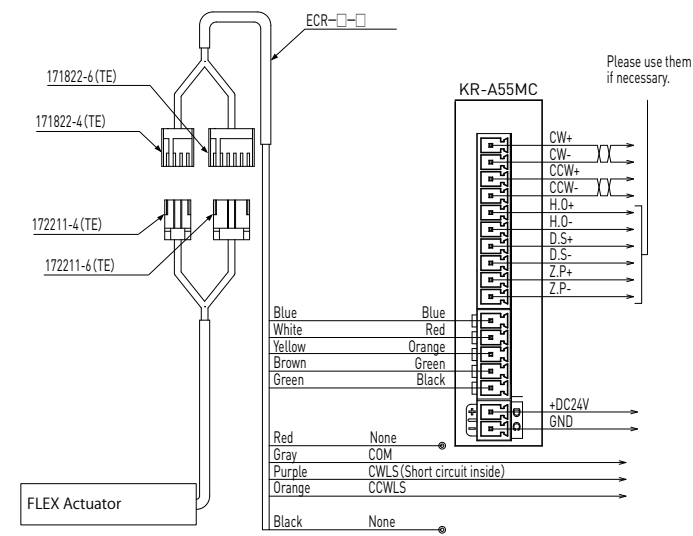

[HIROSE connector]

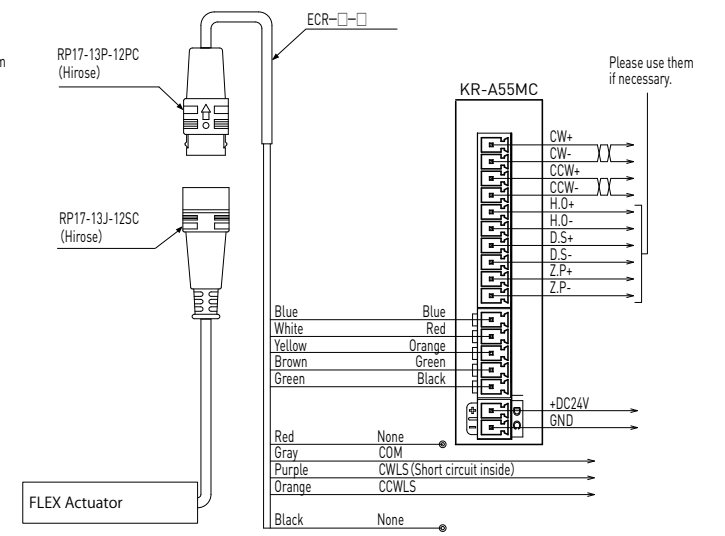

[KR-A5CC Connection diagrams]

Applicable Motor
Oriental Moter PK523HPB



[Ei connector]

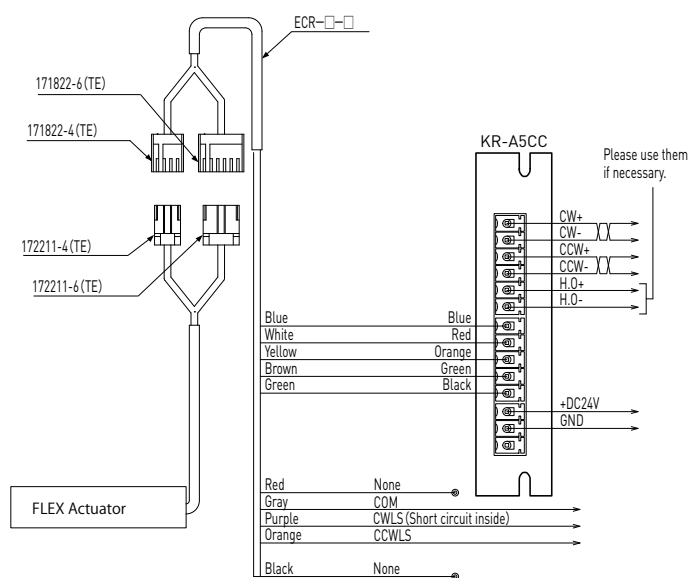

[HIROSE connector]

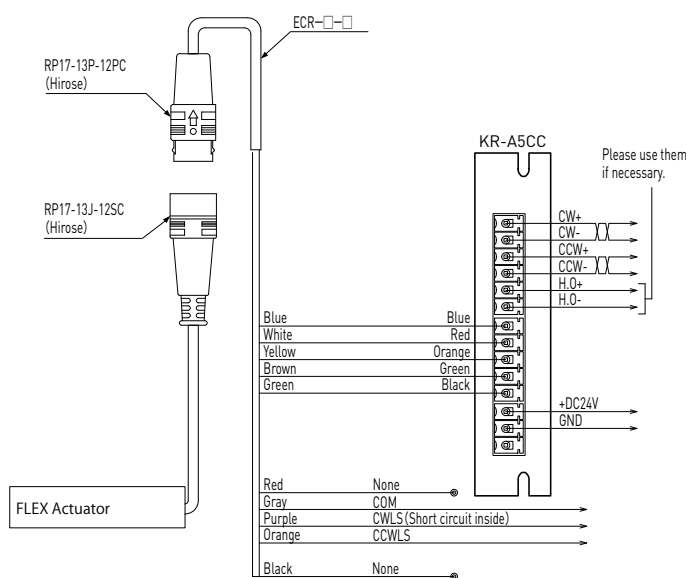

● For CAS series

[SD4015B3 Connection diagrams]

Applicable Motor
Sanyo SH2141-551



[Ei connector]

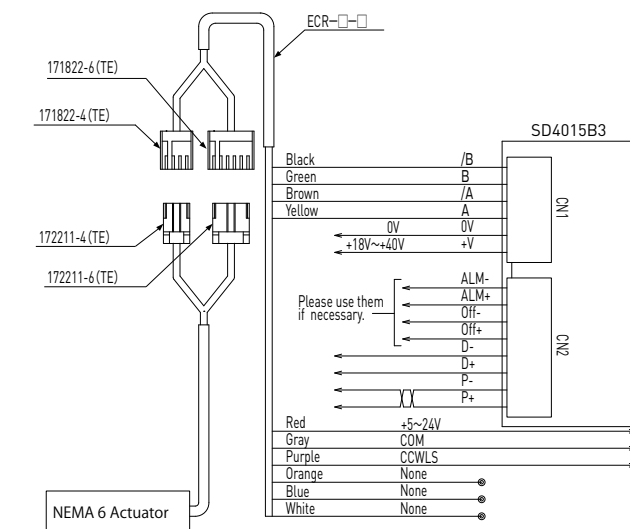

[HIROSE connector]

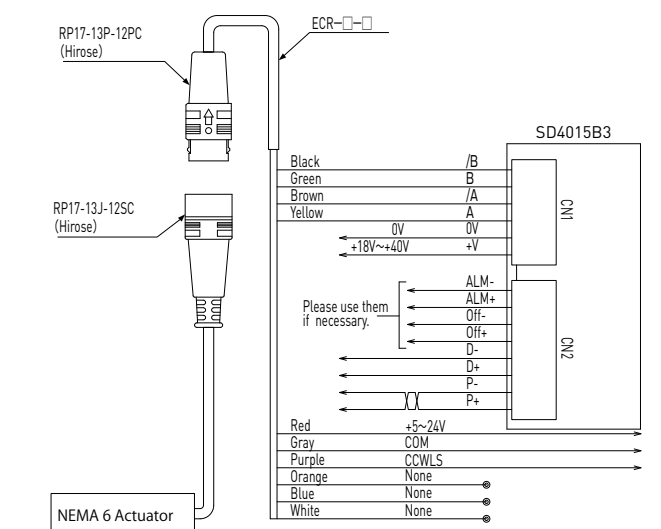

● For MA series

【KR-A5CC Connection diagrams】

Applicable Motor
TAMAGAWA SEIKI Dedicated Motor for Linear Actuator



【EI connector】

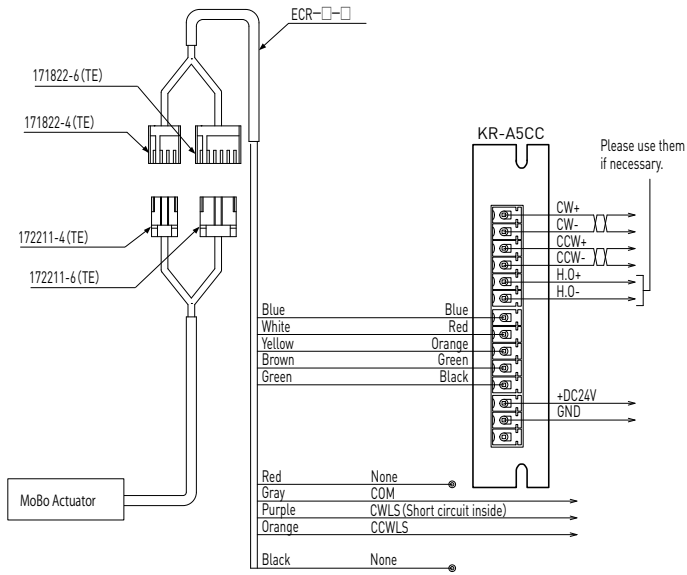

【HIROSE connector】

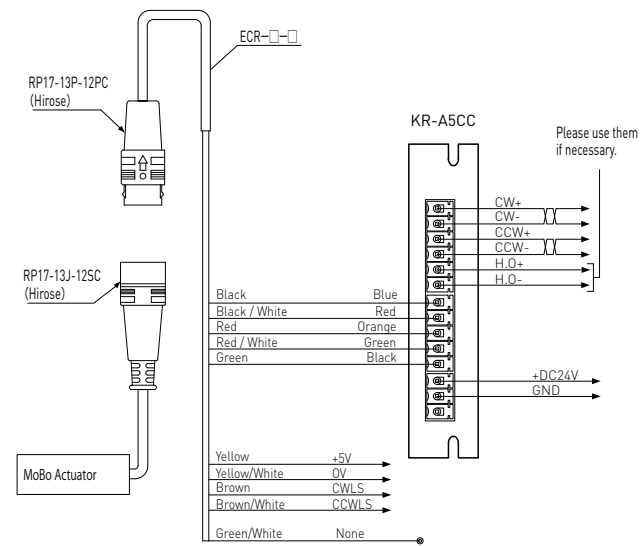

【KR-A55MC Connection diagrams】

Applicable Motor
TAMAGAWA SEIKI Dedicated Motor for Linear Actuator



【EI connector】

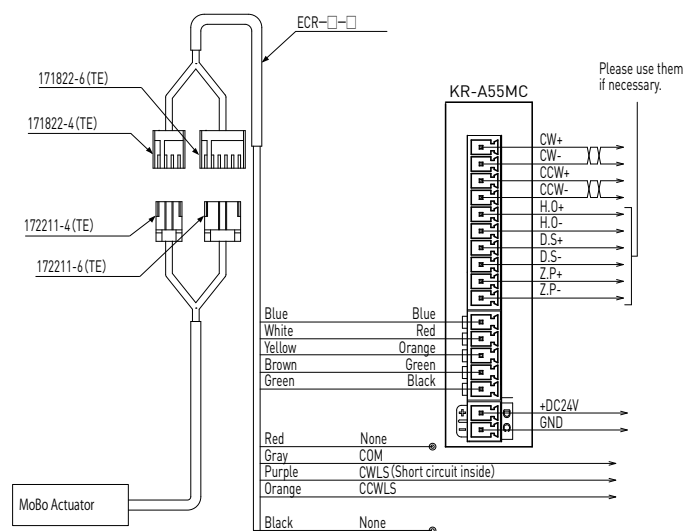

【HIROSE connector】

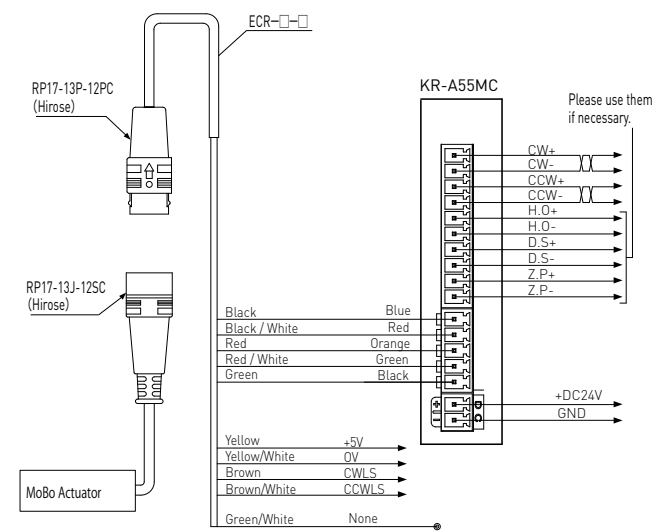

● Precaution of handling and operating

【Precaution for safety】

- 1) Before using these products, please read instruction manuals and follow the precautions below.
- 2) Do not hit or drop the Shaft, do not apply Axial or Radial load exceeding specifications, it may cause malfunction.
- 3) Before using, please check that the product has no defect, and product is the same as your order.
- 4) Do not disassemble each component, dust may get inside the product. It may deteriorate accuracy.
- 5) Please prevent contamination from dust or swarf. Dust or swarf may cause damage to Ball Screw/Lead Screw, which lead to deteriorating the function.
- 6) Single axis Actuator should be checked the lubricant condition every 2 to 3 months. If Grease is contaminated, remove old Grease and replace with new one. Grease should be the same as the original Grease, which is described in dimension table.
- 7) Do not use Single axis Actuator exceeding our specifications in Load or Speed.
- 8) Do not use Single axis Actuator beyond the Maximum Acceleration.
- 9) Do not hold the Motor leads and Sensor leads, this may result in damage to the device or injury. The Motor lead wire should be fixed securely.
- 10) Keep away from Magnetic memory device.

【Precaution for safety】

- 1) If abnormal odor, noise, smoke overheating, or vibration occurs, stop operation immediately and turn the power off.
- 2) Do not use exceeding rated current.
- 3) The Motor may overheat depending on the load conditions or driver used. Make sure that the Motor surface temperature does not exceed 80°C when in use.
- 4) Do not bend, pull or pinch the Motor lead wire.
- 5) Do not touch moving parts during operation.
- 6) Please switch off the Driver, when inspection or maintenance.

【Operating environment】

- 1) Operating environment should be 0~40°C in temperature and 20~80%RH in humidity. Do not use these products under dew condensation, corrosive gas or inflammable gas environment.
- 2) Do not use these products under strong electric field, strong magnetic field.
- 3) Please prevent from swarf, oil mist, cutting fluid, Water/moisture, salt spray, organic solvent and other contamination.
- 4) Single axis Actuator cannot be used under the vibration, impact, vacuum, and other special environment.