

SG0401

 Shaft dia.(轴径) $\phi 4$ Lead(导程) 1mm

C3&C5

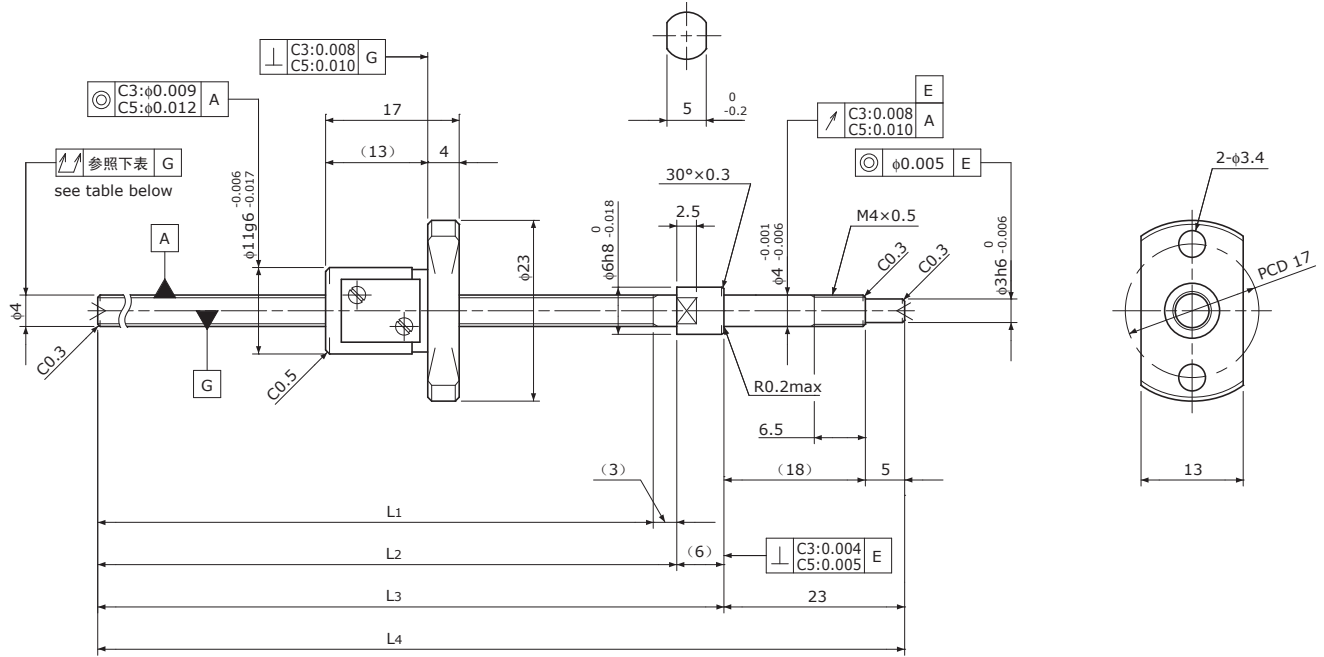

Unit(单位): mm

Ball Screw Specifications	主要技术参数
Ball size 钢珠直径	$\phi 0.8$
Number of thread 螺纹条数	1
Thread direction 螺纹旋向	Right 右旋
Shaft root dia. 丝杠轴底径	$\phi 3.3$
Number of circuit 循环数	3.7×1
Shaft, Nut material 轴、螺母材质	SCM415H
Surface hardness 螺纹部表面硬度	HRC58~62 (Thread area)
Anti-rust treatment 防锈处理	Anti-rust oil 防锈油

Supported-side end-journal profile 支撑侧轴端加工形状

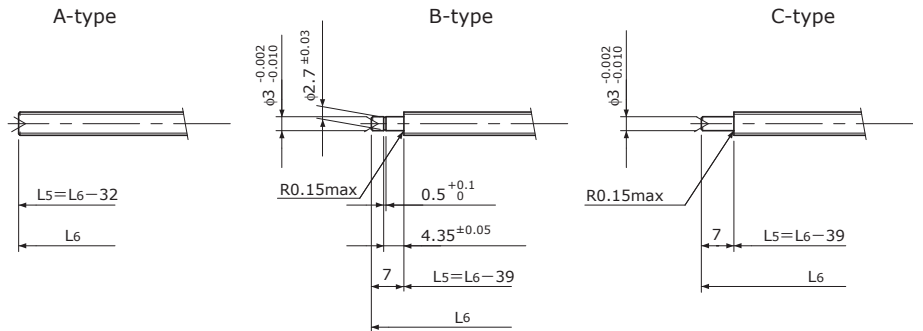

L_5 : Thread length after end-journal machining. 追加加工后的螺纹部长度
 L_6 : Total length after end-journal machining. 追加加工后的总长

Support-unit Recommendation	Supported-side	支撑侧	MSU-4CS/4GS, SUP03-S
推荐的支架组件	Fixed-side	固定侧	MSU-4C/4G, EK4

D-type : Other than the above. 上述以外的形状

Unit(单位): mm

Ball Screw Model 滚珠丝杠型号	Travel 行程	Grade 精度	Shaft length 丝杠轴长度				Lead accuracy 导程精度		Total Run-out 全跳动	Axial play 轴向间隙	Preload Torque 预压扭矩 Nm	Basic Load Rating 基本额定负载 N	
			L_1	L_2	L_3	L_4	Travel deviation 代表移动量误差 e_p	Variation 波动 V_u				Dynamic 额定动负载 C_a	Static 额定静负载 C_{0a}
SG0401-063R095C3	45	C3	63	66	72	95	± 0.008	0.008	0.025	0 Spacer Ball 间隔钢珠 (1:1)	~0.004	350	400
SG0401-083R115C3	65	C3	83	86	92	115	± 0.008	0.008	0.025				
SG0401-103R135C3	85	C3	103	106	112	135	± 0.010	0.008	0.035				
SG0401-063R095C5	45	C5	63	66	72	95	± 0.018	0.018	0.035	~0.005	—	560	790
SG0401-083R115C5	65	C5	83	86	92	115	± 0.018	0.018	0.035				
SG0401-103R135C5	85	C5	103	106	112	135	± 0.020	0.018	0.050				

Note) Please refer to p-A206 for order code of end-journal machining. 注)追加加工的公称型号指定方式请参照p-A206.