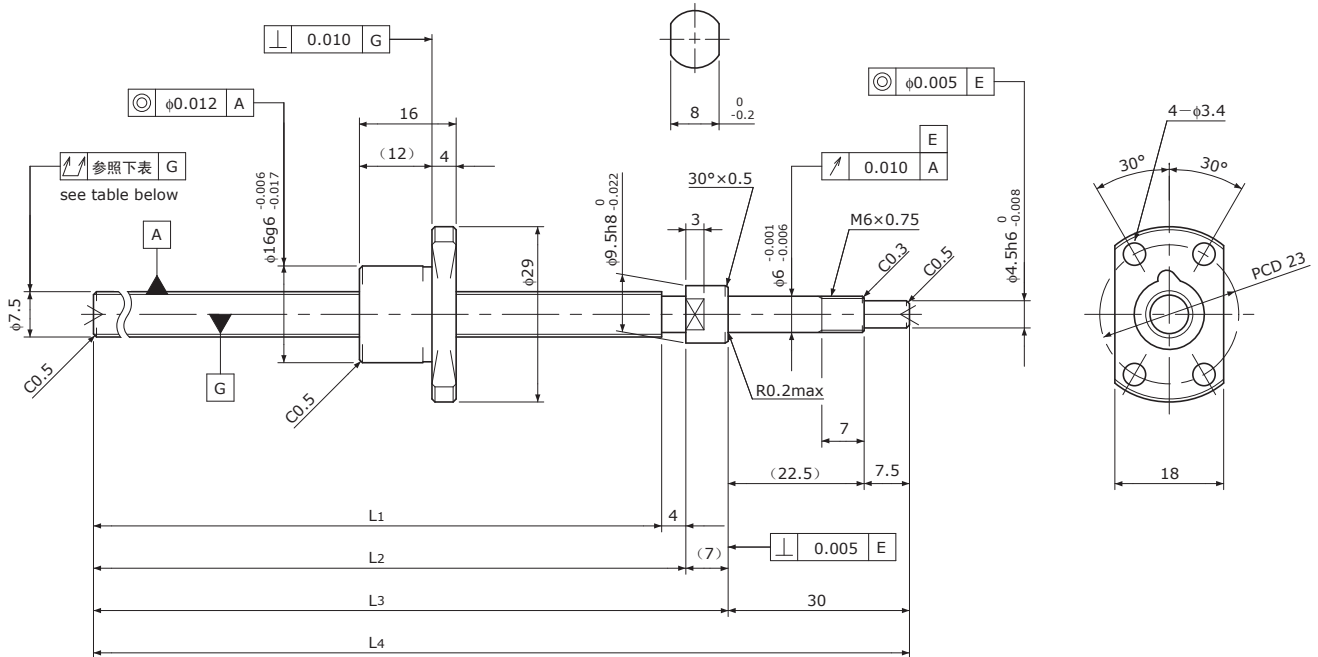

Standard products in stock SG series
 标准库存品 SG系列

SG0802.5 | Shaft dia.(轴径) $\phi 8$ | Lead(导程) 2.5mm

C5

Unit(单位): mm

Ball Screw Specifications	主要技术参数
Ball size 钢珠直径	$\phi 1.5875$
Number of thread 螺纹条数	1
Thread direction 螺纹旋向	Right 右旋
Shaft root dia. 丝杠轴底径	$\phi 6.3$
Number of circuit 循环数	2.7×1
Shaft, Nut material 轴、螺母材质	SCM415H
Surface hardness 螺纹部表面硬度	HRC58~62 (Thread area)
Anti-rust treatment 防锈处理	Anti-rust oil 防锈油

Supported-side end-journal profile 支撑侧轴端加工形状

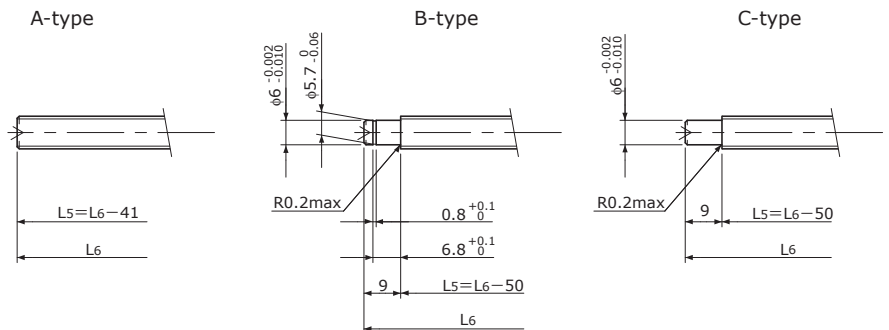

L_5 : Thread length after end-journal machining. 追加加工后的螺纹部长度
 L_6 : Total length after end-journal machining. 追加加工后的总长

Support-unit Recommendation	Supported-side	支撑侧	MSU-6CS/6GS, EF6
推荐的支架组件	Fixed-side	固定侧	MSU-6C/6G, EK6

D-type : Other than the above. 上述以外的形状

Unit(单位): mm

Ball Screw Model 滚珠丝杠型号	Travel 行程	Grade 精度	Shaft length 丝杠轴长度				Lead accuracy 导程精度		Total Run-out 全跳动	Axial play 轴向间隙	Preload Torque 预压扭矩 Nm	Basic Load Rating 基本额定负载 N	
			L ₁	L ₂	L ₃	L ₄	Travel deviation 代表移动量误差 e_p	Variation 波动 V_u				Dynamic 额定动负载 Ca	Static 额定静负载 Coa
SG0802.5-129R170C5	110	C5	129	133	140	170	± 0.020	0.018	0.050	~0.005	—	1850	3000
SG0802.5-209R250C5	190	C5	209	213	220	250	± 0.023	0.018	0.065				

Note) Please refer to p-A206 for order code of end-journal machining. 注)追加加工的公称型号指定方式请参照p-A206.