

SG0808

Shaft dia.(轴径) $\phi 8$ Lead(导程) 8mm

C5

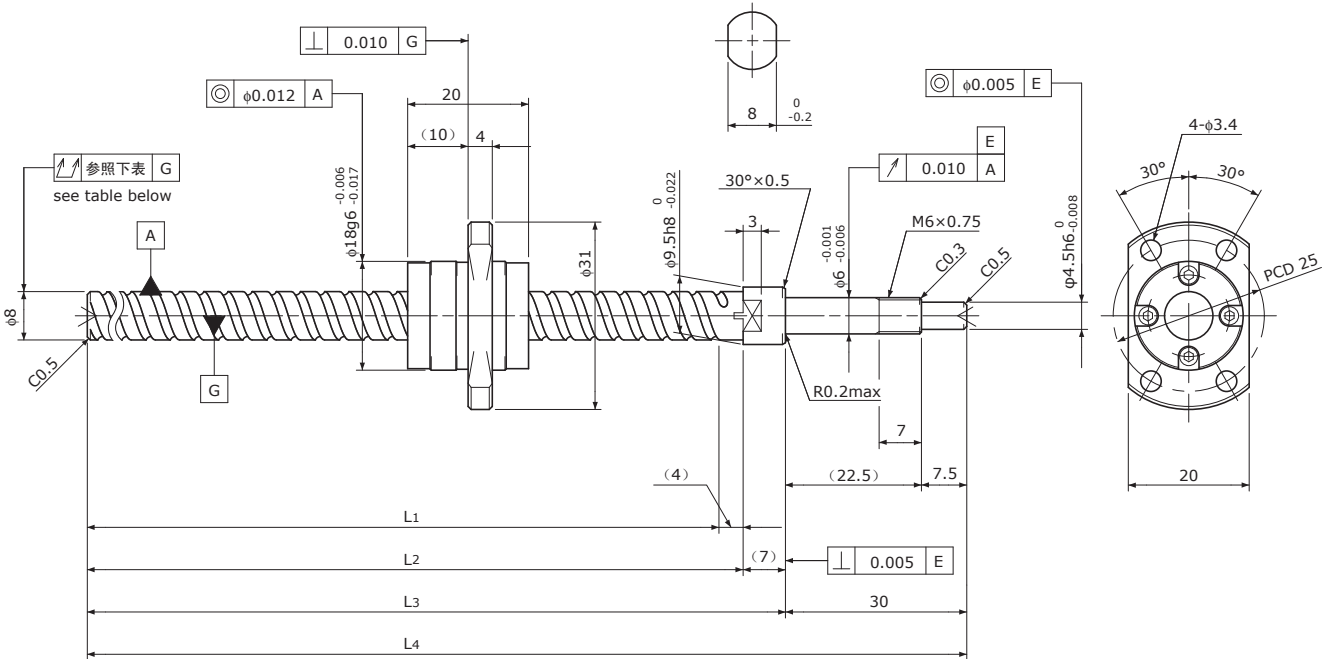

Unit(单位): mm

Ball Screw Specifications 主要技术参数	
Ball size 钢珠直径	$\phi 1.5875$
Number of thread 螺纹条数	2
Thread direction 螺纹旋向	Right 右旋
Shaft root dia. 丝杠轴底径	$\phi 6.7$
Number of circuit 循环数	1.6×2
Shaft, Nut material 轴、螺母材质	SCM415H
Surface hardness 螺纹部表面硬度	HRC58~62 (Thread area)
Anti-rust treatment 防锈处理	Anti-rust oil 防锈油

Supported-side end-journal profile 支撑侧轴端加工形状

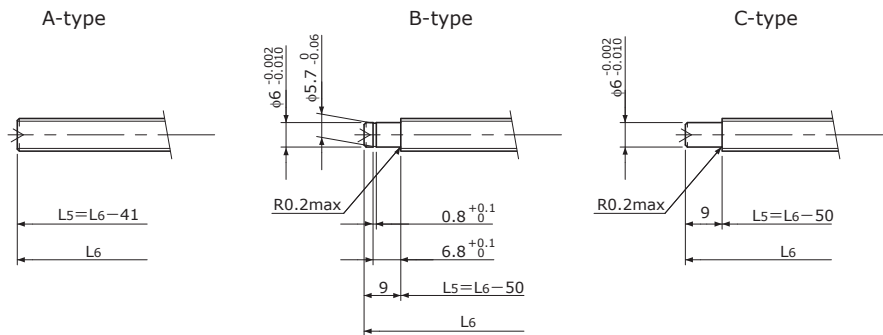

L₅: Thread length after end-journal machining. 追加加工后的螺纹部长度
L₆: Total length after end-journal machining. 追加加工后的总长

Support-unit Recommendation 推荐的支架组件	Supported-side 支撑侧	Fixed-side 固定侧
	MSU-6CS/6GS, EF6	MSU-6C/6G, EK6

D-type: Other than the above. 上述以外的形状

Unit(单位): mm

Ball Screw Model 滚珠丝杠型号	Travel 行程	Grade 精度	Shaft length 丝杠轴长度				Lead accuracy 导程精度		Total Run-out 全跳动	Axial play 轴向间隙	Preload Torque 预压扭矩 Nm	Basic Load Rating 基本额定负载 N	
			L ₁	L ₂	L ₃	L ₄	Travel deviation 代表移动量误差 e _p	Variation 波动 V _u				Dynamic 额定动负载 Ca	Static 额定静负载 Coa
SG0808-099R140C5	75	C5	99	103	110	140	± 0.018	0.018	0.050	~0.005	—	2200	3800
SG0808-209R250C5	185	C5	209	213	220	250	± 0.023	0.018	0.065				

Note) Please refer to p-A206 for order code of end-journal machining. 注) 追加加工的公称型号指定方式请参照p-A206.