

# SG1505

Shaft dia.(轴径) $\phi 15$  Lead(导程)5mm

C5

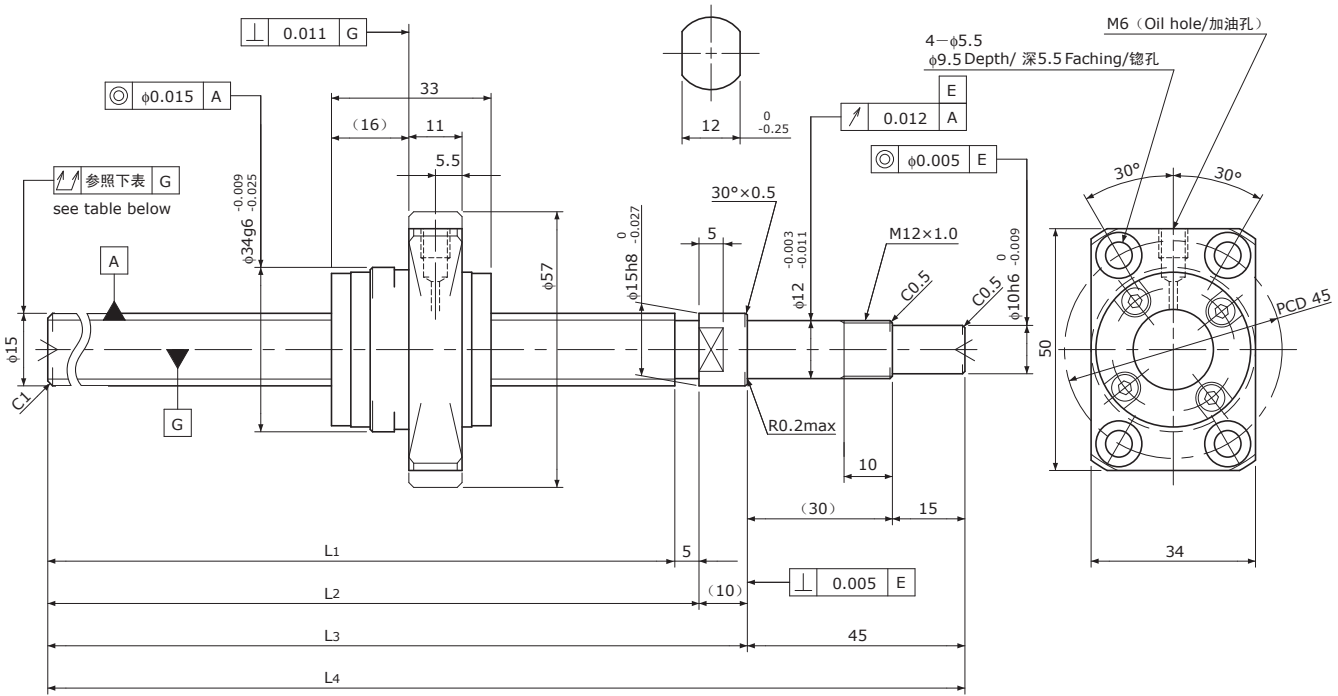

Unit(单位): mm

Ball Screw Specifications 主要技术参数	
Ball size 钢珠直径	$\phi 3.175$
Number of thread 螺纹条数	1
Thread direction 螺纹旋向	Right 右旋
Shaft root dia. 丝杠轴底径	$\phi 12.2$
Number of circuit 循环数	$3.7 \times 1$
Shaft, Nut material 轴、螺母材质	SCM415H
Surface hardness 螺纹部表面硬度	HRC58~62 (Thread area)
Anti-rust treatment 防锈处理	Anti-rust oil 防锈油

### Supported-side end-journal profile 支撑侧轴端加工形状

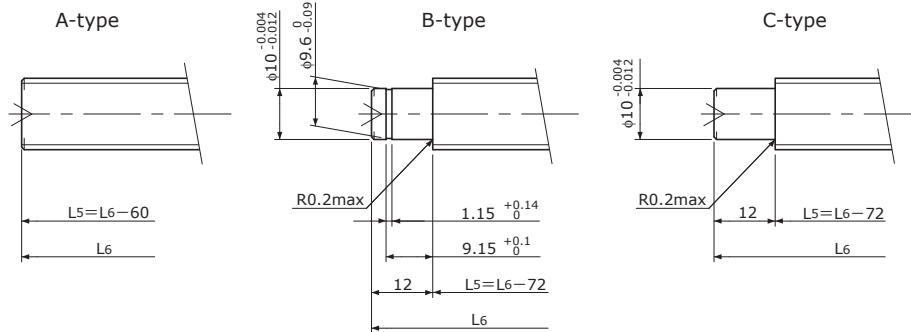

L5: Thread length after end-journal machining. 追加加工后的螺纹部长度  
L6: Total length after end-journal machining. 追加加工后的总长

### Support-unit Recommendation 推荐的支架组件

Supported-side 支撑侧	: EF12
Fixed-side 固定侧	: EK12

D-type : Other than the above. 上述以外的形状

Unit(单位): mm

Ball Screw Model 滚珠丝杠型号	Travel 行程	Grade 精度	Shaft length 丝杠轴长度				Lead accuracy 导程精度		Total Run-out 全跳动	Axial play 轴向间隙	Preload Torque 预压扭矩 Nm	Basic Load Rating 基本额定负载 N	
			L <sub>1</sub>	L <sub>2</sub>	L <sub>3</sub>	L <sub>4</sub>	Travel deviation 代表移动量误差 e <sub>p</sub>	Variation 波动 V <sub>u</sub>				Dynamic 额定动负载 Ca	Static 额定静负载 Coa
SG1505-340R400C5	305	C5	340	345	355	400	$\pm 0.025$	0.020	0.055	~0.005	—	8900	17000
SG1505-540R600C5	505	C5	540	545	555	600	$\pm 0.030$	0.023	0.075				

Note) Please refer to p-A206 for order code of end-journal machining. 注) 追加加工的公称型号指定方式请参照p-A206.