

# SG1510

 Shaft dia. (轴径)  $\phi 15$  Lead (导程) 10mm

# C5

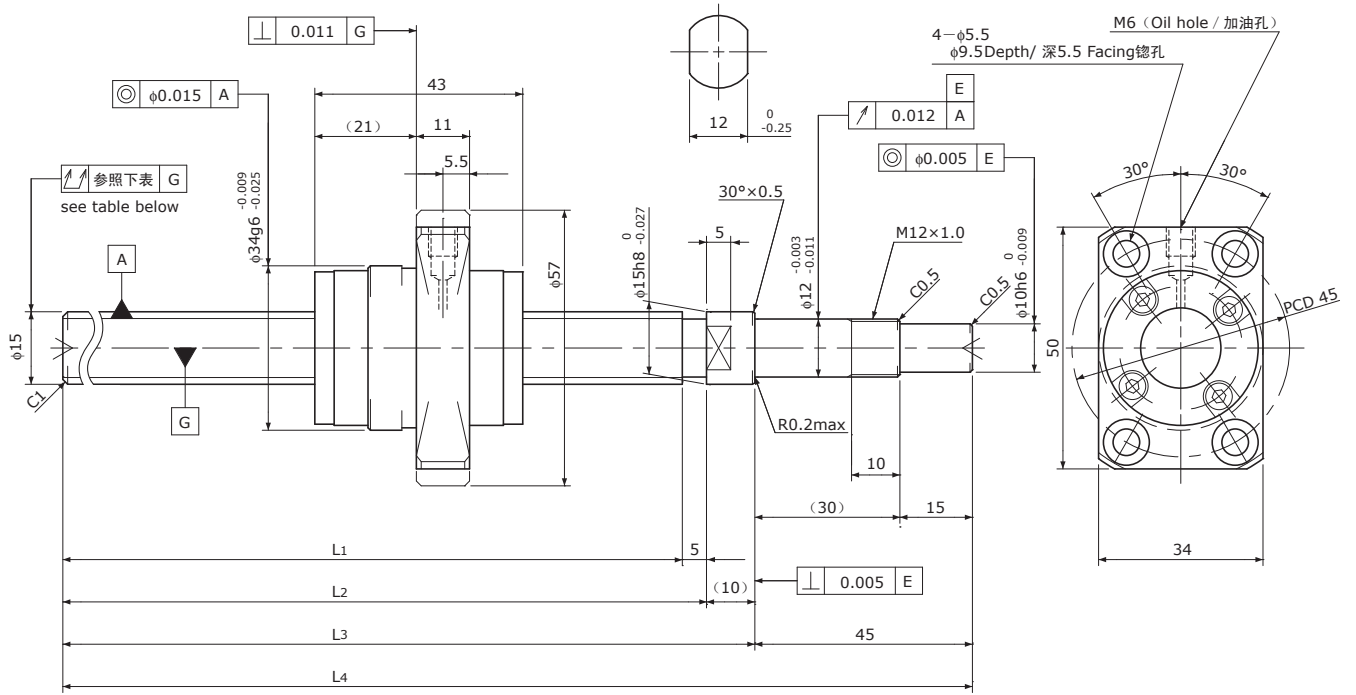

Unit (单位): mm

Ball Screw Specifications	主要技术参数
Ball size 钢珠直径	$\phi 3.175$
Number of thread 螺纹条数	2
Thread direction 螺纹旋向	Right 右旋
Shaft root dia. 丝杠轴底径	$\phi 12.2$
Number of circuit 循环数	$2.7 \times 2$
Shaft, Nut material 轴、螺母材质	SCM415H
Surface hardness 螺纹部表面硬度	HRC58~62 (Thread area)
Anti-rust treatment 防锈处理	Anti-rust oil 防锈油

Supported-side end-journal profile 支撑侧轴端加工形状

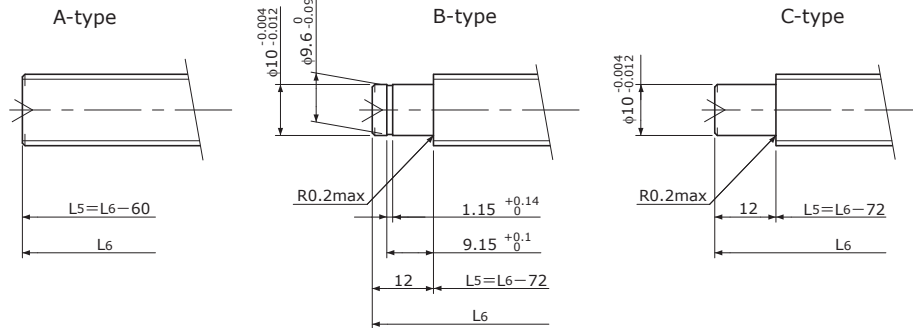

$L_5$ : Thread length after end-journal machining. 追加加工后的螺纹部长度  
 $L_6$ : Total length after end-journal machining. 追加加工后的总长

Support-unit Recommendation 推荐的支架组件

Supported-side 支撑侧	: EF12
Fixed-side 固定侧	: EK12

D-type: Other than the above. 上述以外的形状

Unit (单位): mm

Ball Screw Model 滚珠丝杠型号	Travel 行程	Grade 精度	Shaft length 丝杠轴长度				Lead accuracy 导程精度		Total Run-out 全跳动	Axial play 轴向间隙	Preload Torque 预压扭矩 Nm	Basic Load Rating 基本额定负载 N	
			L <sub>1</sub>	L <sub>2</sub>	L <sub>3</sub>	L <sub>4</sub>	Travel deviation 代表移动量误差 $e_p$	Variation 波动 $V_u$				Dynamic 额定动负载 Ca	Static 额定静负载 Coa
SG1510-340R400C5	295	C5	340	345	355	400	$\pm 0.025$	0.020	0.055	~0.005	—	12000	25000
SG1510-540R600C5	495	C5	540	545	555	600	$\pm 0.030$	0.023	0.075				

Note) Please refer to p-A206 for order code of end-journal machining. 注) 追加加工的公称型号指定方式请参照 p-A206。