

SR0402

 Shaft dia.(轴径) $\phi 4$ Lead(导程)2mm

Ct7&Ct10

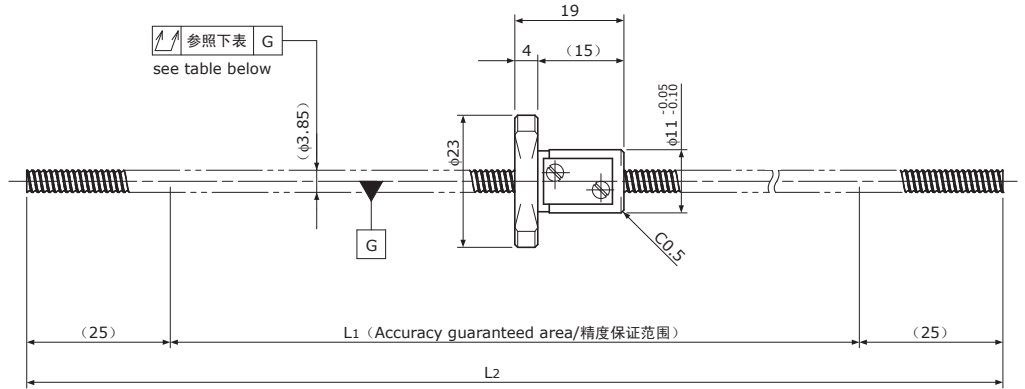
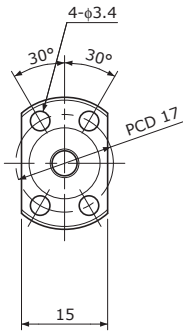

Unit(单位): mm

Ball Screw Specifications	主要技术参数	
Ball size 钢珠直径	$\phi 0.8$	
Number of thread 螺纹条数	1	
Thread direction 螺纹旋向	Right 右旋	
Shaft root dia. 丝杠轴底径	$\phi 3.3$	
Number of circuit 循环数	2.7×1	
Shaft, Nut material 轴、螺母材质	SCM415H	
Surface hardness 螺纹部表面硬度	HRC58~62 (Thread area)	
Anti-rust treatment 防锈处理	Anti-rust oil 防锈油	

Unit(单位): mm

Ball Screw Model 滚珠丝杠型号	Travel 行程	Grade 精度	Shaft length 丝杠轴长度		Lead accuracy 导程精度		Total Run-out 全跳动 \nearrow	Axial play 轴向间隙	Preload Torque 预压扭矩 Nm	Basic Load Rating 基本额定负载 N	
			L ₁	L ₂	Travel deviation 代表移动量误差 e _p	Variation 波动 V ₃₀₀				Dynamic 额定动负载 Ca	Static 额定静负载 Coa
SR0402-250R250C7	180	Ct7	200	250	± 0.03	—	0.200	~ 0.020	—	420	570
SR0402-250R250C10	180	Ct10	200	250	± 0.14	—	0.400	~ 0.050			

Note) Please designate end-journal profile with your sketch. 注) 轴端的追加加工请结合图纸进行指示。