

# SR0601

 Shaft dia.(轴径)  $\phi 6$  Lead(导程) 1mm

Ct7&amp;Ct10

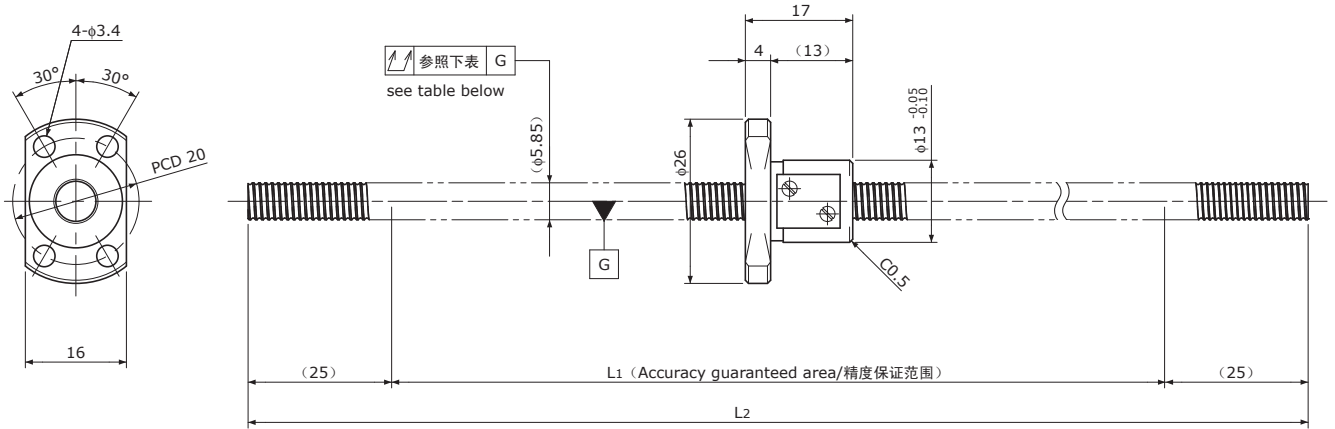

Unit(单位): mm

Ball Screw Specifications	主要技术参数
Ball size 钢珠直径	$\phi 0.8$
Number of thread 螺纹条数	1
Thread direction 螺纹旋向	Right 右旋
Shaft root dia. 丝杠轴底径	$\phi 5.3$
Number of circuit 循环数	$3.7 \times 1$
Shaft, Nut material 轴、螺母材质	SCM415H
Surface hardness 螺纹部表面硬度	HRC58~62 (Thread area)
Anti-rust treatment 防锈处理	Anti-rust oil 防锈油

Unit(单位): mm

Ball Screw Model 滚珠丝杠型号	Travel 行程	Grade 精度	Shaft length 丝杠轴长度		Lead accuracy 导程精度		Total Run-out 全跳动 $\nearrow$	Axial play 轴向间隙	Preload Torque 预压扭矩 Nm	Basic Load Rating 基本额定负载 N	
			L <sub>1</sub>	L <sub>2</sub>	Travel deviation 代表移动量误差 e <sub>p</sub>	Variation 波动 V <sub>300</sub>				Dynamic 额定动负载 Ca	Static 额定静负载 Coa
SR0601-300R300C7	230	Ct7	250	300	$\pm 0.04$	—	0.120	$\sim 0.020$	—	680	1200
SR0601-300R300C10	230	Ct10	250	300	$\pm 0.17$	—	0.240	$\sim 0.050$			

Note) Please designate end-journal profile with your sketch. 注) 轴端的追加加工请结合图纸进行指示。