

# SR0805

 Shaft dia.(轴径)  $\phi 8$  Lead(导程) 5mm

Ct7&amp;Ct10

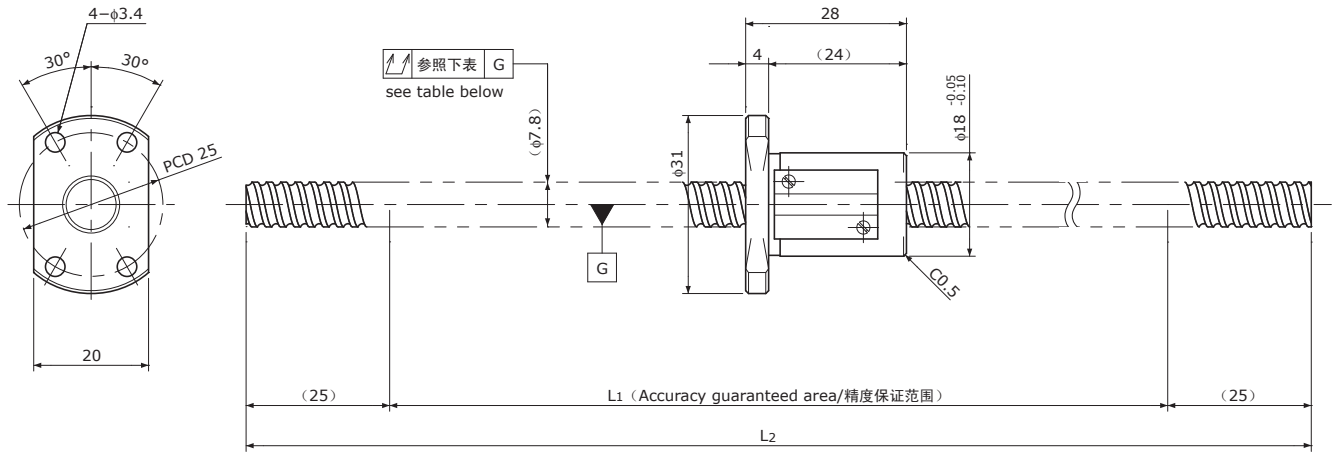

Unit(单位): mm

Ball Screw Specifications	主要技术参数	
Ball size 钢珠直径	$\phi 1.5875$	
Number of thread 螺纹条数	1	
Thread direction 螺纹旋向	Right 右旋	
Shaft root dia. 丝杠轴底径	$\phi 6.6$	
Number of circuit 循环数	$2.7 \times 1$	
Shaft, Nut material 轴、螺母材质	SCM415H	
Surface hardness 螺纹部表面硬度	HRC58~62 (Thread area)	
Anti-rust treatment 防锈处理	Anti-rust oil 防锈油	

Unit(单位): mm

Ball Screw Model 滚珠丝杠型号	Travel 行程	Grade 精度	Shaft length 丝杠轴长度		Lead accuracy 导程精度		Total Run-out 全跳动 $\nearrow$	Axial play 轴向间隙	Preload Torque 预压扭矩 Nm	Basic Load Rating 基本额定负载 N	
			L <sub>1</sub>	L <sub>2</sub>	Travel deviation 代表移动量误差 e <sub>p</sub>	Variation 波动 V <sub>300</sub>				Dynamic 额定动负载 Ca	Static 额定静负载 Coa
SR0805-400R400C7	320	Ct7	350	400	$\pm 0.06$	0.05	0.120	$\sim 0.020$	—	1850	3000
SR0805-400R400C10	320	Ct10	350	400	$\pm 0.24$	0.21	0.240	$\sim 0.050$			

Note) Please designate end-journal profile with your sketch. 注) 轴端的追加加工请结合图纸进行指示。