

# SR1002K

Compact Nut / 紧凑型螺母

Shaft dia. (轴径)  $\phi 10$  Lead (导程) 2mm

Ct7&Ct10

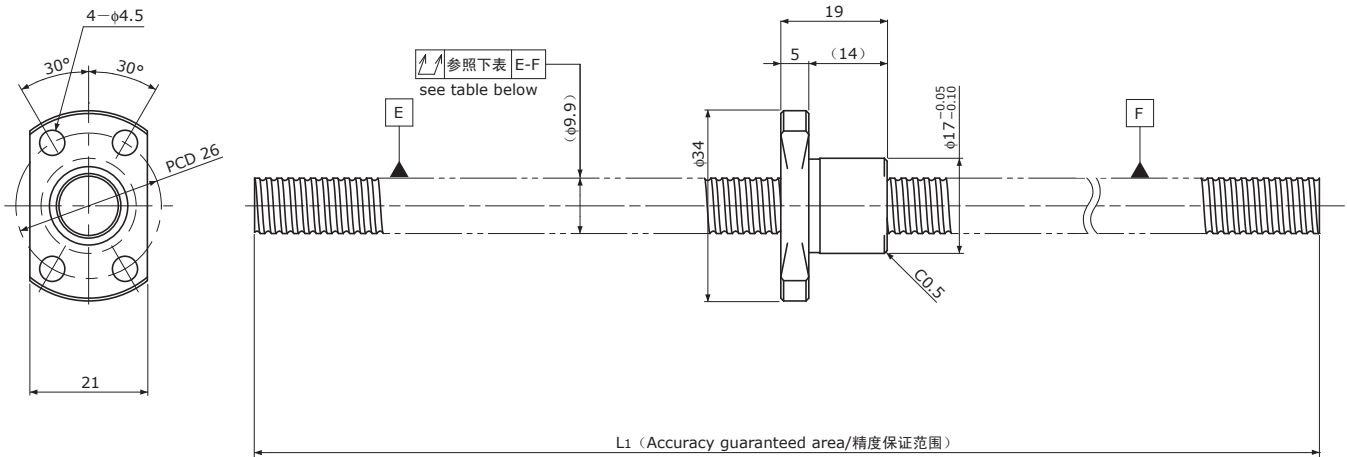

Unit(单位): mm

Ball Screw Specifications		主要技术参数
Ball size	钢珠直径	$\phi 1.2$
Number of thread	螺纹条数	1
Thread direction	螺纹旋向	Right 右旋
Shaft root dia.	丝杠轴底径	$\phi 9.0$
Number of circuit	循环数	1×3
Material 材质	Shaft 轴	S55C
	Nut 螺母	SCM415H
Surface hardness 螺纹部表面硬度		HRC58~ (Thread area)
Anti-rust treatment 防锈处理		Anti-rust oil 防锈油

Unit(单位): mm

Ball Screw Model 滚珠丝杠型号	Travel 行程	Grade 精度	Shaft length 丝杠轴长度		Lead accuracy 导程精度		Total Run-out 全跳动	Axial play 轴向间隙	Preload Torque 预压扭矩 Nm	Basic Load Rating 基本额定负载 N	
			L <sub>1</sub>	L <sub>2</sub>	Travel deviation 代表移动量误差 e <sub>p</sub>	Variation 波动 V <sub>300</sub>				Dynamic 额定动负载 Ca	Static 额定静负载 Coa
SR1002K-230R230C7	200	Ct7	230	—	±0.03	—	0.080	~0.020	—	1450	3000
SR1002K-230R230C10	200	Ct10	230	—	±0.16	—	0.160	~0.050			

Note) Please designate end-journal profile with your sketch. 注) 轴端的追加加工请结合图纸进行指示。