

Standard products in stock SR series  
标准库存品 SR系列

SR1015

Shaft dia.(轴径) $\phi 10$  Lead(导程)15mm

Ct7&amp;Ct10

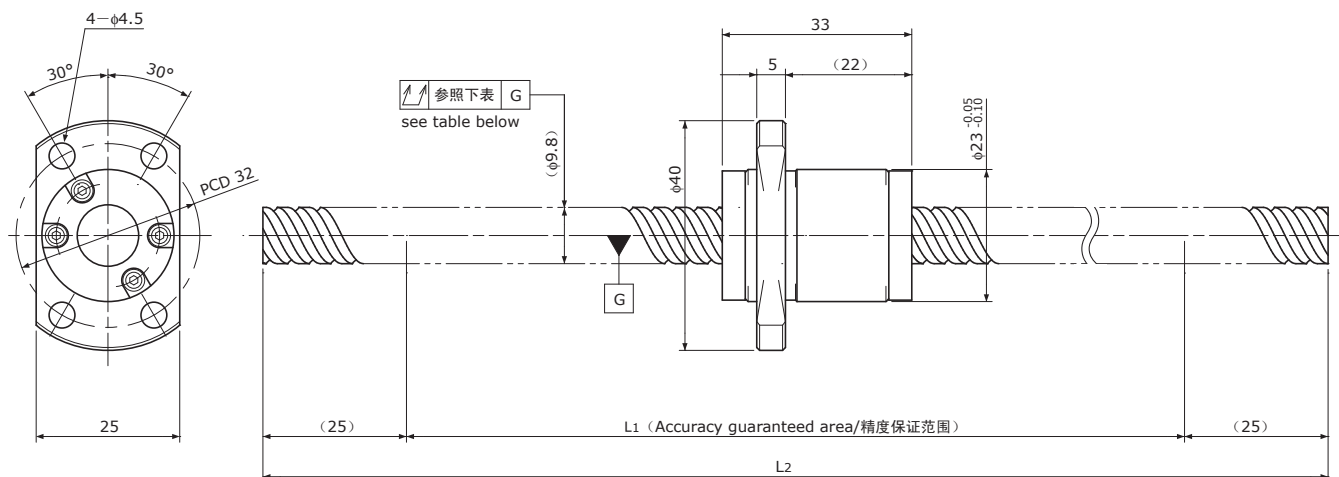

Unit(单位): mm

Ball Screw Specifications 主要技术参数	
Ball size 钢珠直径	$\phi 2.0$
Number of thread 螺纹条数	2
Thread direction 螺纹旋向	Right 右旋
Shaft root dia. 丝杠轴底径	$\phi 8.4$
Number of circuit 循环数	$1.6 \times 2$
Shaft, Nut material 轴、螺母材质	SCM415H
Surface hardness 螺纹部表面硬度	HRC58~62 (Thread area)
Anti-rust treatment 防锈处理	Anti-rust oil 防锈油

Unit(单位): mm

Ball Screw Model 滚珠丝杠型号	Travel 行程	Grade 精度	Shaft length 丝杠轴长度		Lead accuracy 导程精度		Total Run-out 全跳动 $\uparrow\uparrow$	Axial play 轴向间隙	Preload Torque 预压扭矩 Nm	Basic Load Rating 基本额定负载 N	
			L <sub>1</sub>	L <sub>2</sub>	Travel deviation 代表移动量误差 e <sub>p</sub>	Variation 波动 V <sub>300</sub>				Dynamic 额定动负载 Ca	Static 额定静负载 Coa
SR1015-450R450C7	365	Ct7	400	450	$\pm 0.06$	0.05	0.120	~0.020	—	3300	6400
SR1015-450R450C10	365	Ct10	400	450	$\pm 0.28$	0.21	0.240	~0.050			

(Note) Please designate end-journal profile with your sketch. 注)轴端的追加加工请结合图纸进行指示。