

SR1202

Shaft dia.(轴径) $\phi 12$ Lead(导程)2mm

Ct7&Ct10

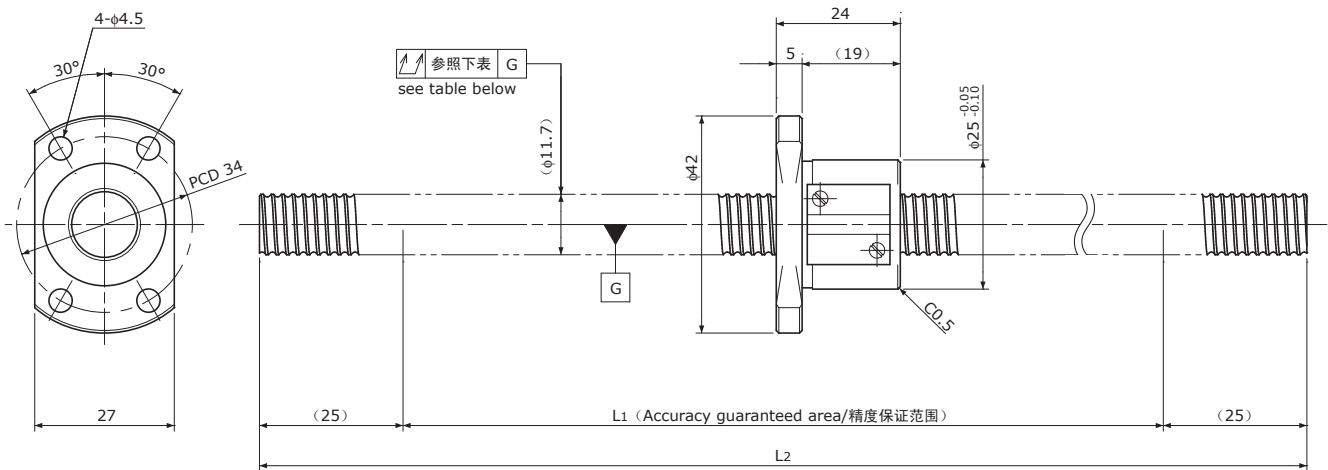

Unit(单位): mm

Ball Screw Specifications		主要技术参数
Ball size 钢珠直径		$\phi 1.5875$
Number of thread 螺纹条数		1
Thread direction 螺纹旋向	Right 右旋	
Shaft root dia. 丝杠轴底径		$\phi 10.6$
Number of circuit 循环数		3.7×1
Shaft, Nut material 轴、螺母材质		SCM415H
Surface hardness 螺纹部表面硬度		HRC58~62 (Thread area)
Anti-rust treatment 防锈处理		Anti-rust oil 防锈油

Unit(单位): mm

Ball Screw Model 滚珠丝杠型号	Travel 行程	Grade 精度	Shaft length 丝杠轴长度		Lead accuracy 导程精度		Total Run-out 全跳动	Axial play 轴向间隙	Preload Torque 预压扭矩 Nm	Basic Load Rating 基本额定负载 N	
			L ₁	L ₂	Travel deviation 代表移动量误差 e _p	Variation 波动 V ₃₀₀				Dynamic 额定动负载 Ca	Static 额定静负载 Coa
SR1202-450R450C7	375	Ct7	400	450	± 0.06	0.05	0.080	~0.020	—	3000	6400
SR1202-450R450C10	375	Ct10	400	450	± 0.28	0.21	0.160	~0.050			

Note) Please designate end-journal profile with your sketch. 注) 轴端的追加加工请结合图纸进行指示。