

Standard products in stock SR series  
标准库存品 SR系列

SR1510

Shaft dia.(轴径) $\phi 15$  Lead(导程)10mm

Ct7&amp;Ct10

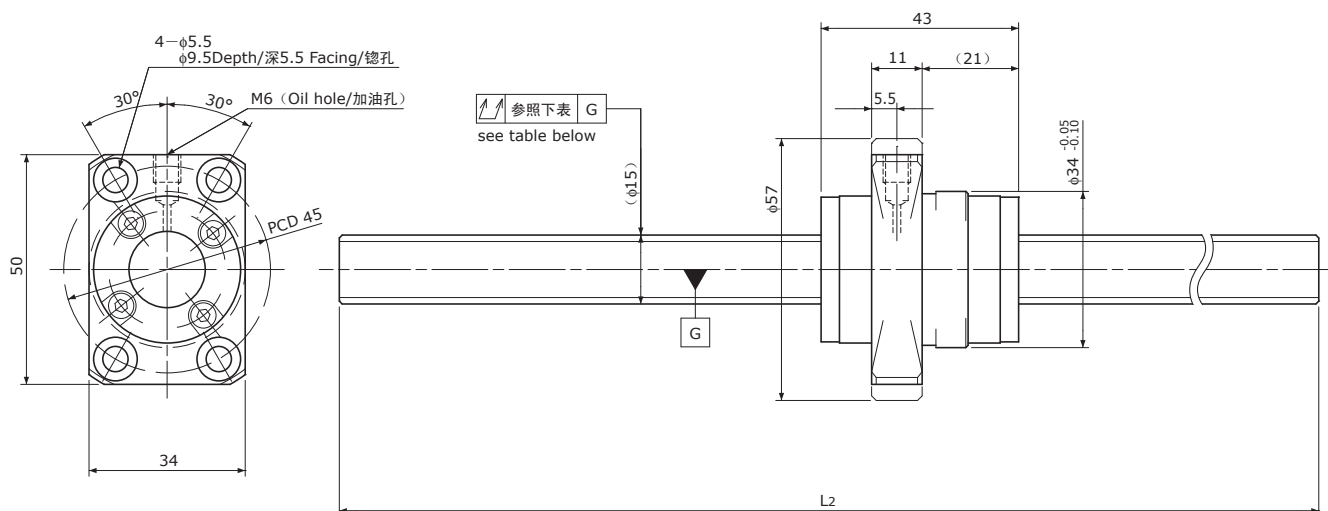

Unit(单位): mm

Ball Screw Specifications		主要技术参数
Ball size	钢珠直径	$\phi 3.175$
Number of thread	螺纹条数	2
Thread direction	螺纹旋向	Right 右旋
Shaft root dia.	丝杠轴底径	$\phi 12.2$
Number of circuit	循环数	$2.7 \times 2$
Material 材质	Shaft 轴	SUJ2
	Nut 螺母	SCM415
Surface hardness 螺纹部表面硬度		HRC58~62 (Thread area)
Anti-rust treatment 防锈处理		Anti-rust oil 防锈油

Unit(单位): mm

Ball Screw Model 滚珠丝杠型号	Travel 行程	Grade 精度	Shaft length 丝杠轴长度		Lead accuracy 导程精度		Total Run-out 全跳动 $\uparrow$	Axial play 轴向间隙	Preload Torque 预压扭矩 Nm	Basic Load Rating 基本额定负载 N	
			L <sub>1</sub>	L <sub>2</sub>	Travel deviation 代表移动量误差 e <sub>p</sub>	Variation 波动 V <sub>300</sub>				Dynamic 额定动负载 Ca	Static 额定静负载 Coa
SR1510-1000R1000C7	955	Ct7	—	1000	$\pm 0.17$	0.05	0.200	~0.020	—	12000	25000
SR1510-1000R1000C10	955	Ct10	—	1000	$\pm 0.7$	0.21	0.400	~0.050	—	12000	25000

(Note) Please designate end-journal profile with your sketch. 注)轴端的追加加工请结合图纸进行指示。