

SSR0801

Stainless 不锈钢

Shaft dia.(轴径) $\phi 8$ Lead(导程) 1mm

Ct7&Ct10

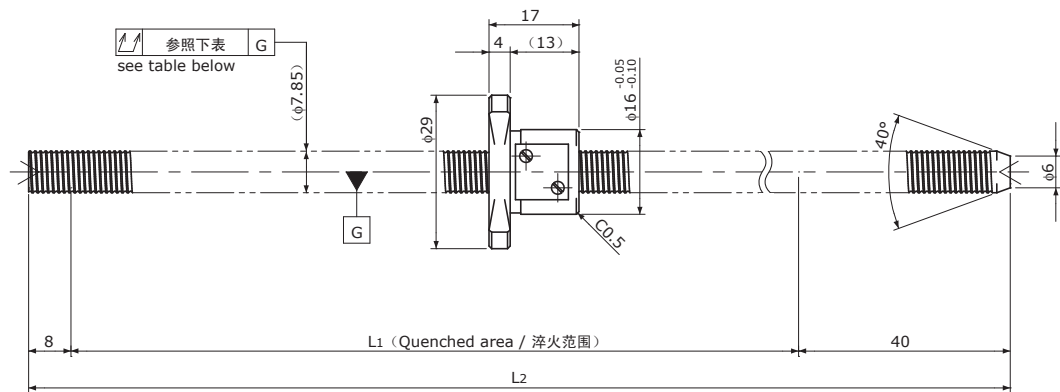
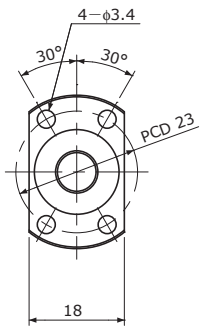

Unit(单位): mm

Ball Screw Specifications 主要技术参数	
Ball size 钢珠直径	$\phi 0.8$
Number of thread 螺纹条数	1
Thread direction 螺纹旋向	Right 右旋
Shaft root dia. 丝杠轴底径	$\phi 7.3$
Number of circuit 循环数	3.7×1
Shaft, Nut material 轴、螺母材质	SUS440C
Surface hardness 螺纹部表面硬度	HRC55~ (Thread area)
Anti-rust treatment 防锈处理	Anti-rust oil 防锈油

Unit(单位): mm

Ball Screw Model 滚珠丝杠型号	Travel 行程	Grade 精度	Shaft length 丝杠轴长度		Lead accuracy 导程精度		Total Run-out 全跳动	Axial play 轴向间隙	Preload Torque 预压扭矩 Nm	Basic Load Rating 基本额定负载 N	
			L ₁	L ₂	Travel deviation 代表移动量误差 e _p	Variation 波动 V ₃₀₀				Dynamic 额定动负载 Ca	Static 额定静负载 Coa
SSR0801-400C7	335	Ct7	352	400	± 0.06	0.05	0.120	~0.020	—	630	1250
SSR0801-400C10	335	Ct10	352	400	± 0.24	0.21	0.240	~0.050			

Note) Please designate end-journal profile with your sketch. 注) 轴端的追加加工请结合图纸进行指示。