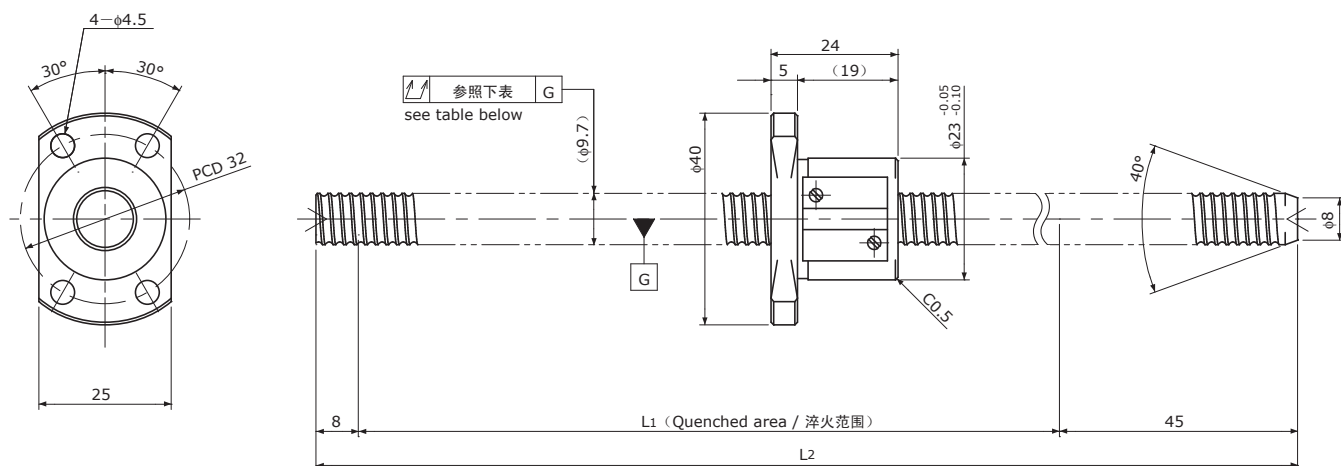

Standard products in stock SSR series  
 标准库存品 SSR系列

**SSR1002**

Stainless 不锈钢

 Shaft dia.(轴径)  $\phi 10$  Lead(导程) 2mm

**Ct7&Ct10**

Unit(单位): mm

Ball Screw Specifications	主要技术参数
Ball size 钢珠直径	$\phi 1.5875$
Number of thread 螺纹条数	1
Thread direction 螺纹旋向	Right 右旋
Shaft root dia. 丝杠轴底径	$\phi 8.6$
Number of circuit 循环数	$3.7 \times 1$
Shaft, Nut material 轴、螺母材质	SUS440C
Surface hardness 螺纹部表面硬度	HRC55~ (Thread area)
Anti-rust treatment 防锈处理	Anti-rust oil 防锈油

Unit(单位): mm

Ball Screw Model 滚珠丝杠型号	Travel 行程	Grade 精度	Shaft length 丝杠轴长度		Lead accuracy 导程精度		Total Run-out 全跳动	Axial play 轴向间隙	Preload Torque 预压扭矩 Nm	Basic Load Rating 基本额定负载 N	
			L <sub>1</sub>	L <sub>2</sub>	Travel deviation 代表移动量误差 e <sub>p</sub>	Variation 波动 V <sub>300</sub>				Dynamic 额定动负载 Ca	Static 额定静负载 Coa
SSR1002-400C7	320	Ct7	347	400	$\pm 0.06$	0.05	0.080	$\sim 0.020$	—	2200	4000
SSR1002-400C10	320	Ct10	347	400	$\pm 0.24$	0.21	0.160	$\sim 0.050$			

Note) Please designate end-journal profile with your sketch. 注) 轴端的追加加工请结合图纸进行指示。