

SRT0808

Shaft dia.(轴径) $\phi 8$ Lead(导程) 8mm

Ct7&Ct10

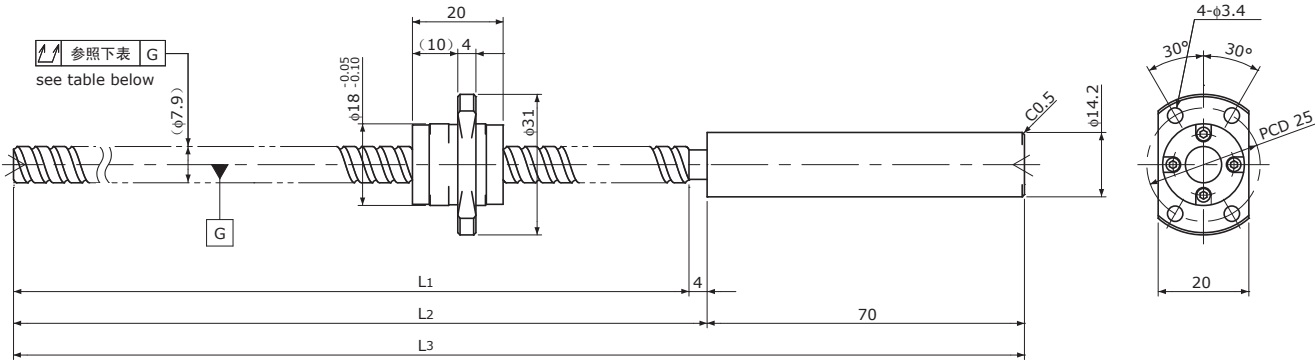

Unit(单位): mm

Ball Screw Specifications 主要技术参数		
Ball size 钢珠直径		$\phi 1.5875$
Number of thread 螺纹条数		2
Thread direction 螺纹旋向		Right 右旋
Shaft root dia. 丝杠轴底径		$\phi 6.7$
Number of circuit 循环数		1.6×2
Material 材质	Shaft 轴	SCM415H+SUS303
	Nut 螺母	SCM415H
Surface hardness 螺纹部表面硬度		HRC58~(Thread area)
Anti-rust treatment 防锈处理		Anti-rust oil 防锈油

End-journal profile 轴端加工形状 Supported-side 支撑侧 Fixed-side 固定侧

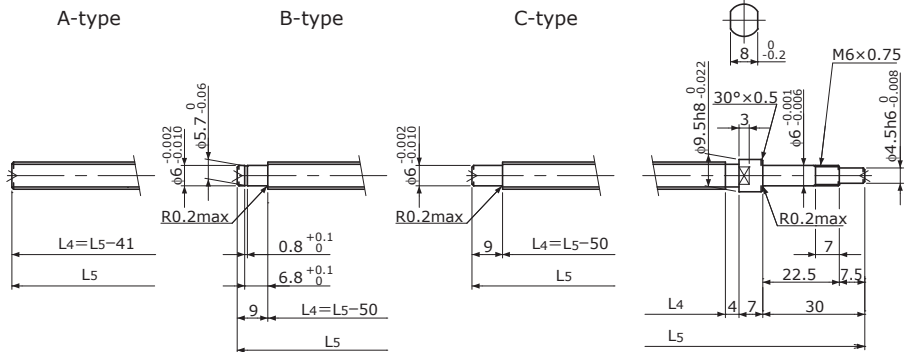

L4: Thread length after end-journal machining. 追加加工后的螺纹部长度
L5: Total length after end-journal machining. 追加加工后的总长

Support-unit Recommendation 推荐的支架组件	Supported-side 支撑侧	MSU-6CS/6GS, EF6
	Fixed-side 固定侧	MSU-6C/6G, EK6

D-type : Other than the above. 上述以外的形状

Unit(单位): mm

Ball Screw Model 滚珠丝杠型号	Travel 行程	Grade 精度	Shaft length 丝杠轴长度			Lead accuracy 导程精度		Total Run-out 全跳动	Axial play 轴向间隙	Preload Torque 预压扭矩 Nm	Basic Load Rating 基本额定负载 N	
			L ₁	L ₂	L ₃	Travel deviation 代表移动量误差 e _p	Variation 波动 V ₃₀₀				Dynamic 额定动负载 Ca	Static 额定静负载 Coa
SRT0808-196R270C7	175	Ct7	196	200	270	± 0.03	—	0.080	~0.020	—	2200	3800
SRT0808-356R430C7	335	Ct7	356	360	430	± 0.06	0.05	0.120				
SRT0808-196R270C10	175	Ct10	196	200	270	± 0.13	—	0.160	~0.050	—	2200	3800
SRT0808-356R430C10	335	Ct10	356	360	430	± 0.24	0.21	0.240				

Note) Please refer to p-A287 for order code of end-journal machining. 注)追加加工的公称型号指定方式请参照p-A287.