

# SRT1005 | Shaft dia.(轴径)φ10 Lead(导程)5mm | Ct7&Ct10

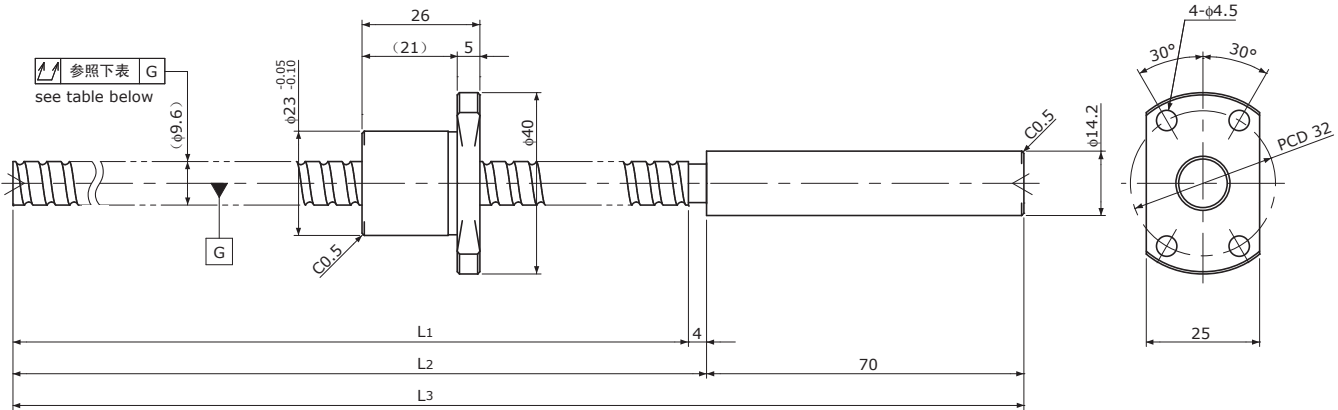

Unit(单位): mm

Ball Screw Specifications 主要技术参数	
Ball size 钢珠直径	φ2.0
Number of thread 螺纹条数	1
Thread direction 螺纹旋向	Right 右旋
Shaft root dia. 丝杠轴底径	φ8.2
Number of circuit 循环数	2.7×1
Material 材质	Shaft 轴 SCM415H+SUS303
	Nut 螺母 SCM415H
Surface hardness 螺纹部表面硬度	HRC58~(Thread area)
Anti-rust treatment 防锈处理	Anti-rust oil 防锈油

End-journal profile 轴端加工形状 Supported-side 支撑侧 Fixed-side 固定侧

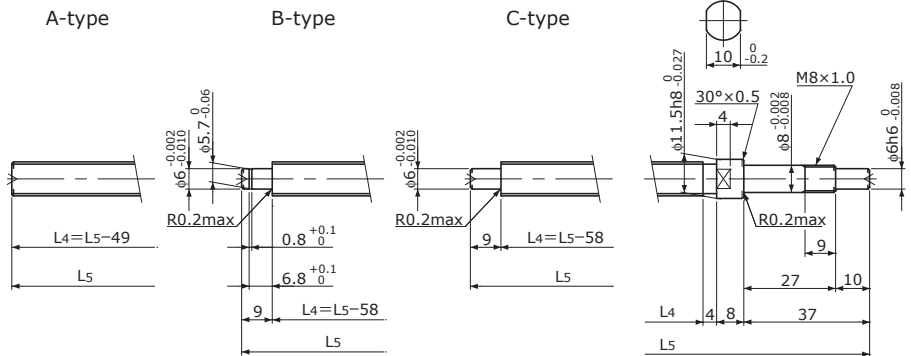

L4: Thread length after end-journal machining. 追加加工后的螺纹部长度  
L5: Total length after end-journal machining. 追加加工后的总长

Support-unit Recommendation 推荐的支架组件	Supported-side 支撑侧	Fixed-side 固定侧
	MSU-8CS/8GS, EF8	MSU-8C/8G, EK8

D-type : Other than the above. 上述以外的形状

Unit(单位): mm

Ball Screw Model 滚珠丝杠型号	Travel 行程	Grade 精度	Shaft length 丝杠轴长度			Lead accuracy 导程精度		Total Run-out 全跳动	Axial play 轴向间隙	Preload Torque 预压扭矩 Nm	Basic Load Rating 基本额定负载 N	
			L1	L2	L3	Travel deviation 代表移动量误差 e <sub>p</sub>	Variation 波动 V <sub>300</sub>				Dynamic 额定动负载 Ca	Static 额定静负载 Coa
SRT1005-196R270C7	170	Ct7	196	200	270	±0.03	—	0.080	~0.020	—	3000	5200
SRT1005-396R470C7	370	Ct7	396	400	470	±0.06	0.05	0.120				
SRT1005-196R270C10	170	Ct10	196	200	270	±0.13	—	0.160	~0.050	—	3000	5200
SRT1005-396R470C10	370	Ct10	396	400	470	±0.27	0.21	0.240				

Note) Please refer to p-A287 for order code of end-journal machining. 注)追加加工的公称型号指定方式请参照p-A287。