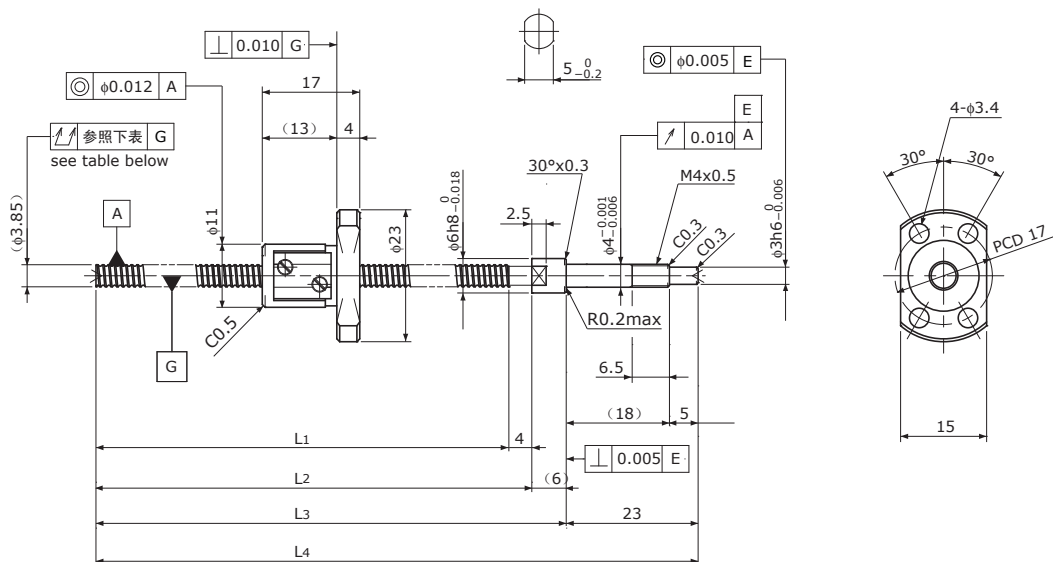

Standard products in stock PSRT series
 标准库存品 PSRT系列

PSRT0401

 Shaft dia.(轴径) $\phi 4$ Lead(导程) 1mm

C5

Unit(单位): mm

Ball Screw Specifications 规格	
Ball size 钢珠直径	$\phi 0.8$
Number of thread 螺纹条数	1
Thread direction 螺纹方向	Right 右
Shaft root dia. 丝杠轴低径	$\phi 3.3$
Number of circuit 循环数	3.7×1
Material 材质	Shaft 轴 S55C+SUS303 Nut 螺母 SCM415H
Surface hardness 螺纹部表面硬度	HRC58~ (Thread area)
Lubrication 润滑剂	KSS Original Grease MSG No.2

Supported-side end-journal profile 支撑侧轴端加工形状

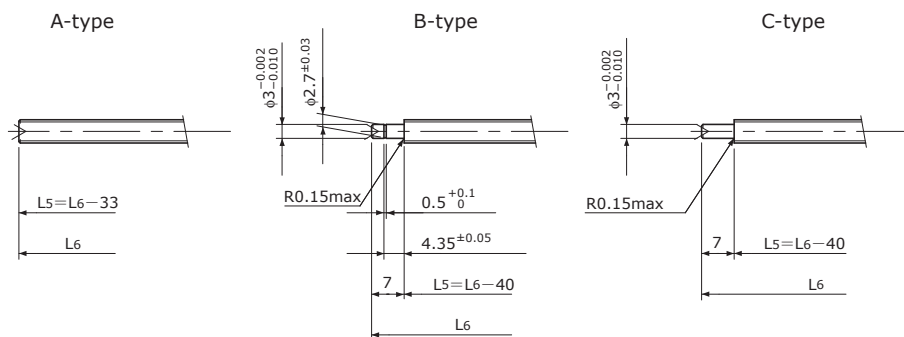

L5: Thread length after end-journal machining. 追加加工后的螺纹部长度
 L6: Total length after end-journal machining. 追加加工后的总长

Support-unit Recommendation 推荐的支撑单元	Supported-side 支撑侧 : MSU-4CS/4GS, SUP03-S
	Fixed-side 固定侧 : MSU-4C/4G, EK4

D-type : Other than the above. 上述以外的形状

Unit(单位): mm

Ball Screw Model 滚珠丝杠型号	Travel 行程	Shaft length 丝杠轴长度				Travel deviation 代表移动量误差 e_p	Total Run-out 全跳动 \nearrow	Axial play 轴向间隙	Basic Load Rating 基本额定负载 N	
		L1	L2	L3	L4				Dynamic 额定动负载 C_a	Static 额定静负载 C_{0a}
PSRT0401-72R105C5	50	72	76	82	105	± 0.018	0.035	~ 0.005	560	790

Note) Please refer to page A-321 for order code of end-journal machining. 注)追加加工的公称型号指定方法,请参照A-321页