

PSRT0601

Shaft dia.(轴径)φ6 Lead(导程)1mm

C5

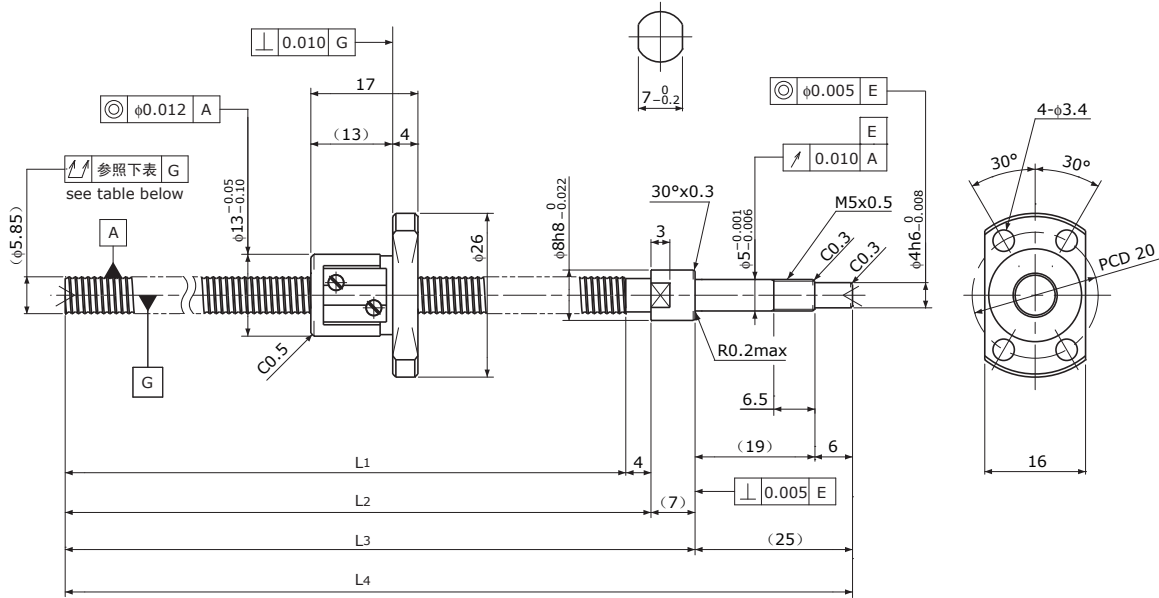

Unit(单位):mm

Ball Screw Specifications 规格	
Ball size 钢珠直径	φ 0.8
Number of thread 螺纹条数	1
Thread direction 螺纹方向	Right 右
Shaft root dia. 丝杠轴低径	φ 5.3
Number of circuit 循环数	3.7×1
Material 材质	Shaft 轴 S55C+SUS303
	Nut 螺母 SCM415H
Surface hardness 螺纹部表面硬度	HRC58~ (Thread area)
Lubrication 润滑剂	KSS Original Grease MSG No.2

Supported-side end-journal profile 支撑侧轴端加工形状

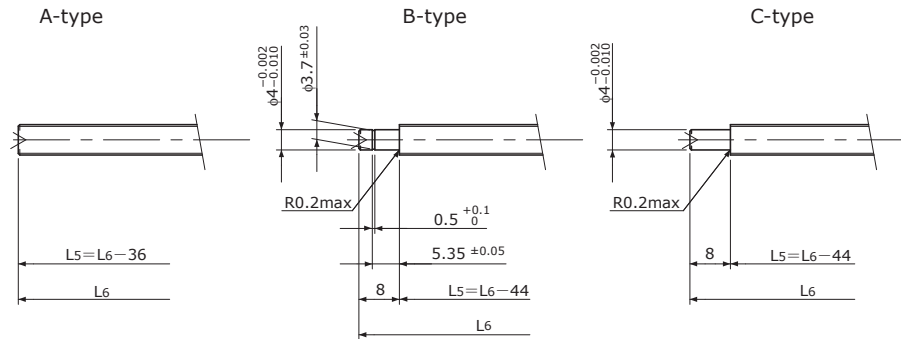

L5: Thread length after end-journal machining. 追加工后的螺纹部长度
L6: Total length after end-journal machining. 追加工后的总长

Support-unit Recommendation 推荐的支撑单元	Supported-side 支撑侧 : MSU-5CS/5GS, SUP04-S
	Fixed-side 固定侧 : MSU-5C/5G, EK5

D-type : Other than the above. 上述以外的形状

Unit(单位):mm

Ball Screw Model 滚珠丝杠型号	Travel 行程	Shaft length 丝杠轴长度				Travel deviation 代表移动量误差 e_p	Total Run-out 全跳动 \nearrow	Axial play 轴向间隙	Basic Load Rating 基本额定负载 N	
		L ₁	L ₂	L ₃	L ₄				Dynamic 额定动负载 C_a	Static 额定静负载 C_{0a}
PSRT0601-89R125C5	65	89	93	100	125	±0.018	0.035	~0.005	680	1200

Note) Please refer to page A-321 for order code of end-journal machining. 注)追加工的公称型号指定方法,请参照A-321页