

# PSR0812

 Shaft dia.(轴径) $\phi 8$  Lead(导程)12mm

# C5

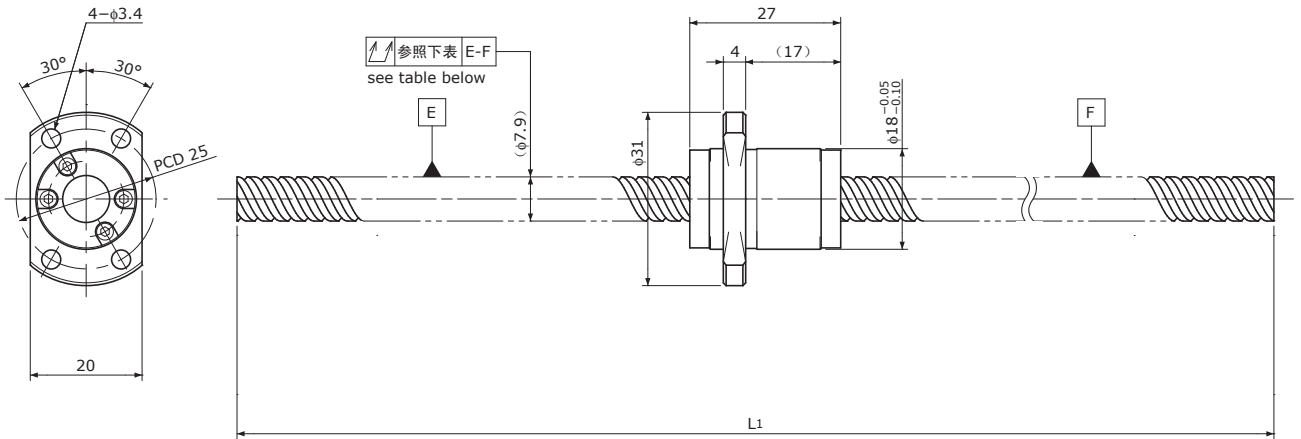

Unit(单位): mm

Ball Screw Specifications 规格		
Ball size 钢珠直径	$\phi 1.5875$	
Number of thread 螺纹条数	2	
Thread direction 螺纹方向	Right 右	
Shaft root dia. 丝杠轴低径	$\phi 6.7$	
Number of circuit 循环数	$1.6 \times 2$	
Material 材质	Shaft 轴	S55C
	Nut 螺母	SCM415H
Surface hardness 螺纹部表面硬度	HRC58~ (Thread area)	
Anti-rust treatment 防锈处理	Anti-rust oil 防锈油	

Unit(单位): mm

Ball Screw Model 滚珠丝杠型号	Travel 行程	Shaft length 丝杠轴长度	Travel deviation 代表移动量误差 $e_p$	Total Run-out 全跳动 $\nearrow$	Axial play 轴向间隙	Basic Load Rating 基本额定负载 N	
		$L_1$				Dynamic 额定动负载 $C_a$	Static 额定静负载 $C_{0a}$
PSR0812-230R230C5	195	230	$\pm 0.023$	0.065	$\sim 0.005$	2200	4000

Note) Please designate end-journal profile with your sketch. 注)轴端追加工请提供图纸。