

PSRT1002K

Compact Nut / 紧凑型螺母
Shaft dia. (轴径) $\phi 10$ Lead (导程) 2mm

C5

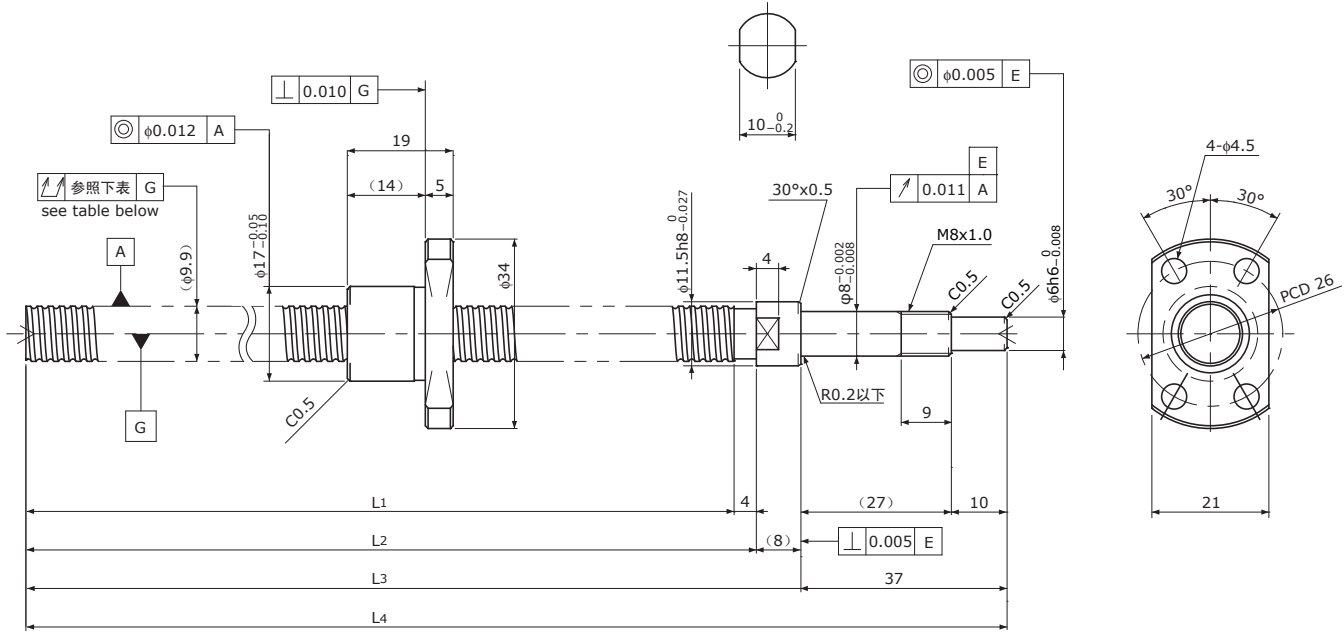

Unit (单位): mm

Ball Screw Specifications 规格	
Ball size 钢珠直径	$\phi 1.2$
Number of thread 螺纹条数	1
Thread direction 螺纹方向	Right 右
Shaft root dia. 丝杠轴低径	$\phi 9.0$
Number of circuit 循环数	1×3
Material 材质	Shaft 轴 S55C+SUS303
	Nut 螺母 SCM415H
Surface hardness 螺纹部表面硬度	HRC58~ (Thread area)
Lubrication 润滑剂	KSS Original Grease MSG No.2

Supported-side end-journal profile 支撑侧轴端加工形状

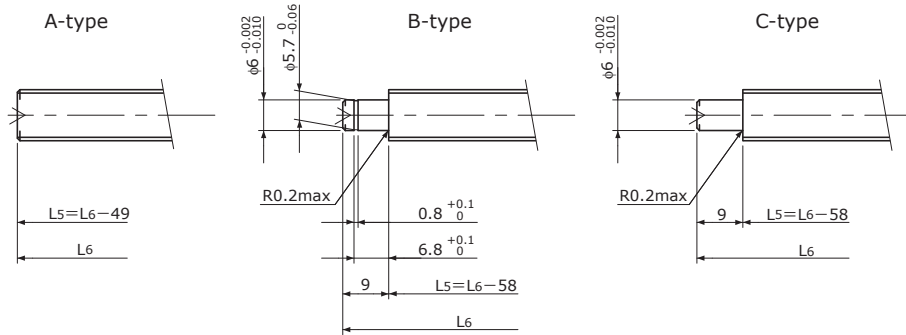

L5: Thread length after end-journal machining. 追加工后的螺纹部长度
L6: Total length after end-journal machining. 追加工后的总长

Support-unit Recommendation 推荐的支撑单元	Supported-side 支撑侧	Fixed-side 固定侧
	MSU-8CS/8GS, EF8	MSU-8C/8G, EK8

D-type: Other than the above. 上述以外的形状

Unit (单位): mm

Ball Screw Model 滚珠丝杠型号	Travel 行程	Shaft length 丝杠轴长度				Travel deviation 代表移动量误差 e_p	Total Run-out 全跳动 \nearrow	Axial play 轴向间隙	Basic Load Rating 基本额定负载 N	
		L ₁	L ₂	L ₃	L ₄				Dynamic 额定动负载 Ca	Static 额定静负载 Coa
PSRT1002K-201R250C5	175	201	205	213	250	± 0.023	0.055	~ 0.005	1450	3000

Note) Please refer to page A-321 for order code of end-journal machining. 注) 追加工的公称型号指定方法, 请参照A-321页