

# Precision Ball Screws 精密滚珠丝杠

## Single Nut with Flange 带法兰单螺母

## Backlash type/Preload type 齿侧间隙型/预压型

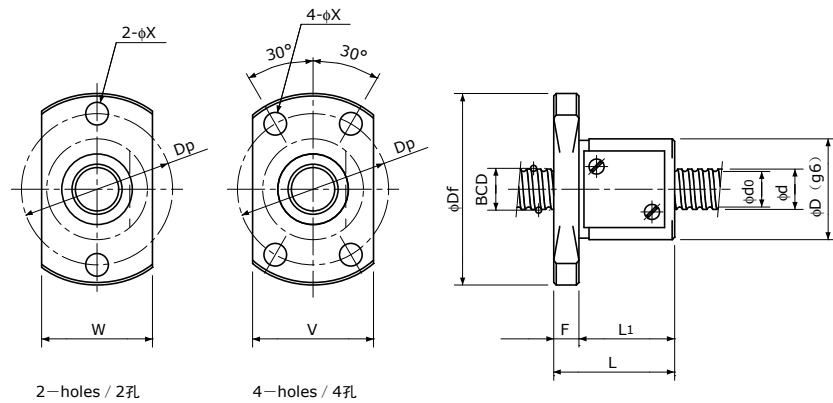

Type-1: Return-plate type  
复式回路板循环方式

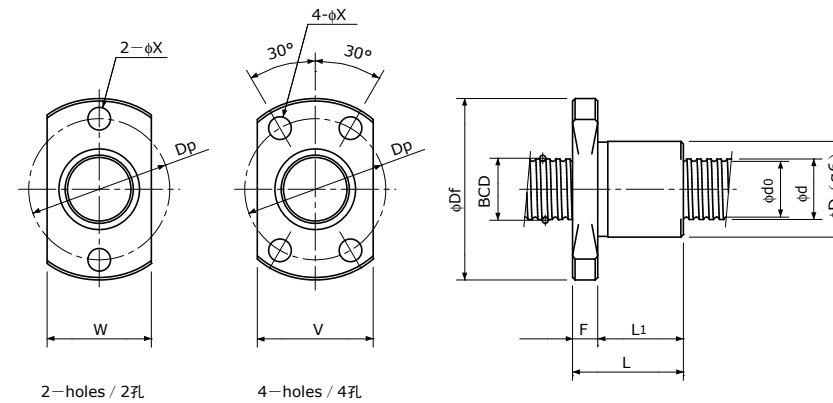

Type-2: Internal-deflector type or End-deflector type  
陀螺式循环方式或偏转器式循环方式

Unit (单位): mm

Ball Nut Model number 螺母型号	Shaft nominal dia. 丝杠轴公称外径 d	Lead 导程	Ball size 丝杠直径	BCD 钢珠中心直径	Lead angle 导程角	Root dia. 底径 d <sub>0</sub>	Number of Circuit 循环数	Basic Load Rating 基本额定负载 N		Nut Rigidity 螺母刚性 N/μm	Nut dimension 螺母尺寸									Ball Nut Model number 螺母型号	
								Dynamic 额定动负载 Ca	Static 额定静负载 Coa		Nut type 螺母类型	D	Df	L	L <sub>1</sub>	F	W	V	Dp		Bolt Hole 安装孔 X
FBS 0500.5 A	5	0.5	0.4	5.10	1°47'	4.6	2.7×1	180 / —	370 / —	44 / —	1	11	23	13	10	3	13	—	17	3.4	FBS 0500.5 A
FKB 0501 A	5	1	0.6	5.15	3°32'	4.4	1×3	330 / 330	560 / 560	45 / 70	2	10	20	13	10	3	12	14	15	2.9	FKB 0501 A
FBS 0501 B	5	1	0.8	5.15	3°32'	4.3	3.7×1	630 / 400	1000 / 500	65 / 55	1	12	24	17	13	4	14	15	18	3.4	FBS 0501 B
FBS 0504 A	5	4	0.8	5.15	13°53'	4.3	2.7×1	470 / 300	720 / 360	47 / 39	1	12	24	22	18	4	14	15	18	3.4	FBS 0504 A

- 注1) 设计时, 请注意使滚珠丝杠轴端的其中一端不超过丝杠轴底径。如果两个轴端设计得大于底径, 则将无法组装螺母。
- 注2) 标准螺母不带密封。需要密封时, 螺母的尺寸将发生变化, 详情请垂询本公司。某些型号的螺母不能安装密封, 敬请注意。
- 注3) 表中的刚性值为螺母的刚性值, 是在以下条件下, 根据轴向弹性位移量计算得出的理论值。齿侧间隙型: 相当于基本额定动负载Ca的30%的轴向负载作用时; 预压型: 施加了相当于基本额定动负载Ca的5%的预压时; 轴向负载及预压量与上述条件不同时, 可通过p-A823的公式计算。
- 注4) 标准螺纹旋向为右旋。需要左旋时, 请垂询本公司。
- 注5) 基本额定负载和刚性值(齿侧间隙型和预压型的刚性值可能会有不同)一并标示在上表中。

Basic Load Rating 基本额定负载 N		Nut Rigidity 螺母刚性 N/μm
Dynamic 额定动负载 Ca	Static 额定静负载 Coa	
1000 / 640	3300 / 1650	164 / 138

Preload type 预压型  
Backlash type 齿侧间隙型

- Note 1) The diameter of one of the Screw Shaft ends must be less than the Screw Shaft Root diameter, otherwise Ball Nut cannot be installed.
- Note 2) Ball Nut dimension is without seal at the both ends. If the seals are required, Ball Nut dimension should be changed, in that case, please ask KSS. Some type of Ball Nuts cannot equip with seals, please ask KSS representative.
- Note 3) The Rigidity values shown in the table are theoretical values of Ball Nut Rigidity calculated from the amount of Elastic Displacement under the following conditions. Backlash type; Apply the Axial load equivalent to 30% of the Basic Dynamic Load Rating Ca. Preload type; Apply the Preload equivalent to 5% of the Basic Dynamic Load Rating Ca. For Axial load or Preload condition other than the above, see the formula in p-A823, you can calculate Rigidity using this formula.
- Note 4) All models are Right-hand Screw. If Left-hand Screw is required, please ask KSS representative.
- Note 5) Basic Load Rating and Rigidity for Backlash type and Preload type are described in the same cell.