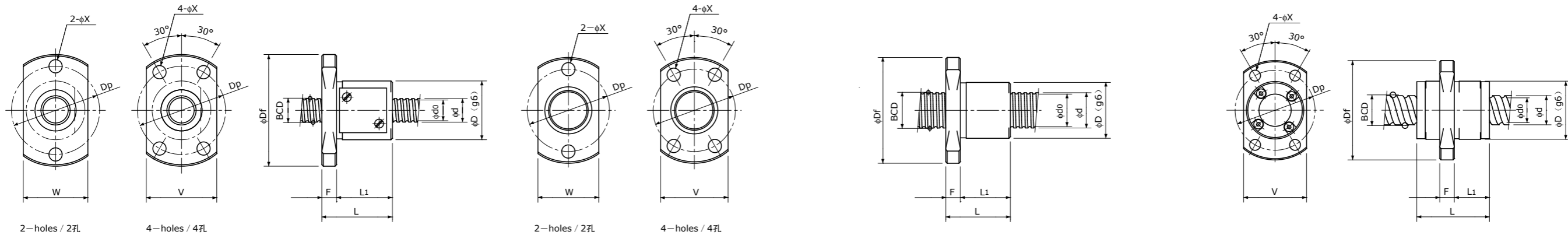

Precision Ball Screws 精密滚珠丝杠

Single Nut with Flange
带法兰单螺母Backlash type/Preload type
齿侧间隙型/预压型Type-1:Return-plate type
复式回路板循环方式Type-2:Internal-deflector type or
End-deflector type
陀螺式循环方式或偏转器式循环方式Type-3:End-cap type or End-deflector type
端盖循环方式或偏转器式循环方式

Unit (单位): mm

Ball Nut Model number 螺母型号	Shaft nominal dia. 丝杠轴公称外径 d	Lead 导程	Ball size 丝杠直径	BCD 钢珠中心直径	Lead angle 导程角	Root dia. 底径 d ₀	Number of Circuit 循环数	Basic Load Rating 基本额定负载 N		Nut Rigidity 螺母刚性 N/μm	Nut dimension 螺母尺寸									Ball Nut Model number 螺母型号	
								Dynamic 额定动负载 Ca	Static 额定静负载 Coa		Nut type 螺母类型	D	Df	L	L ₁	F	W	V	Dp		Bolt Hole 安装孔 X
FDB 0802.5 A	8	2.5	1.5875	8.00	5°41'	6.3	2.7×1	1850 / —	3000 / —	80 / —	2	16	29	16	12	4	—	18	23	3.4	FDB 0802.5 A
FBS 0802.5 B	8	2.5	1.5875	8.30	5°29'	6.6	3.7×1	2400 / 1550	4100 / 2100	111 / 93	1	20	38	26	21	5	22	23	30	4.5	FBS 0802.5 B
FBS 0803 A	8	3	2.0	8.30	6°34'	6.2	2.7×1	2600 / 1650	4200 / 2100	85 / 70	1	20	38	25	20	5	22	23	30	4.5	FBS 0803 A
FBS 0804 A	8	4	2.0	8.30	8°43'	6.2	2.7×1	2600 / 1650	4200 / 2100	84 / 70	1	21	39	28	23	5	23	23	31	4.5	FBS 0804 A
FBS 0805 A	8	5	1.5875	8.30	10°51'	6.6	2.7×1	1850 / 1150	3000 / 1500	82 / 67	1	18	31	28	24	4	20	20	25	3.4	FBS 0805 A
FEB 0808 A	8	8	1.5875	8.40	16°52'	6.7	1.6×2	2200 / —	3800 / —	95 / —	3	18	31	20	10	4	—	20	25	3.4	FEB 0808 A
FEB 0810 A	8	10	1.5875	8.40	20°45'	6.7	1.6×2	2200 / —	3900 / —	92 / —	3	18	31	24	13	4	—	20	25	3.4	FEB 0810 A
FEB 0812 A	8	12	1.5875	8.40	24°27'	6.7	1.6×2	2200 / —	4000 / —	90 / —	3	18	31	27	17	4	—	20	25	3.4	FEB 0812 A

注1) 设计时, 请注意使滚珠丝杠轴端的其中一端不超过丝杠轴底径。
如果两个轴端设计得大于底径, 则将无法组装螺母。

注2) 标准螺母不带密封。
需要密封时, 螺母的尺寸将发生变化, 详情请垂询本公司。
某些型号的螺母不能安装密封, 敬请注意。

注3) 表中的刚性值为螺母的刚性值, 是在以下条件下, 根据轴向弹性位移量计算得出的理论值。
齿侧间隙型: 相当于基本额定动负载Ca的30%的轴向负载作用时
预压型: 施加了相当于基本额定动负载Ca的5%的预压时
轴向负载及预压量与上述条件不同时, 可通过p-A823的公式计算。

注4) 标准螺纹旋向为右旋。
需要左旋时, 请垂询本公司。

注5) 基本额定负载和刚性值(齿侧间隙型和预压型的刚性值可能会有不同)一并标示在上表中。

Basic Load Rating 基本额定负载 N		Nut Rigidity 螺母刚性 N/μm
Dynamic 额定动负载 Ca	Static 额定静负载 Coa	
1000 / 640	3300 / 1650	164 / 138

Preload type
预压型
Backlash type
齿侧间隙型

Note 1) The diameter of one of the Screw Shaft ends must be less than the Screw Shaft Root diameter, otherwise Ball Nut cannot be installed.

Note 2) Ball Nut dimension is without seal at the both ends.
If the seals are required, Ball Nut dimension should be changed, in that case, please ask KSS.
Some type of Ball Nuts cannot equip with seals, please ask KSS representative.

Note 3) The Rigidity values shown in the table are theoretical values of Ball Nut Rigidity calculated from the amount of Elastic Displacement under the following conditions.
Backlash type ; Apply the Axial load equivalent to 30% of the Basic Dynamic Load Rating Ca.
Preload type ; Apply the Preload equivalent to 5% of the Basic Dynamic Load Rating Ca.
For Axial load or Preload condition other than the above, see the formula in p-A823, you can calculate Rigidity using this formula.

Note 4) All models are Right-hand Screw. If Left-hand Screw is required, please ask KSS representative.

Note 5) Basic Load Rating and Rigidity for Backlash type and Preload type are described in the same cell.