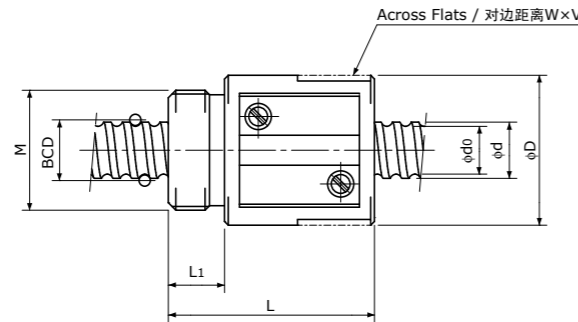
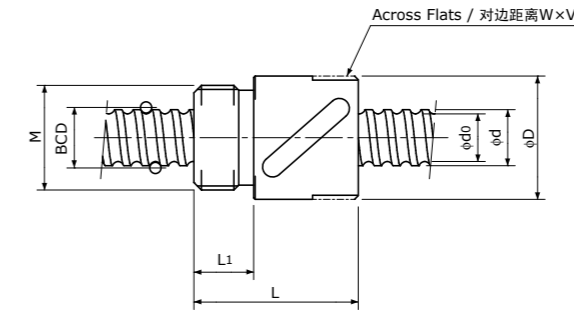

Precision Ball Screws 精密滚珠丝杠

Single Nut with M-thread
带公制螺纹单螺母Backlash type/Preload type
齿侧间隙型/预压型Type-1: Return-plate type
复式回路板循环方式Type-2: Return-tube type
回路管循环方式

Unit (单位): mm

Ball Nut Model number 螺母型号	Shaft nominal dia. 丝杠轴公称外径 d	Lead 导程	Ball size 丝杠直径	BCD 钢珠中心直径	Lead angle 导程角	Root dia. 底径 d ₀	Number of Circuit 循环数	Basic Load Rating 基本额定负载 N		Nut Rigidity 螺母刚性 N/∑m	Nut dimension 螺母尺寸					Ball Nut Model number 螺母型号		
								Dynamic 额定动负载 C _a	Static 额定静负载 C _{0a}		Nut type 螺母类型	D	L	L ₁	Across Flats width 对边距离 W		Across Flats length 对边距离长度 V	M
MS 1002 B	10	2	1.5875	10.30	3°32'	8.6	3.7×1	2700 / 1750	5300 / 2700	134 / 112	1	23	27.5	7.5	21	5	M17×1.0	MS 1002 B
MS 1202 B	12	2	1.5875	12.30	2°58'	10.6	3.7×1	3000 / 1900	6400 / 3200	156 / 132	1	25	30	10	23	5	M20×1.0	MS 1202 B
MS 1204 T	12	4	2.381	12.30	5°55'	9.8	2.5×1	3900 / —	7000 / —	113 / —	2	25.5	34	10	23	5	M20×1.0	MS 1204 T
MS 1402 B	14	2	1.5875	14.30	2°33'	12.6	3.7×1	3200 / 2000	7500 / 3800	176 / 148	1	26	30	10	23	5	M22×1.5	MS 1402 B
MS 1404 B	14	4	2.381	14.30	5°05'	11.8	3.7×1	5700 / 3600	11600 / 5800	187 / 157	1	30	38	10	27	8	M25×1.0	MS 1404 B

注1) 设计时, 请注意使滚珠丝杠轴端的其中一端不超过丝杠轴底径。

如果两个轴端设计得大于底径, 则将无法组装螺母。

注2) 标准螺母不带密封。不能安装密封, 敬请注意。

注3) 表中的刚性值为螺母的刚性值, 是在以下条件下, 根据轴向弹性位移量计算得出的理论值。

齿侧间隙型: 相当于基本额定动负载Ca的30%的轴向负载作用时

预压型: 施加了相当于基本额定动负载Ca的5%的预压时

轴向负载及预压量与上述条件不同时, 可通过p-A823的公式计算。

注4) 标准螺纹旋向为右旋。

需要左旋时, 请垂询本公司。

注5) 为了便于安装配合零件而需要对螺母外径进行对边距离加工或开孔加工时,

请垂询本公司。

注6) 基本额定负载和刚性值(齿侧间隙型和预压型的刚性值可能会有不同)一并标示在上表中。

Basic Load Rating 基本额定负载 N		Nut Rigidity 螺母刚性 N/∑m
Dynamic 额定动负载 C _a	Static 额定静负载 C _{0a}	
1000 / 640	3300 / 1650	164 / 138
		Preload type 预压型
		Backlash type 齿侧间隙型

Note 1) The diameter of one of the Screw Shaft ends must be less than the Screw Shaft Root diameter, otherwise Ball Nut cannot be installed.

Note 2) Ball Nut dimension is without seal at the both ends. All type of Ball Nuts cannot equip with seals.

Note 3) The Rigidity values shown in the table are theoretical values of Ball Nut Rigidity calculated from the amount of Elastic Displacement under the following conditions.

Backlash type; Apply the Axial load equivalent to 30% of the Basic Dynamic Load Rating C_a.

Preload type; Apply the Preload equivalent to 5% of the Basic Dynamic Load Rating C_a.

For Axial load or Preload condition other than the above, see the formula in p-A823, you can calculate Rigidity using this formula.

Note 4) All models are Right-hand Screw. If Left-hand Screw is required, please ask KSS representative.

Note 5) Across Flats or drill hole is available on the Ball Nut for the convenience of assembly. Please ask KSS representative.

Note 6) Basic Load Rating and Rigidity for Backlash type and Preload type are described in the same cell.