

Rolled Ball Screws 冷轧滚珠丝杠

Single Nut with Flange 带法兰单螺母

Backlash type
齿侧间隙型

- 也可生产对轴端直径进行了加粗设计的台阶型冷轧加工（下图），详情请垂询本公司。（轴端直径 $\phi 12$ 以下）
- Rolled Ball Screws with integrated journal are available ($\phi 12$ or less only), which have larger diameter than threaded area shown below.

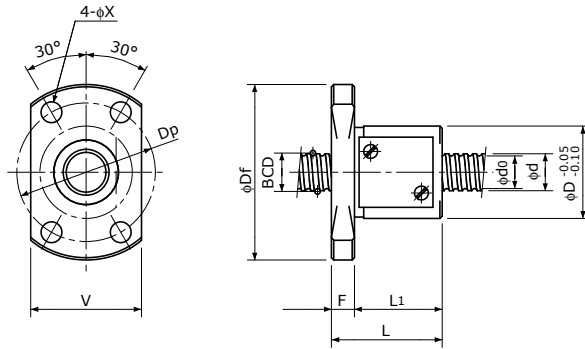
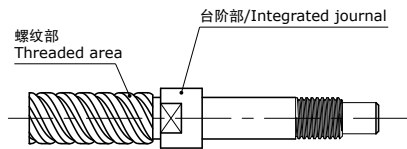

Type-1: Return-plate type
复式回路板循环方式

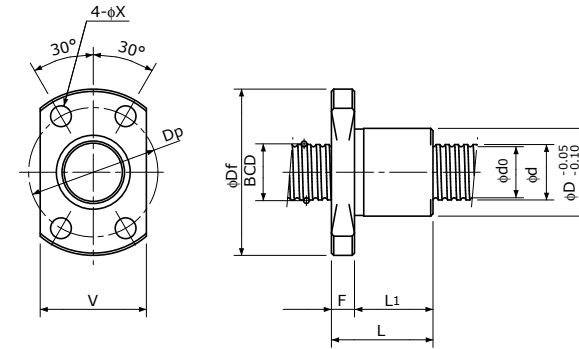

Type-2: End-deflector type
偏转器式循环方式

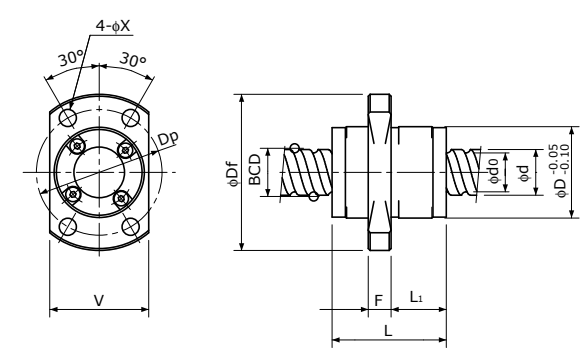

Type-3: End-cap type or End-deflector type
端盖循环方式或偏转器式循环方式

Unit (单位): mm

Ball Nut Model number 螺母型号	Shaft nominal dia. 丝杠轴公称外径 d	Lead 导程	Ball size 丝杠直径	BCD 钢珠中心直径	Lead angle 导程角	Root dia. 底径 d ₀	Number of Circuit 循环数	Basic Load Rating 基本额定负载 N		Nut Rigidity 螺母刚性 N/μm	Nut dimension 螺母尺寸									Ball Nut Model number 螺母型号	
								Dynamic 额定动负载 Ca	Static 额定静负载 Coa		Nut type 螺母类型	D	Df	L	L ₁	F	W	V	Dp		Bolt Hole 安装孔 X
MRB 0401	4	1	0.8	4.15	4° 23'	3.3	3.7×1	560	790	54	1	11	23	17	13	4	—	15	17	3.4	MRB 0401
MRB 0401K	4	1	0.6	4.15	4° 23'	3.4	1×3	300	430	38	2	9	19	13	10	3	—	13	14	2.9	MRB 0401K
MRB 0402	4	2	0.8	4.15	8° 43'	3.3	2.7×1	420	570	39	1	11	23	19	15	4	—	15	17	3.4	MRB 0402
MRB 0504	5	4	0.8	5.15	13° 53'	4.3	2.7×1	470	720	47	1	12	24	22	18	4	—	16	18	3.4	MRB 0504
MRB 0601**	6	1	0.8	6.15	2° 58'	5.3	3.7×1	680	1200	75	1	13	26	17	13	4	—	16	20	3.4	MRB 0601**
MRB 0601K	6	1	0.8	6.20	2° 56'	5.3	1×3	560	950	55	2	11	23	14.5	11	3.5	—	15	17	3.4	MRB 0601K
MRB 0602	6	2	1.0	6.20	5° 52'	5.1	2.7×1	750	1200	58	1	15	28	17	13	4	—	19	22	3.4	MRB 0602
MRB 0606	6	6	1.0	6.30	16° 52'	5.2	1.6×2	870	1450	67	3	14	27	17	8	4	—	16	21	3.4	MRB 0606
MRB 0610	6	10	1.2	6.30	26° 48'	5.0	1.2×2	950	1600	50	3	14	27	23	11.5	4	—	16	21	3.4	MRB 0610

- 注1) 标准螺纹旋向为右旋。
 注2) 设计时，由于生产及组装螺母的关系，请使滚珠丝杠的两个轴端不超过丝杠轴底径。需要单侧台阶型时，请垂询本公司。
 注3) 标准螺母不带密封。不能安装密封，敬请注意。
 注4) 刚性
 表中的刚性值，是在相当于基本额定动负载Ca的30%的轴向负载作用时，根据轴向弹性位移量计算的理论值。轴向负载与上述条件不同时，可通过p-A823的公式计算。
 注5) 不锈钢冷轧滚珠丝杠
 螺母型号后带**者可提供不锈钢冷轧滚珠丝杠。

- Note 1) All models are Right-hand screw.
 Note 2) The diameter of the Screw Shaft both ends must be less than the Screw Shaft Root diameter, because of production and Nut assembly reason. If bigger end-journal than Shaft diameter is required, please consult KSS.
 Note 3) Ball Nut dimension is without seal at the both ends. All type of Ball Nuts cannot equip with seals.
 Note 4) Rigidity
 The Rigidity values shown in the table are theoretical values calculated from the amount of Elastic Displacement under the Axial load equivalent to 30% of the Basic Dynamic Load Rating Ca.
 For Axial load condition other than the above, see the formula in p-A823, you can calculate Rigidity using this formula.
 Note 5) Stainless Rolled Ball Screw
 Stainless Rolled Ball Screw is available for Ball Nut Model Number marked **.