

BSSP0610

Shaft dia.(轴径)f6 Lead(导程)10mm

C5

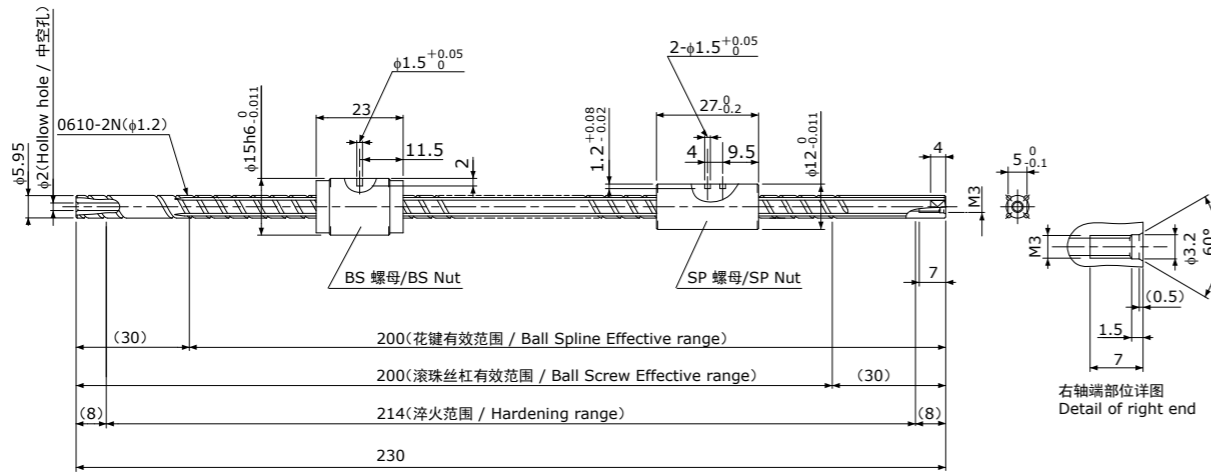

BSSP0810

Shaft dia.(轴径)f8 Lead(导程)10mm

C5

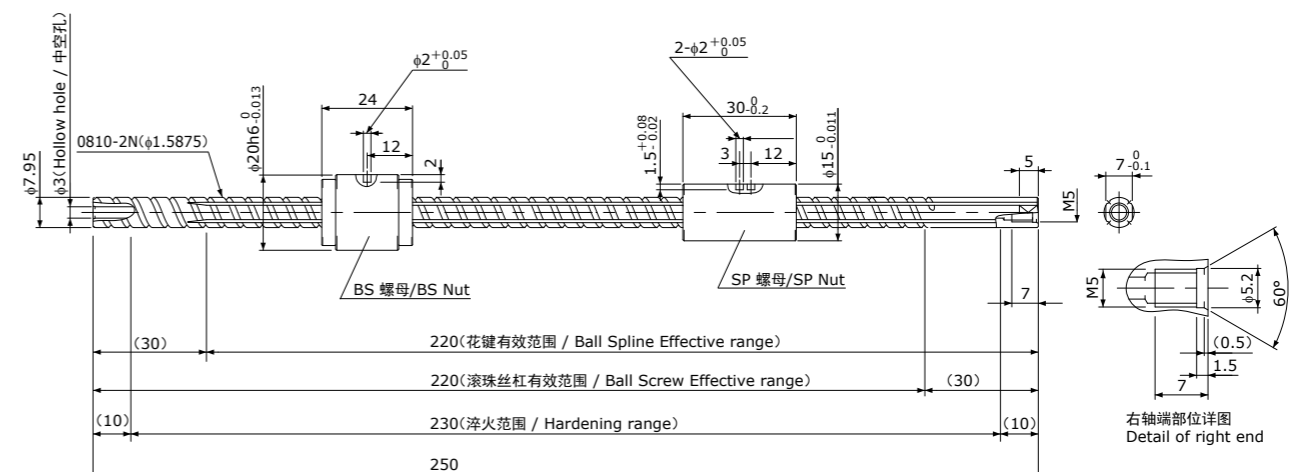

Ball Screw Specifications 滚珠丝杠主要技术参数	
Accuracy Grade 精度等级	JIS C5
Ball size 钢珠直径	f1.2mm
Number of thread 螺纹条数	2
Thread direction 螺纹旋向	Right 右
Pitch circle dia. 节圆直径	6.30mm
Number of circuit 循环数	1.2×2
Dynamic Basic Load Rating 基本额定动负载 Ca	(650N)
Static Basic Load Rating 基本额定静负载 Coa	(900N)
Axial Play 轴向间隙	Max 0.005 mm

Ball Spline Specifications 滚珠花键主要技术参数	
Accuracy Grade 精度等级	JIS C5
Dynamic Basic Load Rating 基本额定动负载 Cr	(750N)
Static Basic Load Rating 基本额定静负载 Cor	(1200N)
Dynamic Basic Torque Rating 基本额定动扭矩 Ct	(1.9 Nm)
Static Basic Torque Rating 基本额定静扭矩 Cot	(1.3 Nm)
Radial Play 径向间隙	Max 0.002 mm

Common Specifications 通用技术参数		
Material 材质	Shaft 轴	SUJ2
	Nut 螺母	SCM415
Anti-rust treatment 防锈处理	Anti-rust Oil 防锈油	

Note 1) The detail will be provided by drawing.
Note 2) Female thread on left end journal is not available.
注1) 详情记载于规格图中。
注2) 不进行轴端内螺纹的追加加工。

【轴端追加加工/Re-works on Shaft-end】

Other parts can be attached by re-working the end journal, such as turning down, or male thread.

通过对轴端进行切断及追加加工(车削、外螺纹加工), 使得部件得以安装。

轴端追加加工例 / Re-works Example

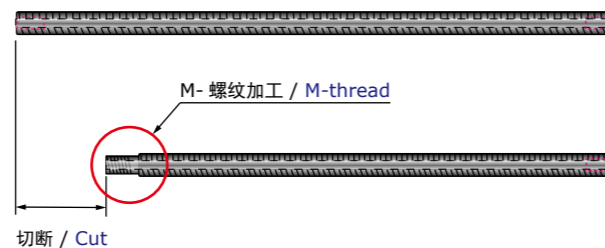

Ball Screw Specifications 滚珠丝杠主要技术参数	
Accuracy Grade 精度等级	JIS C5
Ball size 钢珠直径	f1.5875mm
Number of thread 螺纹条数	2
Thread direction 螺纹旋向	Right 右
Pitch circle dia. 节圆直径	8.40mm
Number of circuit 循环数	1.65×2
Dynamic Basic Load Rating 基本额定动负载 Ca	(1400N)
Static Basic Load Rating 基本额定静负载 Coa	(2000N)
Axial Play 轴向间隙	Max 0.005 mm

Ball Spline Specifications 滚珠花键主要技术参数	
Accuracy Grade 精度等级	JIS C5
Dynamic Basic Load Rating 基本额定动负载 Cr	(1000N)
Static Basic Load Rating 基本额定静负载 Cor	(1450N)
Dynamic Basic Torque Rating 基本额定动扭矩 Ct	(3.4Nm)
Static Basic Torque Rating 基本额定静扭矩 Cot	(2.4Nm)
Radial Play 径向间隙	Max 0.002 mm

Common Specifications 通用技术参数		
Material 材质	Shaft 轴	SUJ2
	Nut 螺母	SCM415
Anti-rust treatment 防锈处理	Anti-rust Oil 防锈油	

Note 1) The detail will be provided by drawing.
Note 2) Female thread on left end journal is not available.
注1) 详情记载于规格图中。
注2) 不进行轴端内螺纹的追加加工。

【轴端追加加工/Re-works on Shaft-end】

Other parts can be attached by re-working the end journal, such as turning down, or male thread.

通过对轴端进行切断及追加加工(车削、外螺纹加工), 使得部件得以安装。

轴端追加加工例 / Re-works Example

