

CREATIVE MOTION SYSTEMS

# SUPER DRIVE

Ultra Miniature Actuator Series  
Vol.37

KUMI, KUMIKO, KUMINA, KUMIRI,  
KUMIKO-FSCR, KUMINA-FSCR, KUMICON,  
KUMI-ML, KUMIKO-ML



**kss** CO.,LTD.

# The Age of Downsizing

## From the World Leading Producer of Miniature Ball Screws Comes The Brand New Ultra Miniature Actuator Series !!

In constant pursuit of the micro world, **kss** introduces unit products to respond to the wants of our customers.

**kss** has taken its motto of easy-to-use, secure ball screw and of environmental products to realize these units. The sliding characteristics brought to life by the merits of the miniature ball screw producer are backed by a reliability that has no equal.

In response to our customers' various wants, **kss** promotes the development of this ultra miniature actuator. Thank you for your continual support.



# Contents

## Standard Ultra Miniature Actuator Series

■ <b>KUMI</b> Series .....	4 - 5	
■ <b>KUMIKO</b> Series .....	6 - 7	
■ <b>KUMINA</b> Series .....	8 - 9	
■ <b>KUMIRI</b> Series (Specification change) .....	10 - 11	
■ <b>NEW</b> <b>KUMIKO-FSCR KUMINA-FSCR</b> Series .....	12 - 13	
■ <b>KUMICON</b> Series .....	14 - 15	
Accessories for KUMI, KUMIKO, KUMINA, KUMIRI, and KUMICON .....	15	
When using KUMI, KUMIKO, KUMINA, KUMIRI Series alone		
■ Driver KR-5M-SS .....	16 - 17	
■ Driver KR-55ME-SS .....	18 - 19	

## New Ultra Miniature Actuator Series

■ <b>NEW</b> <b>KUMI-ML KUMIKO-ML</b> Series .....	20 - 21	
■ <b>NEW</b> <b>KUMI-ML KUMIKO-ML</b> Accessories .....	22 - 24	
■ Ultra Miniature Actuator Special Products .....	25	

■ Safety Precautions for Using the Ultra Miniature Actuator .....	26
■ About <b>kss</b> .....	27

General purpose, easy-to-use devices capable of operating at high speeds



KUMI Series

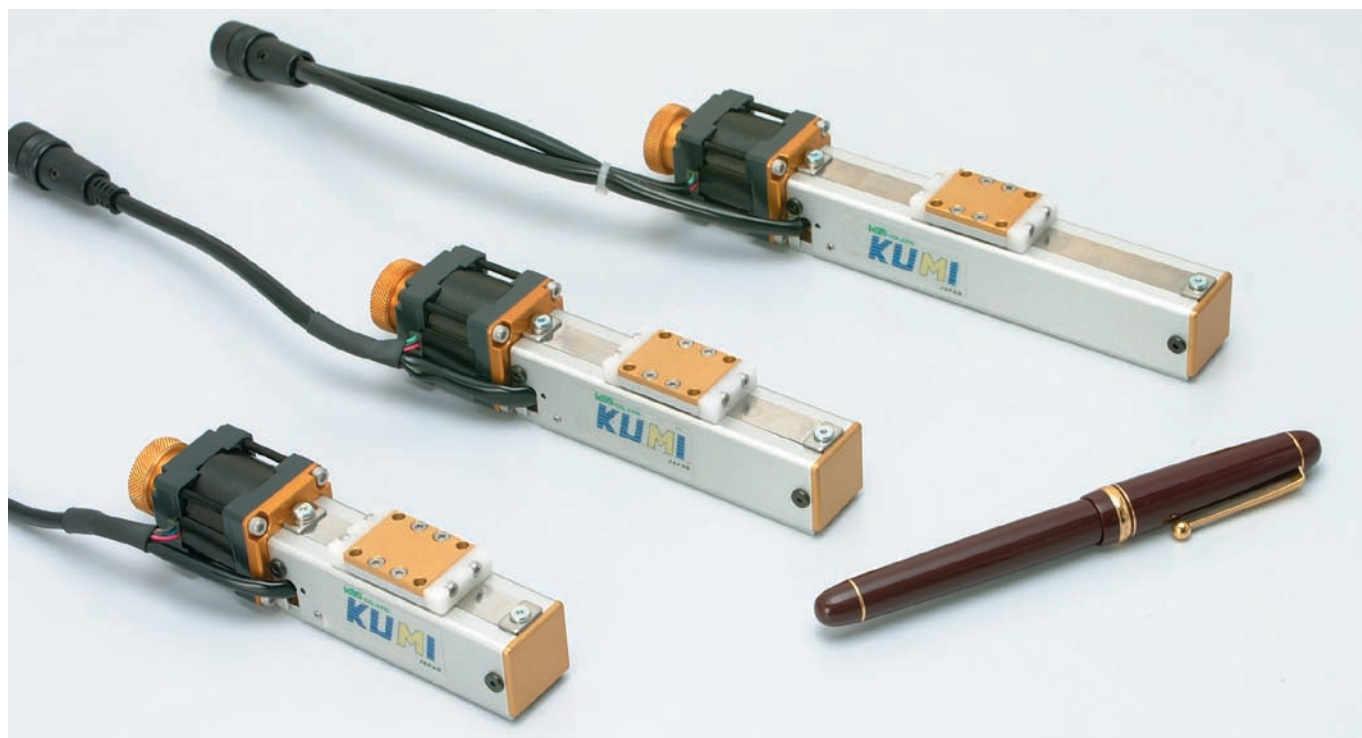

## Features

- Super-slim miniature actuators, up to 24 mm wide and 30 mm high (palm-sized).
- Low-friction resin lead screws (resin nuts) are used, resulting in low operating noise.
- Five-phase stepping motors are used, for smooth movement with minimal heat generation.
- Lightweight design makes these units ideal for vertical mounting.

## Specifications (Standard products)

Model	Units	KUMI-10-28	KUMI-30-28	KUMI-60-28
Stroke	(mm)	10	30	60
Repeated positioning accuracy	(mm)	± 0.03		
Maximum horizontal load capacity	N (kgf)	9.8 (1.0)		
Maximum vertical load capacity	N (kgf)	4.9 (0.5)		
Maximum load moment	N · m (kgf · cm)	Mp: 0.2 (2.0) My: 0.3 (2.9) Mr: 0.14 (1.4)		
Maximum speed	(mm/sec)	50	80	100
Initial lost motion	(mm)	0.1 max.		
Lead	(mm)	6		
Resolution	(mm/step)	0.012 (For full step)		
Weight	(kg)	0.2	0.23	0.25
Motor		Five-phase stepping motor, 0.35A /phase (28mm x 28mm)		
Sensor		Limit switch (mechanical, 1 point at motor side)		
Operating temperature range	(°C)	0 ~ 40		

\* Maximum load moments - Mp: Permissible moment in screw pitch direction; My: Permissible yaw moment; Mr: Permissible rolling moment

# Specifications diagram

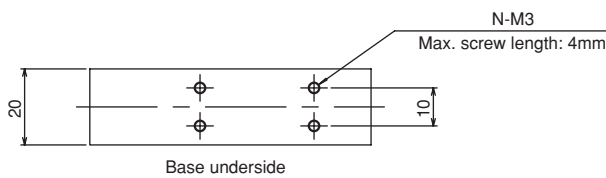
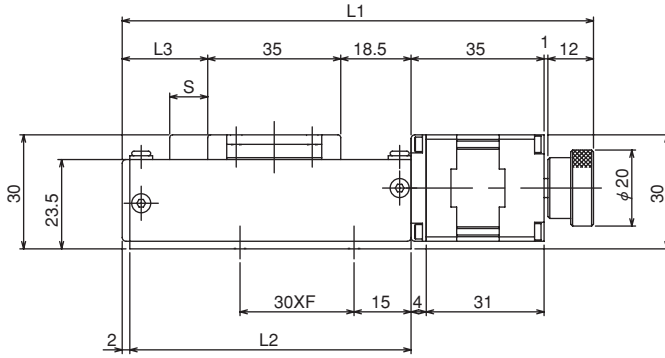
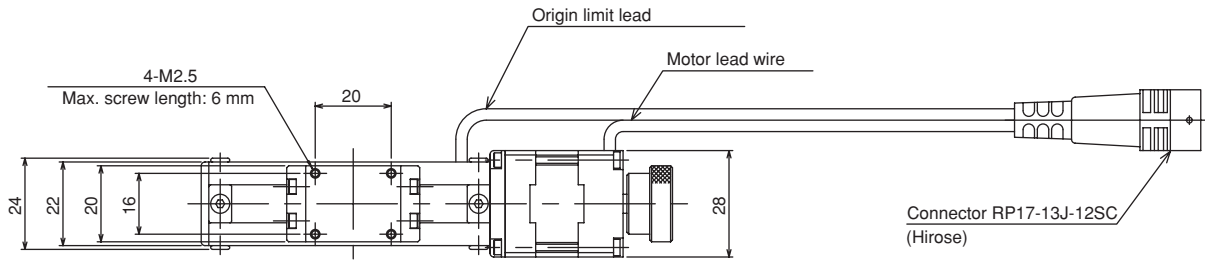

Model	L1	L2	L3	S	F	N
KUMI-10	124	74	22.5	10	1	4
KUMI-30	144	94	42.5	30	2	6
KUMI-60	174	124	72.5	60	3	8



## Applications

Ideal for reducing size of equipment such as small component installations, soldering robots, medical equipment controllers, and dispensers.

## Wire connection diagram

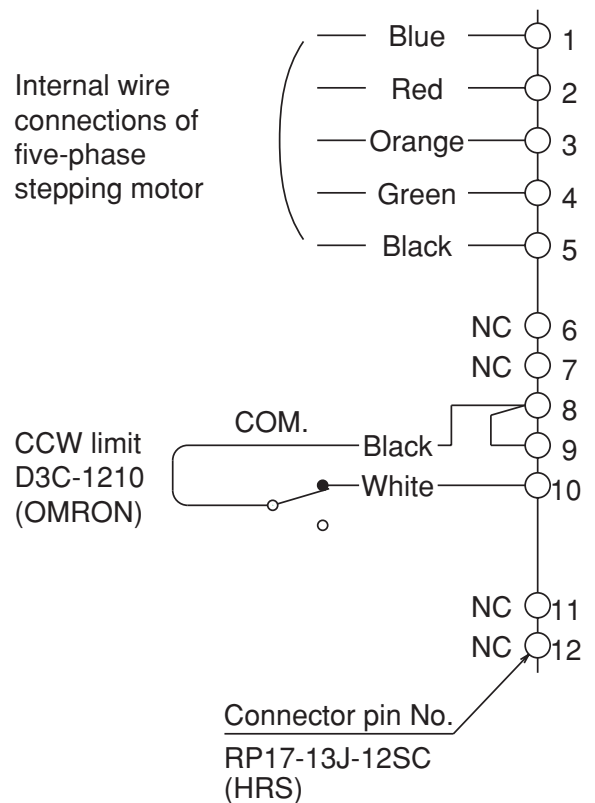

★ Special custom orders and single-unit orders are welcome.

High rigidity, accuracy, and durability

# KUMIKO

KUMIKO Series



## Features

- Super-slim miniature actuators, up to 26 mm wide and 37 mm high (palm-sized).
- Units featuring high rigidity, high accuracy, and high durability and using precision roll miniature ball screws and linear guides.
- Capable of high conveyor speeds, up to 120 mm/s.
- Five-phase stepping motors are used, enabling high resolution.
- Lightweight design makes these units ideal for vertical mounting.

## Specifications (Standard products)

Model	Units	KUMIKO-40-28	KUMIKO-60-28	KUMIKO-120-28
Stroke	(mm)	40	60	120
Repeated positioning accuracy	(mm)	± 0.01		
Maximum horizontal load capacity	N (kgf)	39.2 (4.0)		
Maximum vertical load capacity	N (kgf)	19.6 (2.0)		
Maximum load moment	N · m (kgf · cm)	Mp: 0.5 (5) My: 0.5 (5) Mr: 1.0 (10)		
Maximum speed	(mm/sec)	120		
Initial lost motion	(mm)	0.01 max.		
Lead	(mm)	4		
Resolution	(mm/step)	0.008 (For full step)		
Weight	(kg)	0.29	0.32	0.37
Motor		Five-phase stepping motor, 0.35 A/phase (28mm x 28mm)		
Sensor		Limit switch (mechanical, 1 point at motor side)		
Operating temperature range	(°C)	0 ~ 40		

\* Maximum load moments - Mp: Permissible moment in screw pitch direction; My: Permissible yaw moment; Mr: Permissible rolling moment

# Specifications diagram

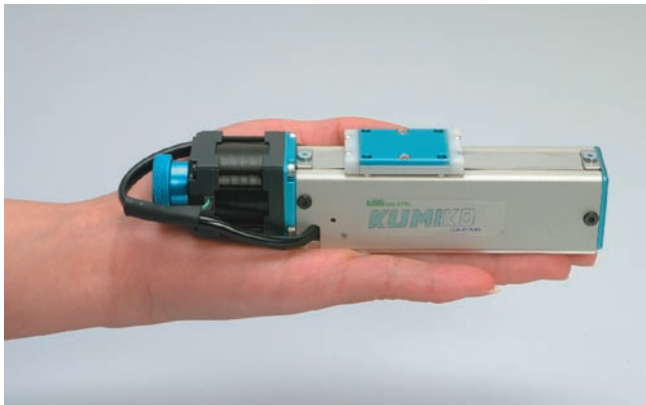
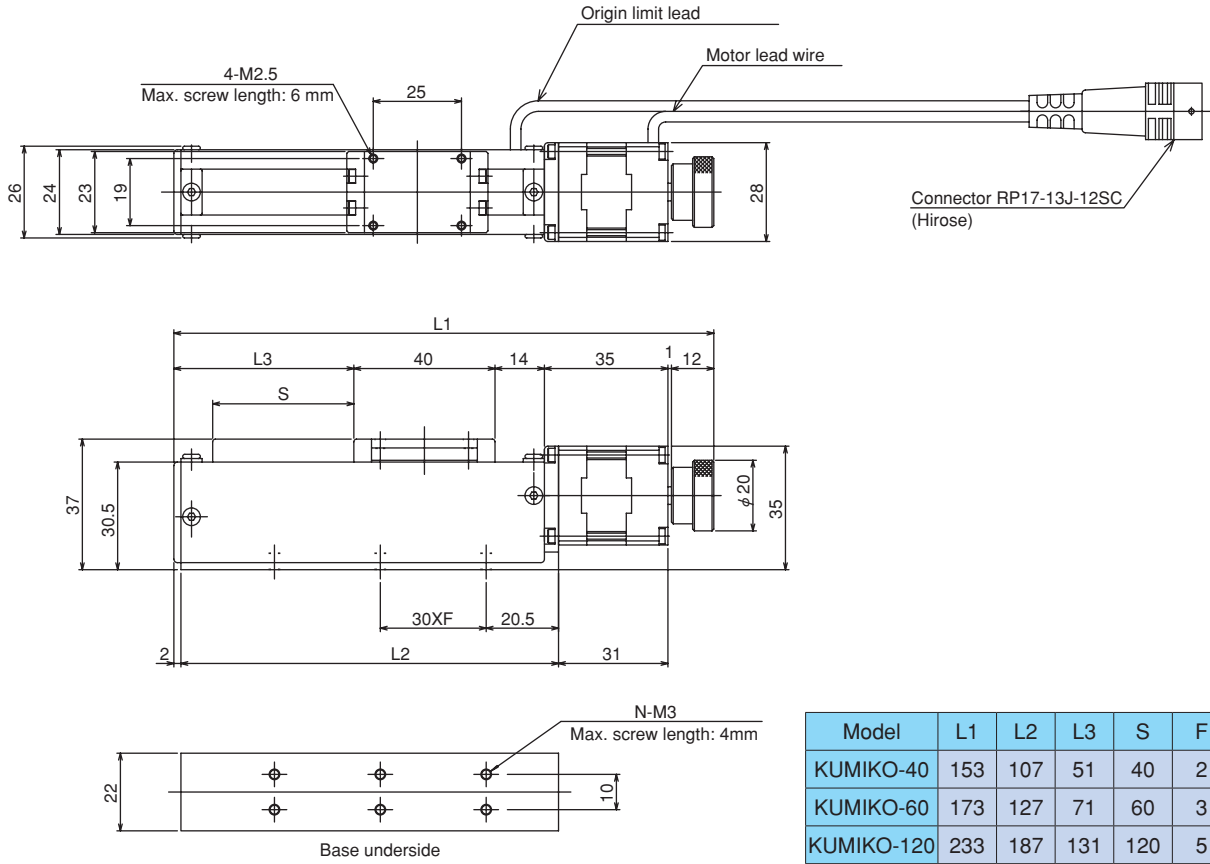

## Applications

Ideal for applications demanding high speed and durability, such as high-speed small components conveyor installations, dose control, and desktop robots.

## Wire connection diagram

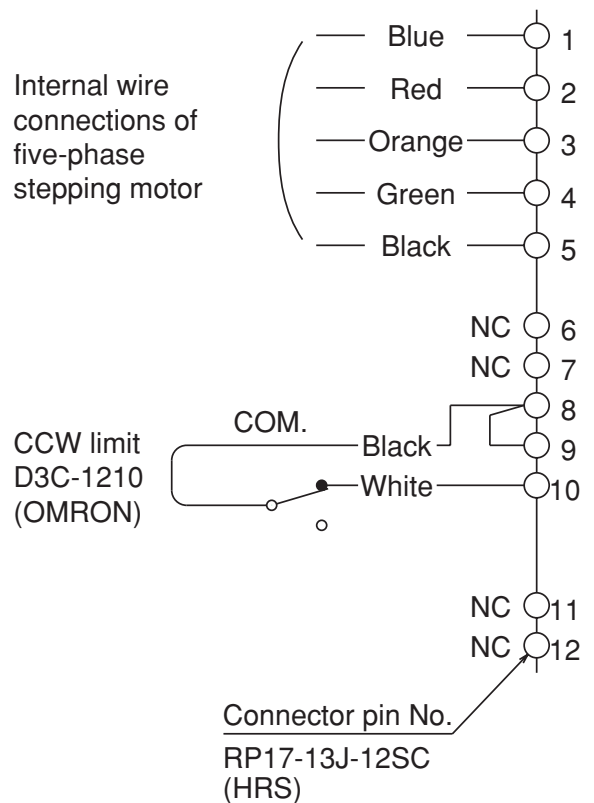

★ Special custom orders and single-unit orders are welcome.

Super slim units with refined precision

# KUMINA

KUMINA Series



## Features

- Super-slim miniature actuators, up to 24 mm wide and 30 mm high (palm-sized).
- Precision ground miniature ball screws are used, resulting in ultra-precision, high durability, and high resolution.
- These units incorporate photo sensors (CW / CCW), despite their ultra-compact size.
- Ideal for high-precision positioning of small components, and dose control.

## Specifications (Standard products)

Model	Units	KUMINA-20-24	KUMINA-30-24	KUMINA-60-24
Stroke	(mm)	20	30	60
Repeated positioning accuracy	(mm)	± 0.005		
Maximum horizontal load capacity	N (kgf)	29.4 (3.0)		
Maximum vertical load capacity	N (kgf)	10.2 (1.0)		
Maximum load moment	N · m (kgf · cm)	Mp: 0.6 (6.2) My: 0.6 (6.2) Mr: 1.17 (11.4)		
Maximum speed	(mm/sec)	20		
Initial lost motion	(mm)	0.005 max.		
Lead	(mm)	1		
Resolution	(mm/step)	0.002 (For full step)		
Weight	(kg)	0.2	0.21	0.23
Motor		Five-phase stepping motor, 0.35 A/phase (24mm x 24mm)		
Sensor		Photo micro sensor (2 points, motor side and opposite side): 5V DC, 50mA		
Operating temperature range	(°C)	0 ~ 40		

\* Maximum load moments - Mp: Permissible moment in screw pitch direction; My: Permissible yaw moment; Mr: Permissible rolling moment



# Specifications diagram

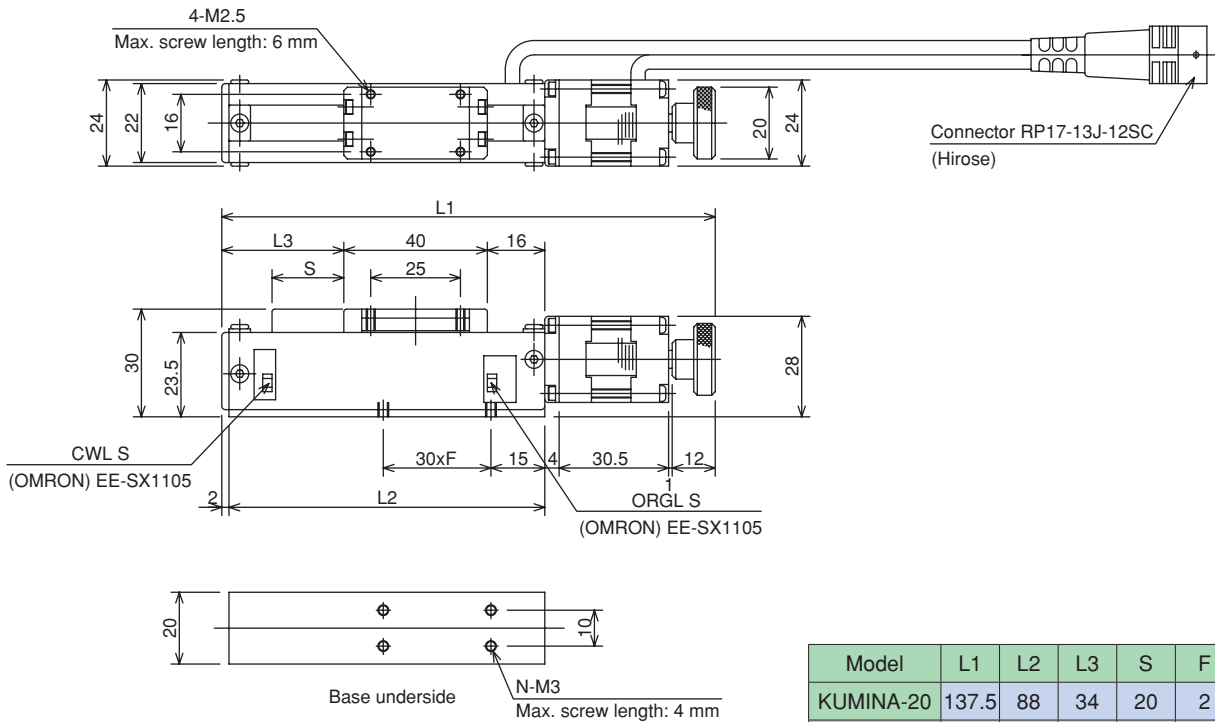

Model	L1	L2	L3	S	F	N
KUMINA-20	137.5	88	34	20	2	6
KUMINA-30	150.5	101	47	30	2	6
KUMINA-60	180.5	131	77	60	3	8

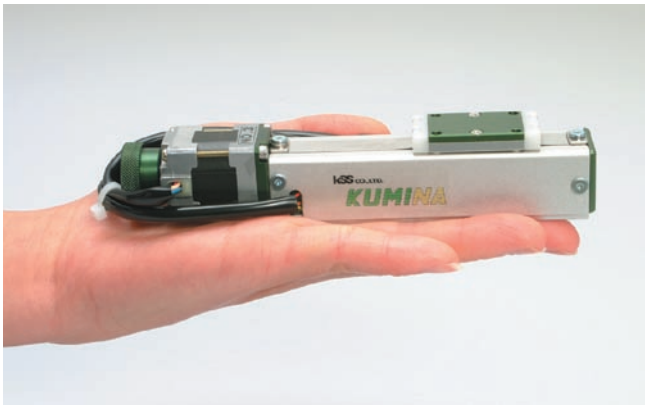

## Applications

Ideal for applications demanding high accuracy, such as precision positioning devices for small component installations, measuring equipment, desktop testing equipment, and precision dispensers.

## Wire connection diagram

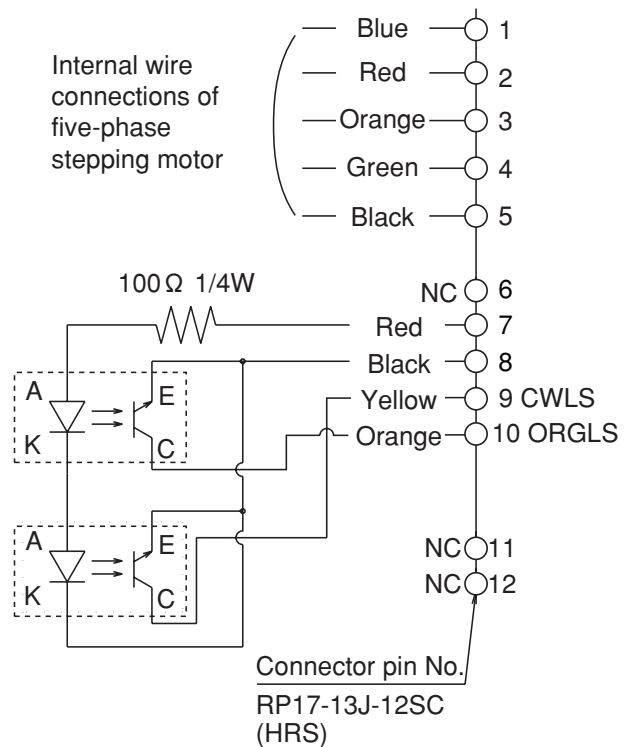

★ Special custom orders and single-unit orders are welcome.

## Miniature electrically powered cylinder for microscopic feeding



### KUMIRI Series



### Features

- Ultra-compact, small-stroke, rod-type actuator. (Palm-sized)
- Ideal for applications such as electrically powering micrometer heads.
- Precision ground ball screw or precision lead screws are used, resulting in high precision and high resolution.
- Even for such small size, A Built in photo sensor (CW, CCW) is at both ends
- Plastic parts are used, enabling low-cost construction. (KUMIRI-5)
- Metal parts and 0.5mm lead ball screw are used, resulting in high rigidity and ultra-precision. (KUMIRI-5SP)

### Specifications (Standard products)

Model	Units	KUMIRI-5	KUMIRI-5SP
Stroke	(mm)	10	
Repeated positioning accuracy	(mm)	± 0.005	± 0.002
Axial thrust	N (kgf)	29.4 (3.0)	29.4 (3.0)
Maximum speed	(mm/sec)	5	10
Drive system		Lead screw, M4, pitch : 0.5 mm	Precision ground ball screw, lead : 0.5 mm
Motor		Five-phase stepping motor, 0.35 A/phase (28 mm x 28 mm)	
Initial lost motion	(mm)	0.01max.	0.005max.
Resolution	(mm/step)	0.001 (For full step)	
Weight	(kg)	0.2	0.27
Sensor		Photo micro sensor (2 points, motor side and opposite side) : 5V DC, 50mA	
Operating temperature range	(°C)	0 ~ 40	

# Specifications diagram

## KUMIRI-5SP

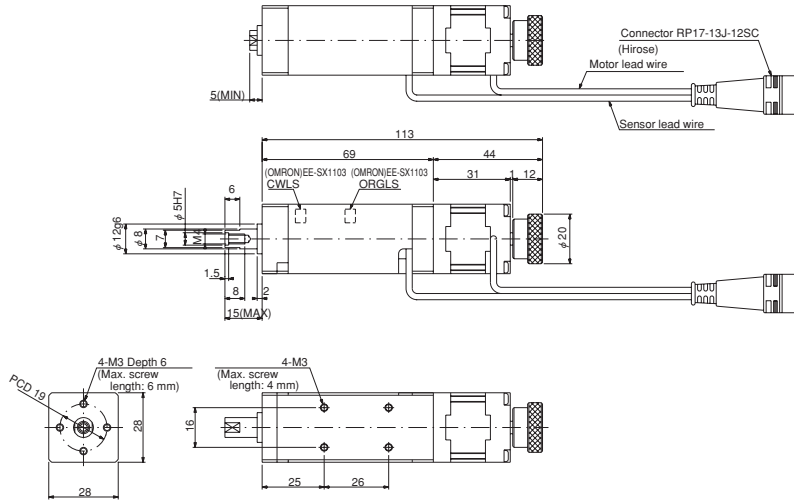

## KUMIRI-5

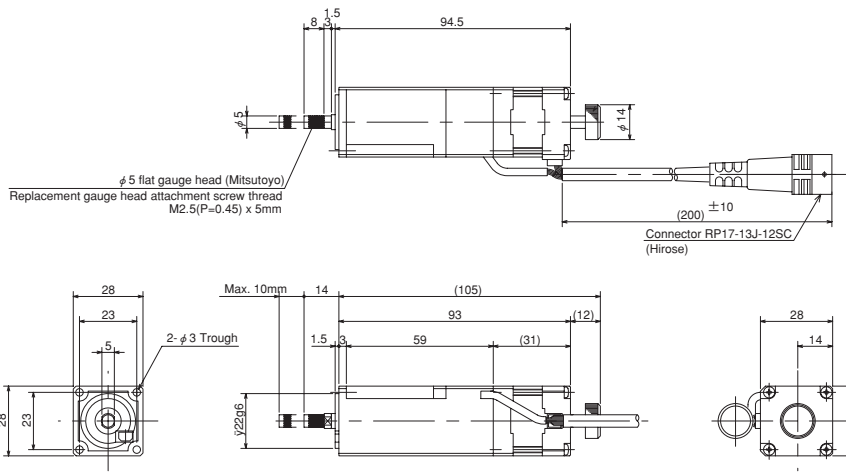

## Applications

Ideal for applications demanding smaller units and microscopic feeding, such as changing micrometer heads when manual stages are automated, fine angular adjustment, rotation control, precision dispensing, and mirror movement.

## Wire connection diagram

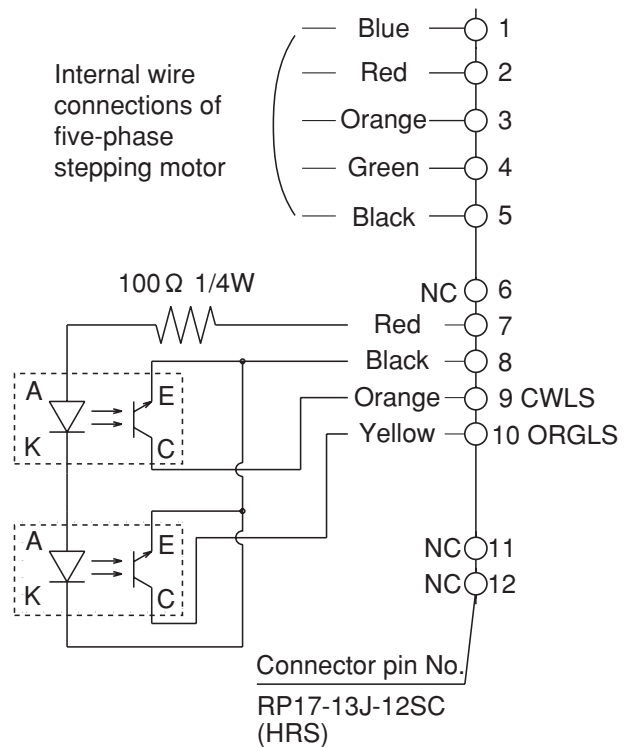

★ Special custom orders and single-unit orders are welcome.

## Anti-Static Ultra Miniature Actuator for Clean Room

# KUMIKO-FSCR KUMINA-FSCR

KUMIKO-FSCR  
KUMINA-FSCR  
Series

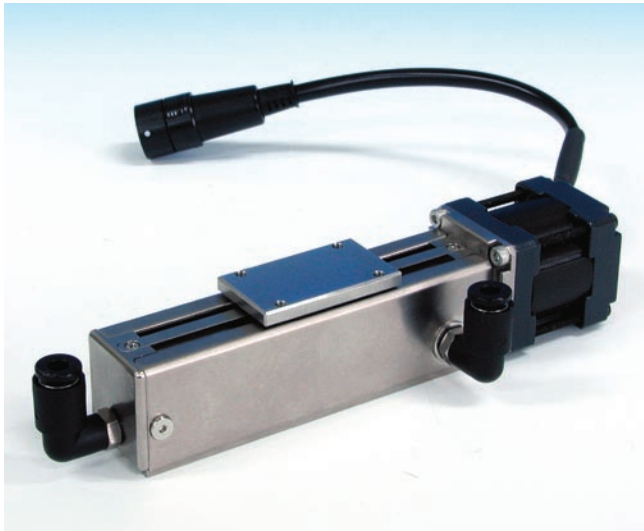

### Features

- Brand New Actuator is now released fit to clean room environment (Class 10, Tested) adding to our super Miniature Actuator Series.
- KSS own unique design to the Stainless steel cover and the Sliding part structure eliminates friction and the vacuum pipe joints prevent from dusting, in and out by absorption from inside.
- Aluminum & Non Electrolyzing Nickel Plating body of actuator to prevents from static problems.
- Even for such small size, A Built in photo sensor is at both ends.

### Model number notation

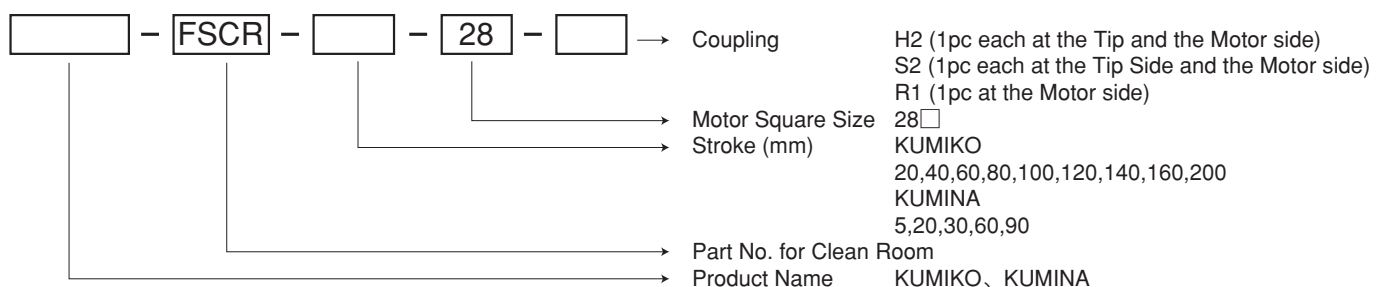

### Specifications (Ordered products)

Model	Units	KUMIKO-FSCR	KUMINA-FSCR
Stroke	(mm)	20,40,60,80,100,120,140,160,200	5,20,30,60,90
Repeated positioning accuracy	(mm)	± 0.01	± 0.005
Maximum horizontal load capacity	N (kgf)	39.2 (4.0)	29.4 (3.0)
Maximum vertical load capacity	N (kgf)	19.6 (2.0)	10.2 (1.0)
Maximum load moment	N · m (kgf · cm)	Mp: 0.5 (5) My: 0.5 (5) Mr: 1.0 (10)	Mp: 0.6 (6.2) My: 0.6 (6.2) Mr: 1.17 (11.4)
Maximum speed	(mm/sec)	120	20
Drive system		Precision rolled ball screw, Lead: 4mm	Precision ground ball screw, Lead: 1mm
Resolution	(mm/step)	0.008 (For full step)	0.002 (For full step)
Motor		Five-phase stepping motor, 0.35 A/phase (28mm x 28mm)	
Sensor		Photo micro sensor (2 points, motor side and opposite side) : 5V DC, 50mA	
Operating temperature range	(°C)	0 ~ 40	

\* Maximum load moments - Mp: Permissible moment in screw pitch direction; My: Permissible yaw moment; Mr: Permissible rolling moment

# Specifications diagram

## KUMIKO-FSCR

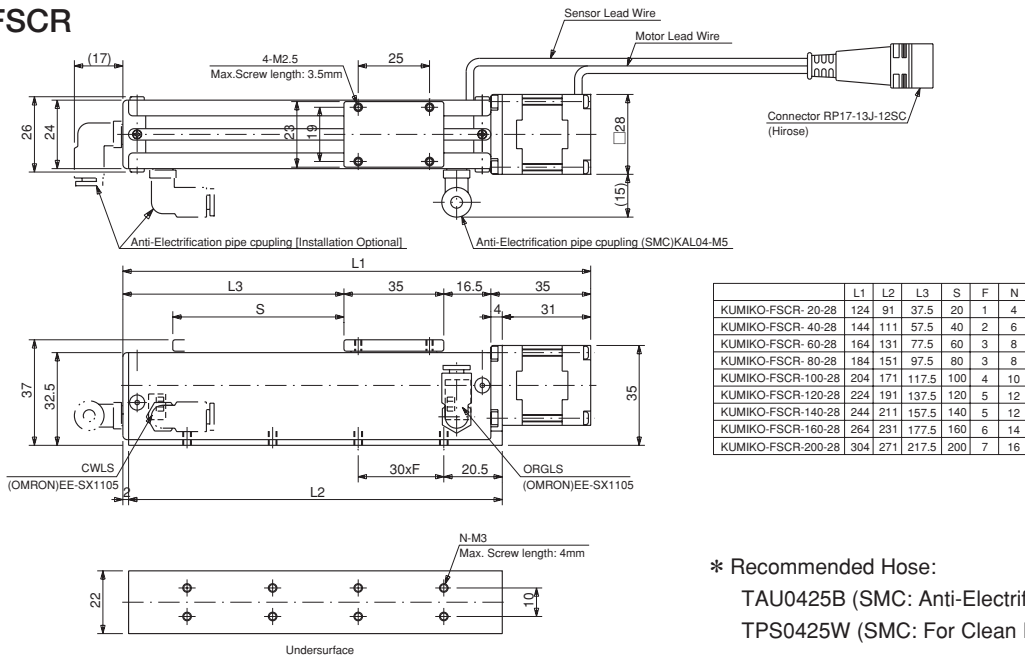

## KUMINA-FSCR

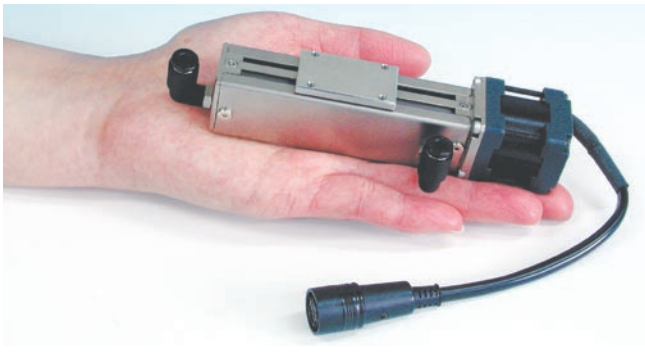
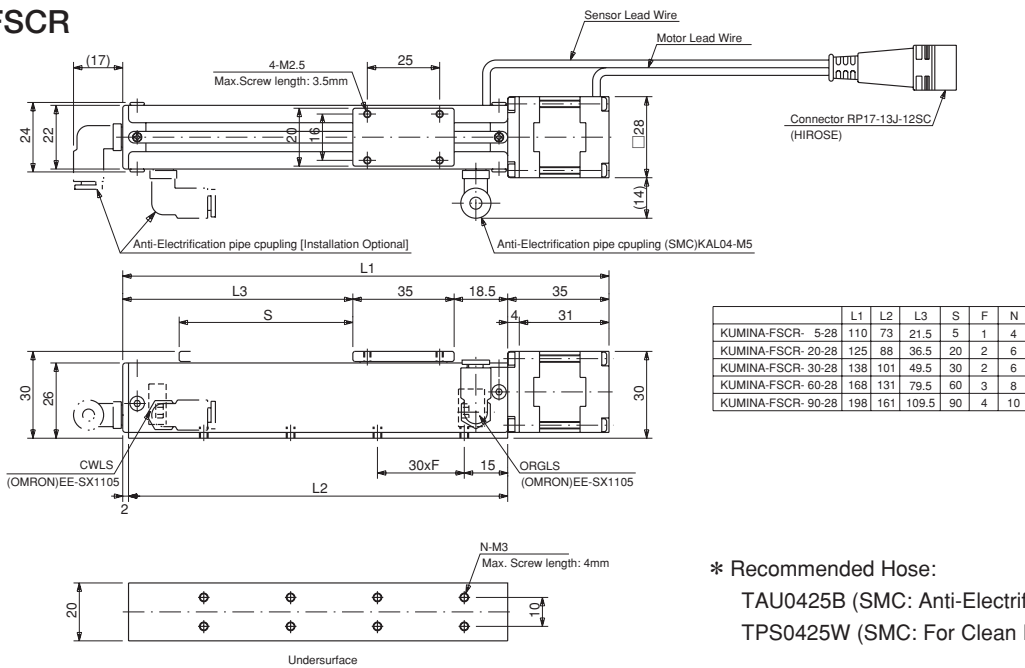

## Applications

It is the the best for the small part automatic assembly within clean room environment.

★ Special custom orders and single-unit orders are welcome.

## Wire connection diagram

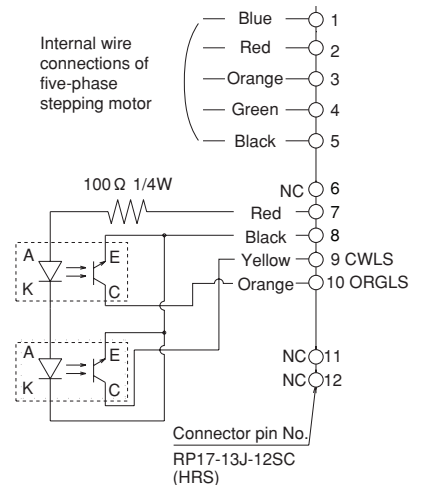

Custom-made controller, incorporating two-axis driver

# KUMICON

KUMICON Series



## Features

- Two-axis controller designed especially for the KUMI, KUMIKO, KUMINA, and KUMIRI-5 series.
- Incorporates a micro-step driver (with full-step and 1/5-step selection).
- Features an RS232C port to switch between manual or PC control.
- Simply connect to actuators to operate at 100 V AC.
- Software developed by KSS provides even greater ease-of-use.



KUMICON control software

## Specifications (Standard products)

Model		KUMIKON-2
Controller unit	Input power supply	AC100 ~ 240V 50 / 60Hz
	Operating environment temperature range	0 ~ 40°C
	Operating environment humidity range	20 ~ 85%PH
	Number of axis controlled	Two-axis control
	Set travel rate	999999999 Pulse
	Minimum drive frequency	1PPS
	Maximum drive frequency	20,000PPS
	Limit sensor	LS(+), LS(-) / Normal close
	DC power supply	Built-in photo sensor power supply: 5V DC, 50mA
	Interface	RS232C interface
Settings	1-axis/2-axis, PC / manual, full-step or 1/5-step Set when switching on by DIP switches	
Driver unit	Compatible motor	Five-phase stepping motor, 0.35A / phase
	Current reduction	Automatic

## Specifications diagram

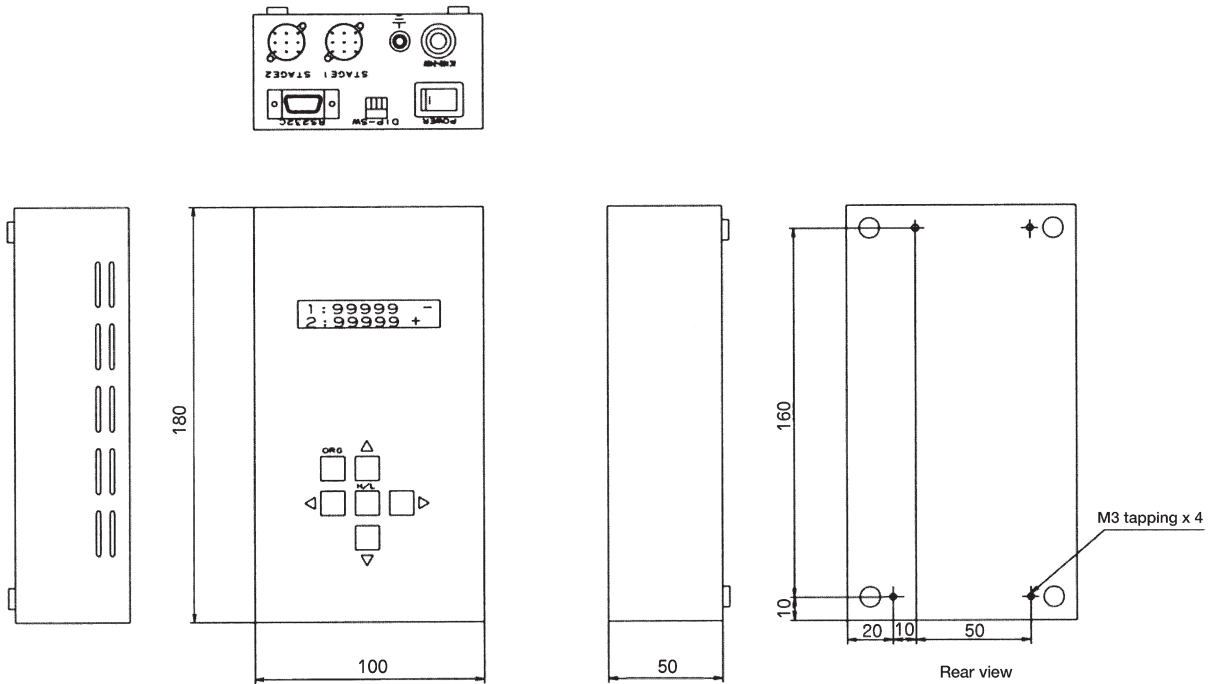

## Accessories for KUMI, KUMIKO, KUMINA, KUMIRI, and KUMICON (Option)

- Extension cable for connecting KUMI, KUMIKO, KUMINA, KUMIRI to KUMICON

### Model KK-2

Standard: 2 m, Special length: 1-5 m



- Extension cable for connecting KUMI, KUMIKO, KUMINA, KUMIRI to driver

### Model KD-2

Standard: 2 m, Special length: 1-5 m

\* With actuator connector at one end, bare cable at other end



- Solenoid brake unit for KUMI and KUMIKO

(manufactured to order)

Ideal for maintaining intermediate position when Z-axis power is off

\* Inquire for details.

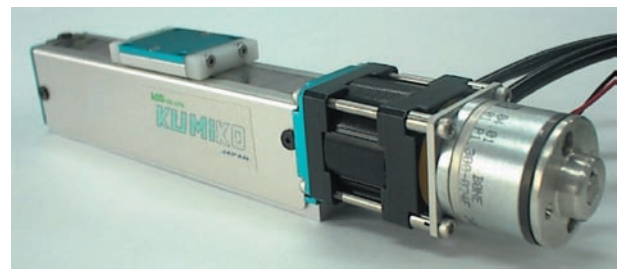

- Photograph sensor amplifier base

for KUMINA, KUMIKO-FSCR

Model SP-4021

It is required to use a sensor line power supply by DC24V.

Moreover, reversal of sensor logic is possible.

\* Inquire for details.

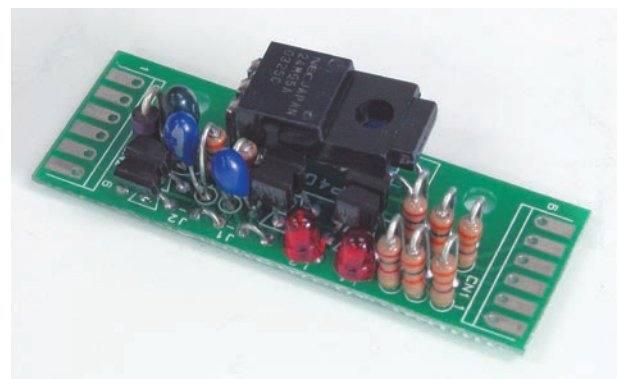

# Five-phase stepping motor driver

# KR-5M-SS

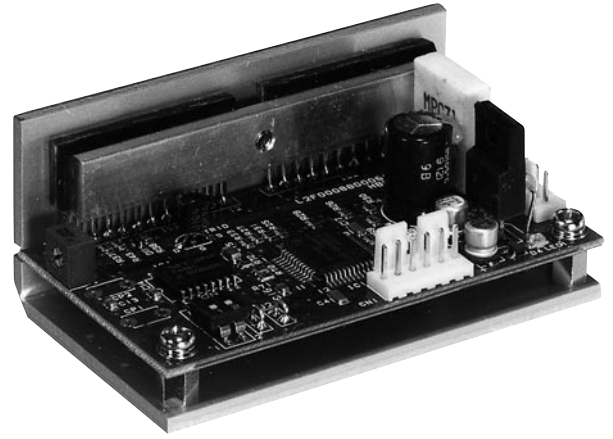

## Features

- Driver for five-phase stepping motor using a single 24 V DC power supply input.
- Incorporates a number of powerful functions despite its compact size, including automatic current reduction circuits to minimize motor heat generation.
- Compact size makes it ideal for incorporation into other equipment.
- New lower price.

## Specifications

Model	KR-5M-SS
Input power supply	DC24 ~ 40V 3A Max
Drive current	0 to about 0.9 A/phase Max
Drive system	Bipolar pentagon drive system FULL step 0.72° HALF step 0.36°
Operating temperature range	0 ~ 40°C
Weight	Approx. 100g

## Wire connection chart

CN1		Details	Signal	Pin No.	Function details
1	Input signal		H.O-	1	"Motor excitation off" control signal
2			H.O+	2	Motor excitation off for "1"
3			R-	3	Reverse signal input for clock 2
4			R+ (for clock 2)	4	Rotation-direction input for clock 1 Normal rotation for "1"; reverse rotation for "0"
5			F-	5	Normal signal input for clock 2 Pulse input for clock 1
6			F+ (for clock 2)	6	

CN2		Details	Signal	Pin No.	Function details
1	Motor lead wire connections			1	Black
2				2	Green
3				3	Orange
4				4	Red
5				5	Blue
6	Power supply		GND	6	Drive power Supply: 0V
7				7	
8			+V	8	Drive power Supply: DC20 ~ 40V
9				9	
10			+5V	10	Maximum supply of 30 mA

Compatible connector: 60-8263-3068-15-000 Kyocera Elco

Compatible connector: 60-8263-3108-15-000 Kyocera Elco

## External dimensions (Unit: mm)

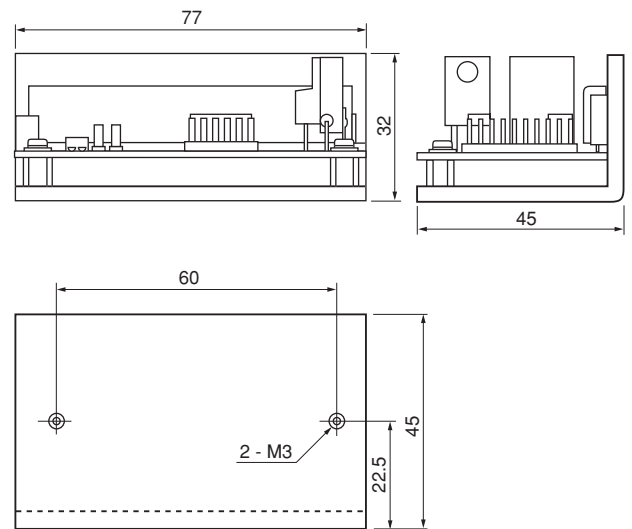

Dimensions do not include protruding items such as screws.

## Input pulse characteristics

- Pulse width 5  $\mu$ s Min
- Pulse interval 5  $\mu$ s Min
- Rise/fall time 1  $\mu$ s Max
- Max pulse frequency 70K pps
- Pulse voltage [1] 4V ~ 8V  
[0] 0.5V ~ -8V
- Internal resistance 390  $\Omega$

## Signal input circuit

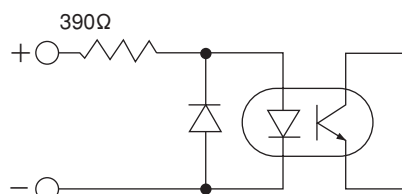

## Input time chart

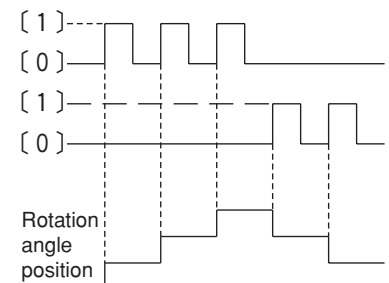



## Explanation of function selector switch



No.	Function	ON	OFF
1	Step angle	0.72° /pulse	0.36° /pulse
2	Clock system	Clock 1	Clock 2

## Wire connection diagram

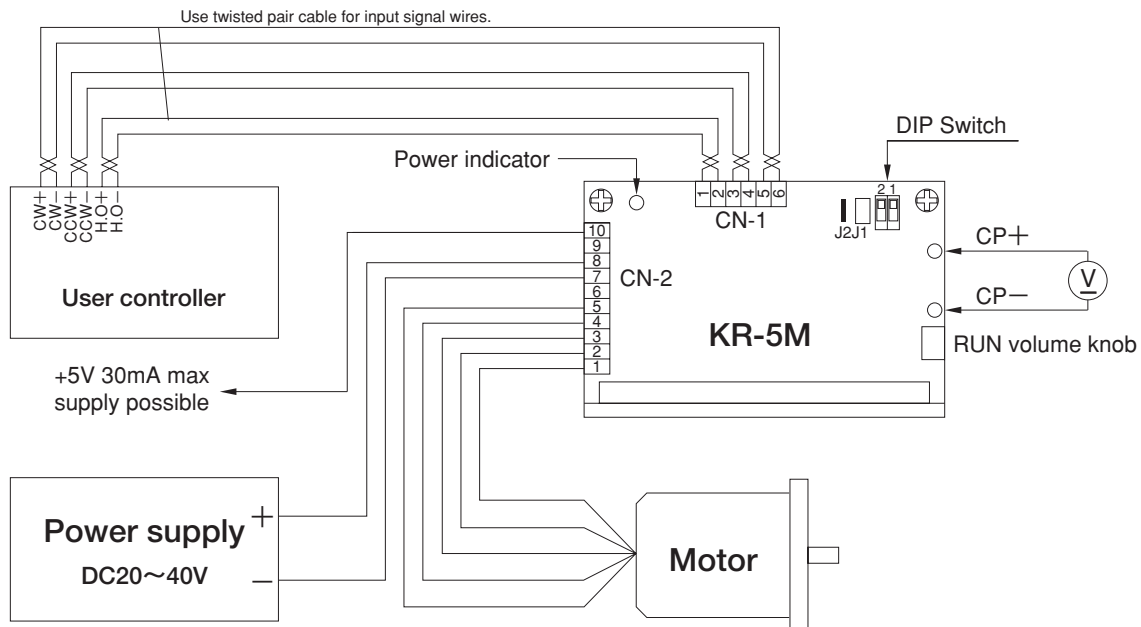

Note 1: The numbers on CN1 and CN2 should be those shown in the diagram or on the connectors. Do not use the numbers on the printed circuit board.

Note 2: Pins 6 to 7 and 8 to 9 are connected internally on CN2.

## Drive current settings

Connect a voltmeter across CP1+ and CP2- on the board, and turn the RUN volume knob to set the voltage determined as follows.

Check pin voltage (V) = Set current x 4

Set to 0.35 A/phase when shipped

- (1) Turn the RUN volume knob fully counterclockwise before switching on the power.
- (2) Apply a normal or reverse signal with a frequency of at least 10 pps and turn the RUN volume knob slowly to set the calculated voltage value.

Note that the motor will turn when the signal is applied.

- (3) The current setting for automatic current reduction is fixed at approximately 60% of the rated current.
- (4) The motor shaft will be free, both when rotating or when stopped, as long as H.O. is set to "1".

# Five-phase micro-step driver

# KR-55ME-SS

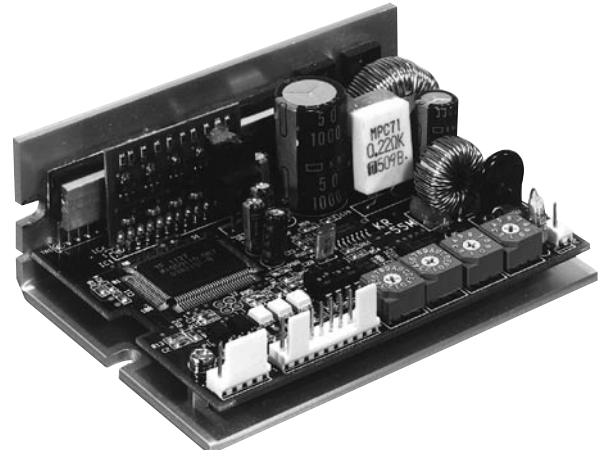

## Features

- Micro-step driver for five-phase stepping motors with a 24V DC power supply input.
- 16 step angle types can be set with up to 250 divisions and 125,000 pulses per revolution.
- A low-vibration function ensures reduced vibration for full-step drive.
- Two types of micro-step angle can be selected as required using a selector signal.

## Specifications

Model	KR-55ME-SS
Input power supply	DC24V ± 10% 3A Max
Drive current	0.23 to 0.75 A/phase Max
Drive system	Micro-step drive system
Operating temperature range	0 ~ 40°C
Weight	Approx. 200g

## Wire connection chart

	Details	Signal	Pin No.	Function details
1	Input signal	F+	1	Pulse signal input for clock 1
2		F-	2	Normal signal input for clock 2
3		R+	3	Rotation direction input for clock 1
4		R-	4	Reverse signal input for clock 2
5		H.O+	5	"Motor excitation off" control signal
6		H.O-	6	Motor excitation off for "1"
7		D.S+	7	Division selector signal
8		D.S-	8	M1 for "0"; M2 for "1"
9	Output signal	Z,P+	9	Origin excitation output signal
10		Z,P-	10	On for origin excitation*

Compatible connector: 5102-10 Molex Japan

	Details	Pin No.	Motor lead wires
1	Motor lead wire connections	1	Blue
2		2	Red
3		3	Orange
4		4	Green
5		5	Black

Compatible connector: 5102-5 Molex Japan

	Details	Pin No.	Function details
1	Power supply	1	+DC24V
2		2	0V

Compatible connector: 5102-02 Molex Japan

Note (\*): On when excitation sequence is "0".  
 Will be output at every interval of 7.2° for 0.72° 5-phase motor.  
 However, may not be output if the step angle is switched after power is switched on.

## External dimensions (Unit: mm)

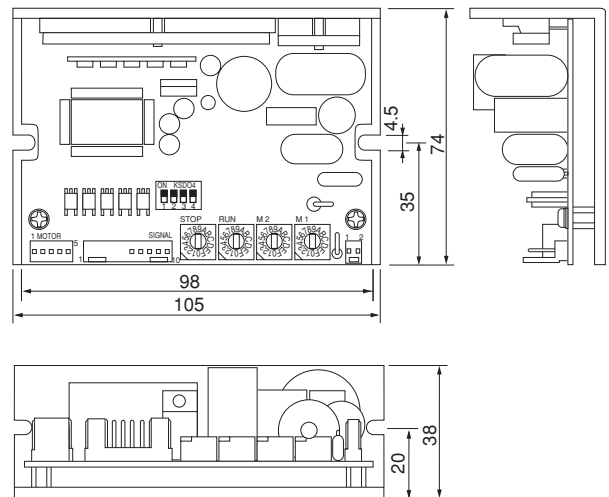

Dimensions do not include protruding items such as screws.

## Input pulse characteristics

- Pulse width: 0.5 μs Min
- Pulse interval: 0.5 μs Min
- Rise/fall time: 1 μs Max
- Max pulse frequency: 500K pps
- Pulse voltage: [1] 4V ~ 8V  
[0] 0.5V ~ -8V
- Internal resistance: 300Ω (F,R)  
390Ω (H.O, D.S)

## Signal input circuit

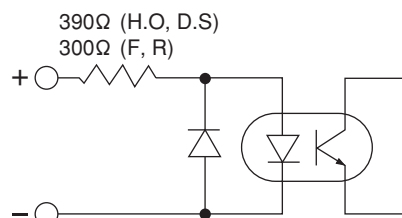

## Signal output circuit

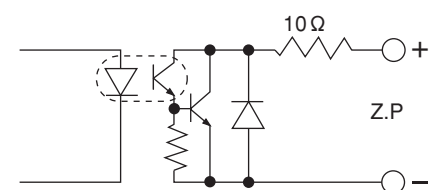

## Explanation of function selector switch



No.	Label on identification plate	Function	ON	OFF
1	TEST	Self test function	Rotates at approximately 60 pps	Normal
2	2/1CK	Clock system selector	Clock 1	Clock 2
3	C.D	Automatic current reduction	Do not use current reduction	Use current reduction
4	OP	Optional	Off when in use	

Note 1

Note 2

Note 1: Rotates at approximately 60 pps regardless of division setting. Rotates clockwise for clock 2, and rotation direction depends on R input for clock 1 (counter-clockwise when R input is "0").

Note 2: The automatic current reduction function reduces the current through the motor when the motor is stopped, to minimize generation of motor heat. Current is reduced approximately 150 ms after the last pulse input.

Holding torque also decreases when current reduction is in operation.

## Micro-step settings

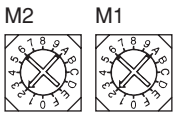

Division setting chart

SW.No.	0	1	2	3	4	5	6	7	8	9
Number of divisions	1	2	4	5	8	10	20	40	80	16

	A	B	C	D	E	F
Micro-step angle per pulse = $\frac{\text{Basic step angle}}{\text{Number of divisions}}$	25	50	100	125	200	250

(1) While driving, if only one micro-step drive is used, set the number of divisions using digital switch M1.

(2) When two micro-step drives are used (to vary the forward and backward speeds for reciprocating motion, for example) set the number of divisions using digital switches M1 and M2.

## Drive current settings

Set the current for motor operation by selecting the digital rotary RUN switch position as shown below.

Drive current setting chart (Digital rotary RUN switch)

SW.No.	0	1	2	3	4	5	6	7	8	9
Current (A)	0.23	0.27	0.30	0.35	0.38	0.41	0.45	0.48	0.52	0.54

	A	B	C	D	E	F
	0.59	0.61	0.66	0.69	0.72	0.75



Example: Motor Settings for Rated Current 0.35A/Phase is adjusting SW to 3.

## Current reduction setting

Set the current for the motor when the motor is stopped by selecting the digital rotary STOP switch position as shown below. The figures in the chart show percentages of the RUN current settings.

Current reduction setting chart (Digital rotary STOP switch)

SW.No.	0	1	2	3	4	5	6	7	8	9
%	27	31	36	40	45	50	54	58	62	66

	A	B	C	D	E	F
	70	74	78	82	86	90



Example: When Drive Current is 0.3A/Phase adjusting SW to 5, 0.15A/Phase of electricity will flow into the motor at the time of stop.

Free Selection Motors of Standard Actuator

# KUMI-ML

# KUMIKO-ML

Motor Free Type

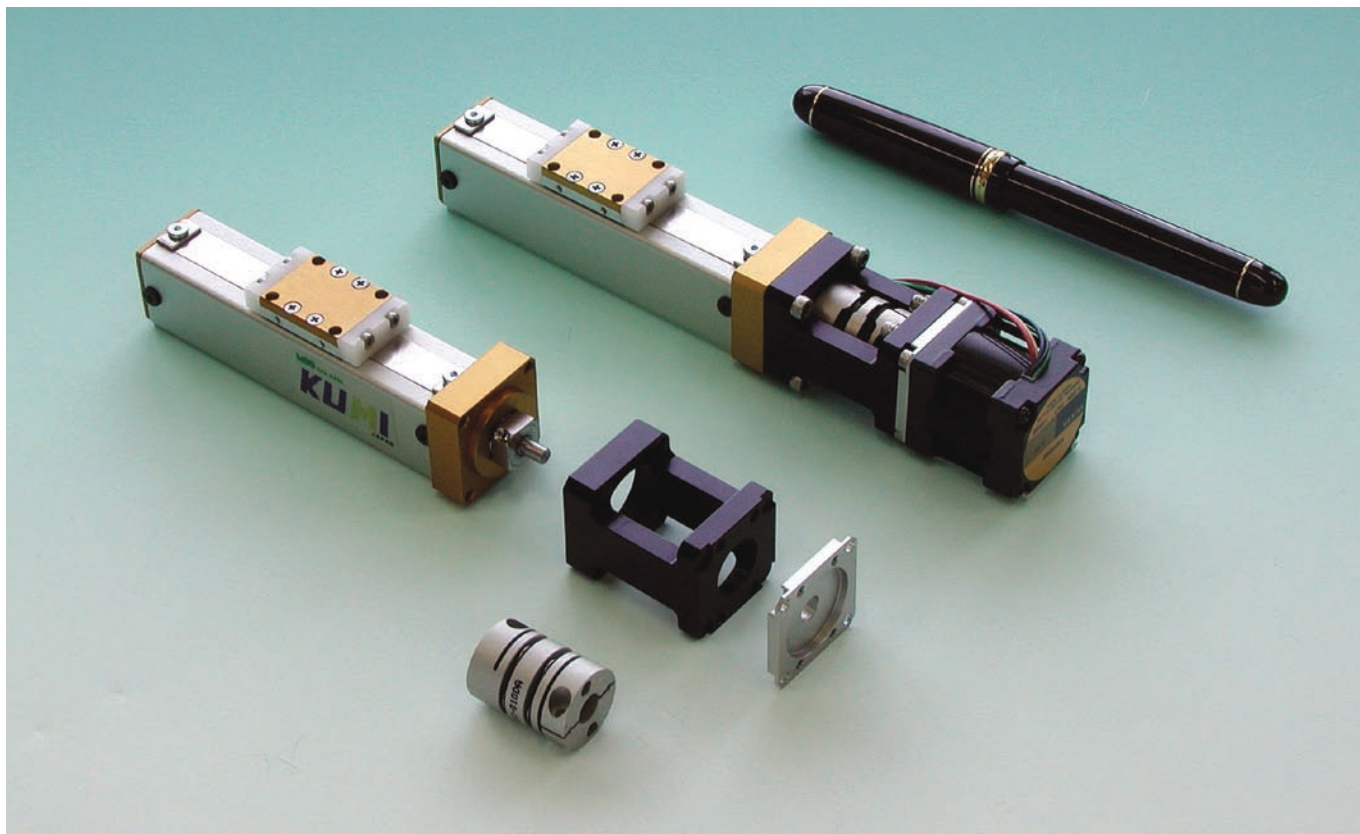

## Features

- Based on KUMI and KUMIKO series, fitted to various motors for various requirements.
- Meet to various control making it easy to use.
- Parts for various motors, and sensors (option) are available. Free combination.
- Compact size with light weight.

## System diagram

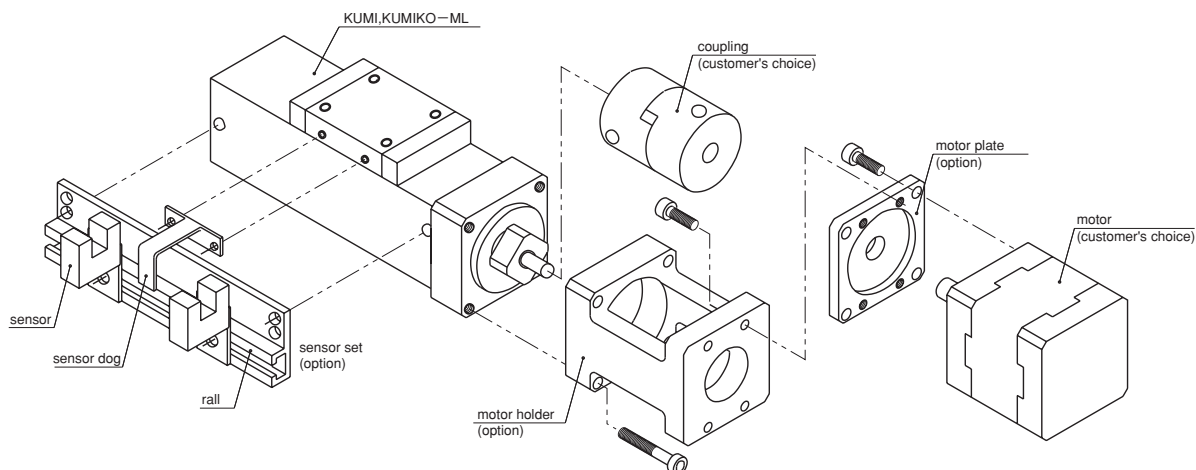

## Description

KUMI-ML-10-MH-MP1-SE M10

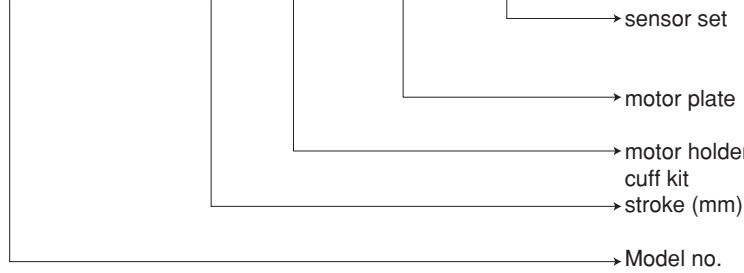

KUMI→M10,M30,M60  
 KUMIKO→K40,K60,K120,K200  
 No sign→No sensor  
 MP1,MP2,MP3,MP4,MP5  
 No sign→No motor plate  
 No sign→No motor holder  
 No sign→No cuff kit  
 KUMI 10,30,60  
 KUMIKO 40,60,120,200  
 KUMI, KUMIKO

## Specification diagram

KUMI-ML

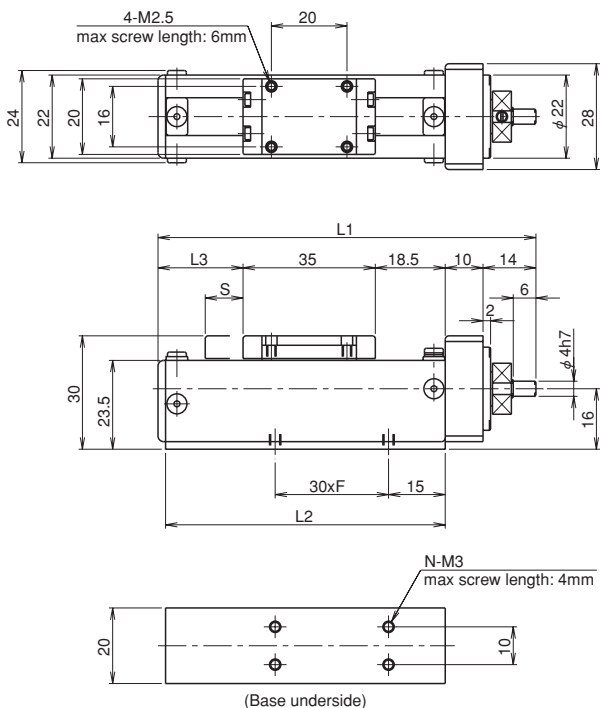

	L1	L2	L3	S	F	N
KUMI ML- 10	100	74	22.5	10	1	4
KUMI ML- 30	120	94	42.5	30	2	6
KUMI ML- 60	150	124	72.5	60	3	8

KUMIKO-ML

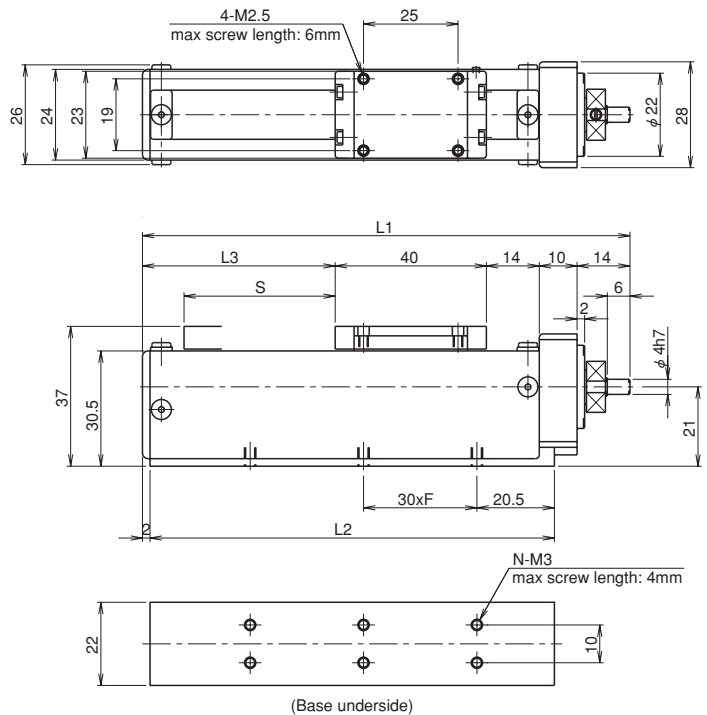

	L1	L2	L3	S	F	N
KUMIKO ML- 40	129	107	51	40	2	6
KUMIKO ML- 60	149	127	71	60	3	8
KUMIKO ML-120	209	187	131	120	5	12
KUMIKO ML-200	289	267	211	200	7	16

## Specifications

Model	Unit	KUMI-ML	KUMIKO-ML
Stroke	(mm)	10, 30, 60	40, 60, 120, 200
Repeated positioning accuracy	(mm)	$\pm 0.03$	$\pm 0.01$
Maximum horizontal load capacity	N (kgf)	9.8 (1.0) *1	39.2 (4.0) *1
Maximum vertical load capacity	N (kgf)	4.9 (0.5) *1	19.6 (2.0) *1
Maximum load moment *2	N · m (kgf · cm)	MP: 0.2 (2.0) My: 0.3 (2.9) Mr: 0.14 (1.4)	MP: 0.5 (5.0) My: 0.5 (5) Mr: 1.0 (10)
Drive system		Resin lead screw : lead 6mm	Precision rolled ball screw : lead 4mm
Initial lost motion	(mm)	0.1 max	0.01 max
Operating temperature range	(°C)	0 ~ 40	0 ~ 40

\*1: Other than 5 phase stepping motor (PMM33B2) will be different depending on the selection of Motor.

\*2: Maximum load moments - Mp: Permissible moment in screw pitch direction; My: Permissible yaw moment; Mr: Permissible rolling moment

\* Refer to the 22-24 pages for the accessories of KUMI-ML and KUMIKO-ML.

## Accessories for KUMI-ML, KUMIKO-ML (Option)

### Motor holder (KUMI, KUMIKO-ML)

Joining parts for the motor and the actuator.

\* Screws for actuator side attached

#### Description MH

Motor holder

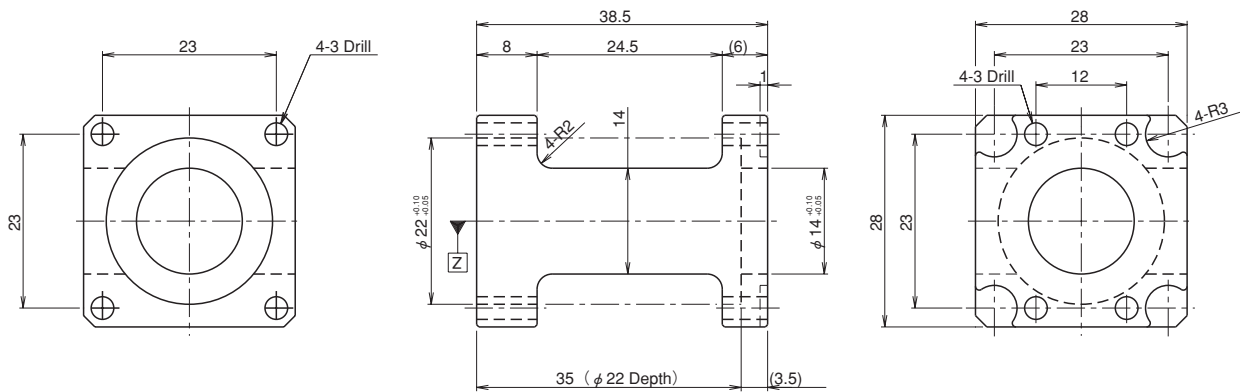

### Sensor set (KUMI, KUMIKO-ML)

Sensor accessories for the purpose of putting sensor to your actuator

Sensor dog / Sensor rail / Photo sensor (SUNX, PM-F24) 2pc. /  
Screw / Sensor plate 2pc.

#### Description SE M10

KUMI → M10, M30, M60

KUMIKO → K40, K60, K120, K200



Settings

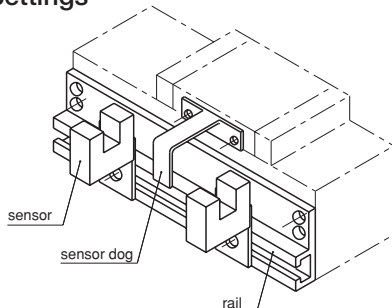

Sensor assembly

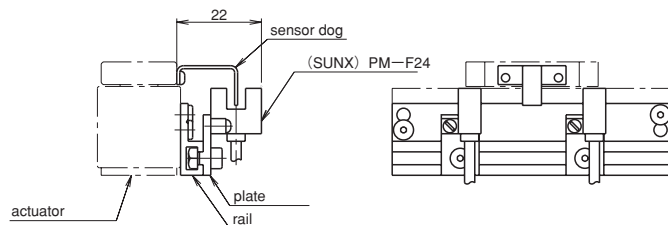

### \* Choosing coupling (Customer's choice)

Recommended below.

Stepping and servo motor SFC-010DA-4B-  B (MIKI Pulley)

Stepping motor MCKLC 20-4-  (MISUMI)

Servo motor MCSLC 20-4-  (MISUMI)

Motor shaft outside diameter

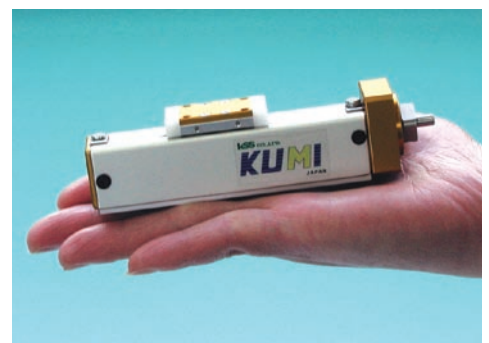

## Motor plate (KUMI, KUMIKO-ML)

Plate for under 28 by 28 motors

\* The motor side attachment screw is also attached.

### Description **MP1**

See blow table

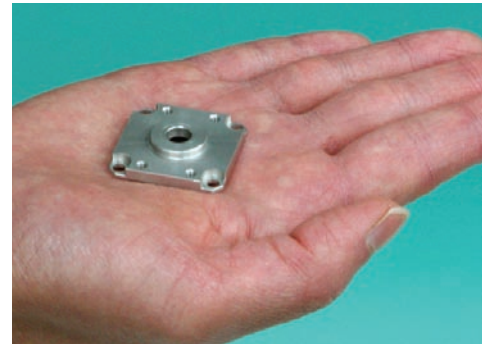

Manufacturer	Description	Motor	Motor plate
YASUKAWA ELECTRIC	AC servo motor	SG MM-A1 (10W)	MP 1
		SG MM-A2 (20W)	
MATSUSHITA ELECTRIC	AC servo motor	MSM 5BZ (5W)	MP 2
		MSM 1AZ (10W)	
		MSM 2AZ (20W)	
MITSUBISHI ELECTRIC	AC servo motor	HC-AQ 013 (10W)	MP 3
		HC-AQ 023 (20W)	
ORIENTAL MOTOR	5 phase stepping motor	PMC 33/35	MP 4
	2 phase stepping motor	PK 223/224/225	
	$\alpha$ step motor	ASC 34/36	
SANYO DENKI	2 phase stepping motor	103H 32	MP 5
	5 phase stepping motor	103H 35	
	Performance servo motor	PBM 282/284	
TAMAGAWA SEIKI	2 phase stepping motor	TS 3641 N1/N2	MP 5
	Stepping motor w/encoder	TS 3699 N112	

### Motor plate

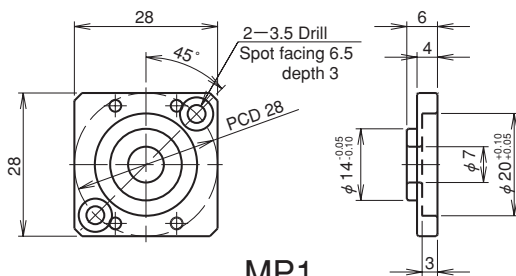

MP1

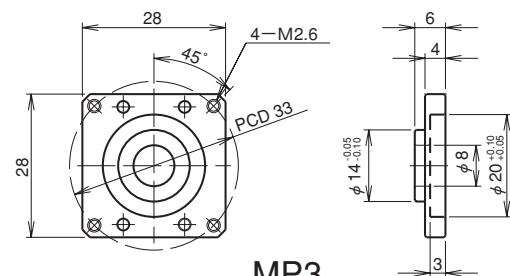

MP3

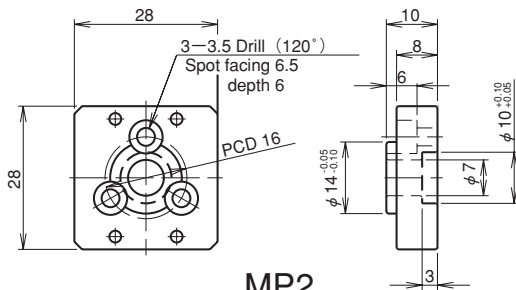

MP2

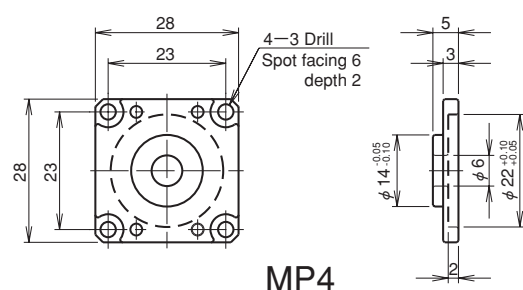

MP4

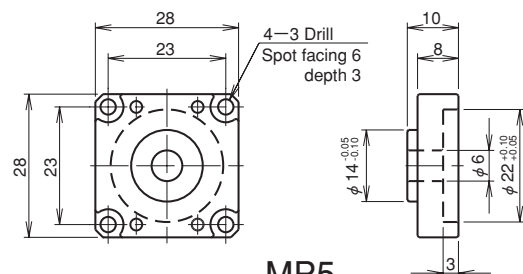

MP5

- \* As a special order, any other brand motors are welcome. Please ask for details.
- \* Accessories are part simple substance sale.
- \* Other different strokes for the standard product, Please contact us.

## Accessories for KUMI-ML, KUMIKO-ML (Option)

### ■ Cuff kit (KUMI, KUMIKO-ML)

It is the cuff kit which can shorten length. And right-and-left attachment is possible.

\* Note: In case the Motor Plate "MP-3" is used, additional working on the Timing Pulley is required. For details, please ask us.

### Description OU

(The set of content)

Motor mount 1 pc. / Timing pulley 2pcs. / Timing bolt 1pc. / Mounting cover bolt 2pcs. /  
Belt cover 1pc. / Mounting screw 1 set



Diagram

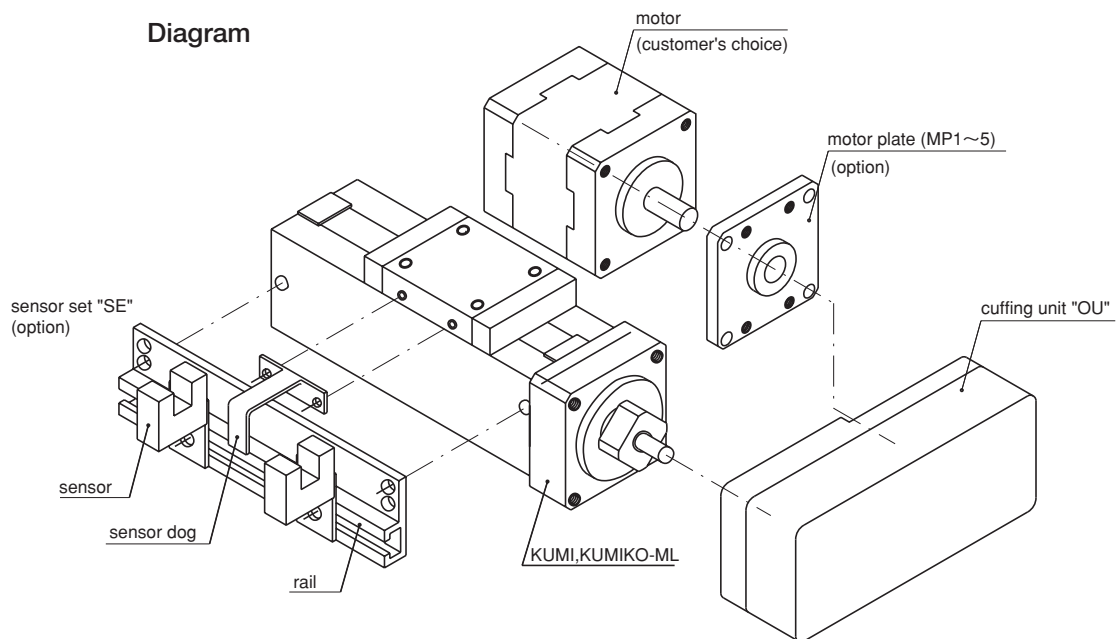

Drawing

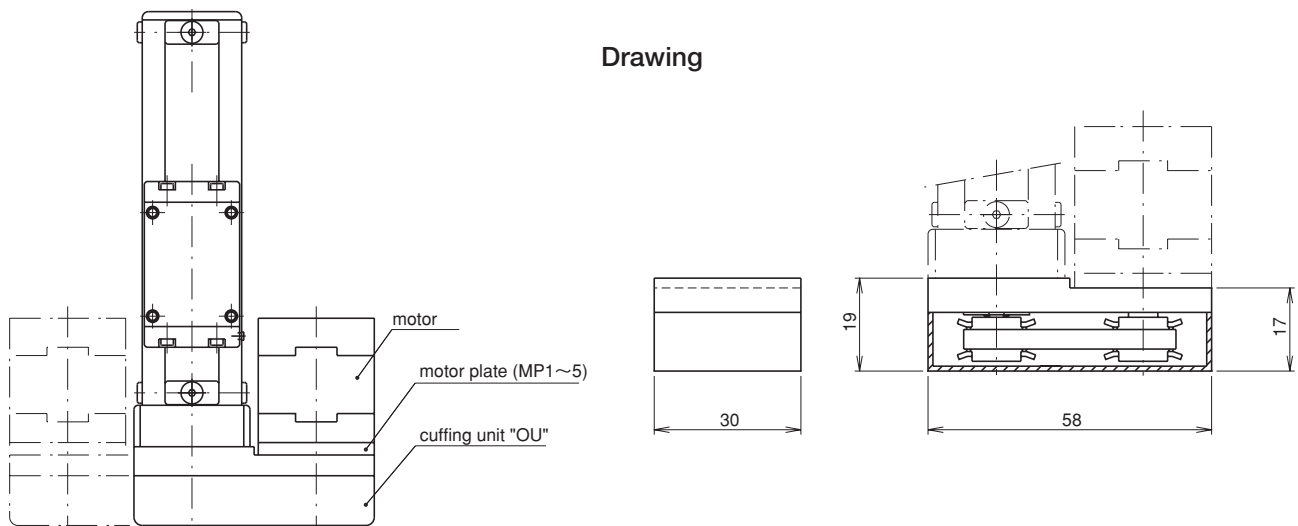



# Ultra miniature actuator special products

**Meeting a wide range of customer needs !!**

## 1. XY type

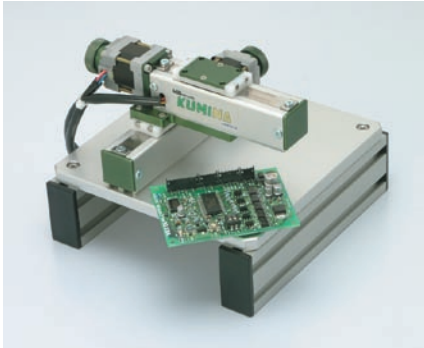

Meets a wide range of needs for two-axis combinations.

## 2. Side motor type



Reduced length is effective in reducing equipment size.

## 3. Long-stroke type

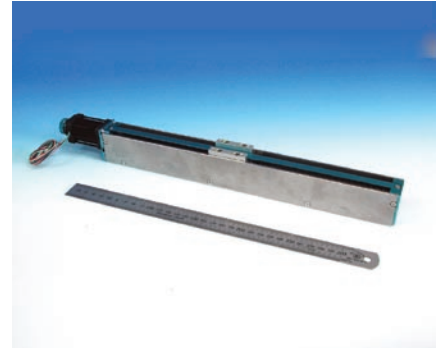

Features a space-saving design with long stroke. (Max. 250mm stroke)

## 4. Different screw lead type



We are proud to offer the option of changing the speed and resolution by changing the lead, an option only ball screw manufacturers can offer.

## 5. Customer-supplied motor assembly type

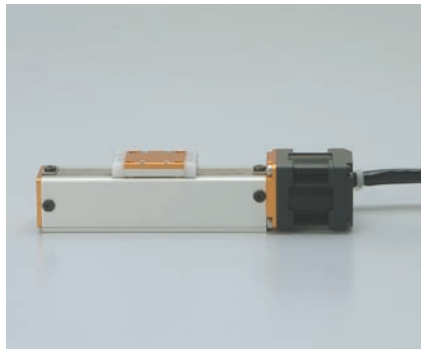

The actuator is assembled in conjunction with a motor provided by the customer.

## 6. Rod type



A long-stroke product in the KUMIRI Series.

## 7. System products

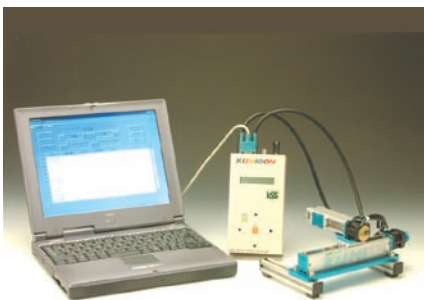

We provide combinations of software and controllers, such as XYZ.

## 8. Manufacturing application



We offer solutions for user applications based on our expertise as a maker of miniature ball screws.

## 9. Customer-specified units

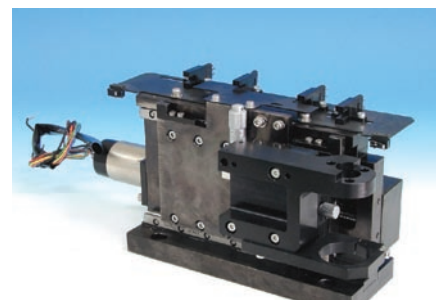

We provide variety of assembled units to satisfy our users' needs.



## Safety Precautions for Using the Ultra Miniature Actuator

### ■ Cautions when using ■

- ☆ As the ultra miniature actuator series is of precision machinery, when subjected to an excess load or sudden impacts, a loss of precision or damage to parts may result.
- ☆ Do not pull the motor lines or sensor cords. The lines may snap and operations may be curtailed.
- ☆ The ultra miniature actuator series is manufactured and assembled to a high degree of precision. Do not disassemble or reconstruct.
- ☆ Slide screws (nut MC nylon) in the KUMI series are coated with ceramic grease (manufactured by TAMIYA). Ball screws in the KUMIKO, KUMINA series and ball screws and lead screws in the KUMIRI series are coated with LG2 (manufactured by NSK, Ltd.) grease. Depending on how they are being used, the old grease should be wiped away and replaced with clean grease every six months, or in cases of long distance, return trips, every three months. To recoat the grease, remove the side cover (the side without sensor lines) by removing the bolts and cover with a hexagonal wrench. After coating, move the slider of dust protection part back so that the side cover can be entered into the dust protection part and bolts can be tightened. The KUMIRI series has a plastic cover on the side which can be opened with a spatula. The 5SP side cover is opened with screws. After coating, reinsert the cover.
- ☆ Avoid using in hot and humid environments.
- ☆ Always contact KSS when using a motor driver other than those specified in the KSS catalog. Doing so will invalidate the warrantee.
- ☆ Sensors within the actuator
  - 1) The KUMI and KUMIKO series use limit switch sensors. (Point of contact is a mechanical system.) There is one (manufactured by OMRON, type D3C-1210) internally, only on the motor side. (The KUMI and KUMIKO-ML series use an external photo sensor (manufactured by SUNX, type PM-F24).
  - 2) The KUMIRI, KUMINA series use photo micro sensors. They are internal on both the motor side and the opposite side (manufactured by OMRON, type EE-SX1103, 1105), run by DC5V (50mA. max). If you find that it does not correspond to your controller, please contact our company. A sensor amp base is available as an option, so please inquire as needed.

### ■ Safety Precautions ■

- ☆ When using this product perpendicularly and a load is put on the sliding part when the power is turned off, the sliding part may fall due to its own weight, within the stroke range. Please be cautious. If you want to keep the position while the power is off, an optional magnetic brake unit is available. Please contact our company for details.
- ☆ This product has not been designed specific to usage that requires a high degree of safety such as medical equipment and safety parts on machinery used for maintaining and control life or body. Human life is not guaranteed. Please use this product with the understanding that it guarantees only under those outlined for this product.
- ☆ Do not use at a voltage other than that shown on the machinery. Fire or trouble may result.
- ☆ Do not touch electrical equipment with wet hands. Electric shock may result.
- ☆ Do not turn, twist, pull, apply heat or place heavy objects on cords. Electric shock or fire may result.
- ☆ Do not touch unit or operating part while in operation or immediately after operation is stopped. Injury may result.
- ☆ Do not touch the terminal for at least five minutes after turning off the power. Electric shock from residual voltage may result.
- ☆ When attaching or removing connecting terminals, be sure to turn off the power and remove the plug before performing this. Electric shock or fire may result.
- ☆ Do not place flammable items or objects that cut off air circulation around the item. Damage to the apparatus may result.
- ☆ If the power goes out, shut off the machine. If the motor comes on suddenly when power is restored, injury or damage to the apparatus may result.

# About KSS

## Products

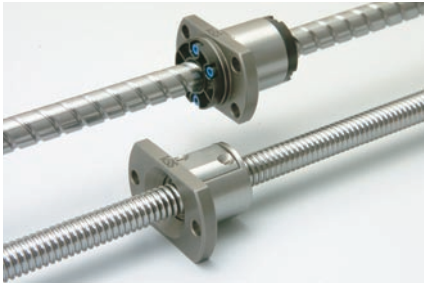

①

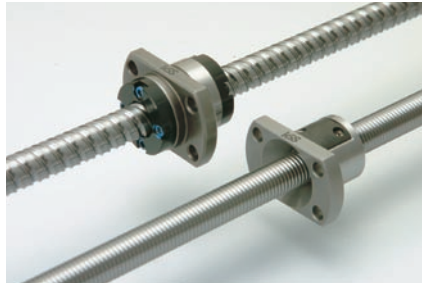

②



③



④

- ① Ground ball screw standard product series .....“SG”
- ② Roll ball screw standard product series .....“SR”
- ③ Ground bi-directional ball screw standard product series .....“SD”
- ④ Ultra precision lead screw series .....“MG”
- ⑤ KUMI application  
MFA (Mini factory automation)
- ⑥ Ultra precision positioning: Nano-Stage Unit
- ⑦ Direct motor drive ball screw “MOBO”  
Direct motor drive resin lead screw “Resin MOBO”

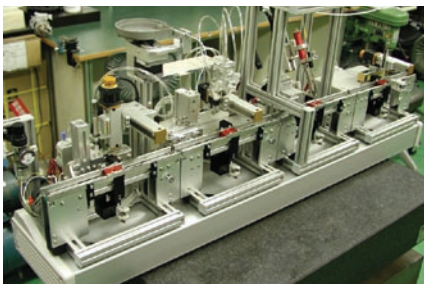

⑤



⑥



⑦

## Head Office / Ojiya Plant



Head Office

Ojiya Plant





---

**kSS** CO.,LTD.

HEAD OFFICE: 1-22-14, Yaguchi, Ota-ku, Tokyo, Japan

Tel. +81-3-3756-3921 Fax. +81-3-3756-3191

URL: <http://www.kss-ball screw.com> <http://www.kss-superdrive.co.jp>