

# SRT/SSRT系列 台阶型冷轧滚珠丝杠标准库存品

## SRT/SSRT series

### Standardized Rolled Ball Screws with Integrated end-journal

由于加工上的关系, 传统的冷轧滚珠丝杠在加工时需要缩小轴端直径。但通过采用本公司的特殊技术, 可以像切削加工品一样, 将单侧(固定侧)设定得比滚珠丝杠部大。

For production reason, Rolled Ball Screws are normally necessary to have smaller end-journal, but as KSS have adopted special technology, it enables fixed end-journal bigger than Shaft diameter alike solid Ball Screws. This technology enables stable and more flexible on end-journal design.

#### ●特点

- 轴端直径可进行加粗设计, 因此可使用台阶形或具有通用性的轴承。
- 与精密滚珠丝杠(切削加工品)的标准轴端形状具有兼容性。
- 与插入轴环及热装相比, 稳定性更高。
- 由于不加工轴端而进行库存管理, 提高了设计自由度。
- 也可提供具有防锈功能的不锈钢滚珠丝杠。

#### ●Features

- Design flexibility and wide use of Bearings on end-journal.
- Compatible end-journal to Precision Ball Screws.
- No need to insert or press fit collar as Bearing shoulder.
- Quick delivery due to unfinished end-journal stock.
- Stainless Rolled Ball Screws are also available.

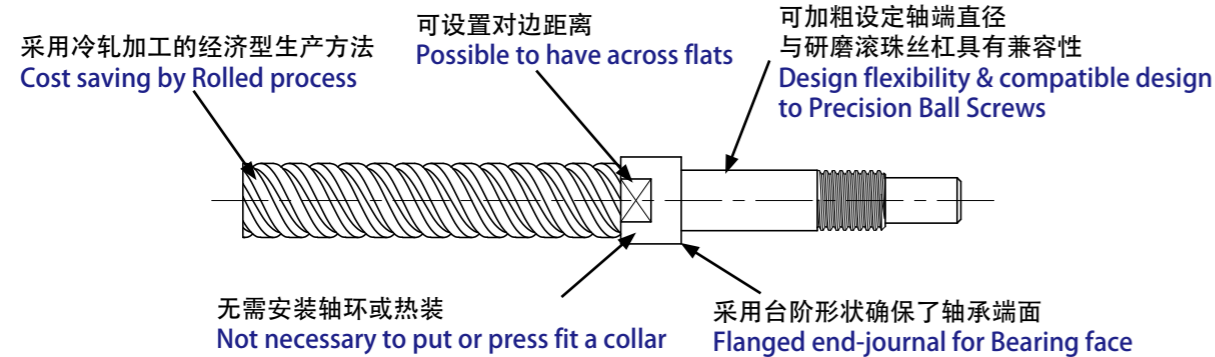

#### ●与传统产品的比较 Comparison with current model

\*\*\*轴径 $\phi 10$ mm产品的比较/ Shaft nominal diameter:  $\phi 10$ mm

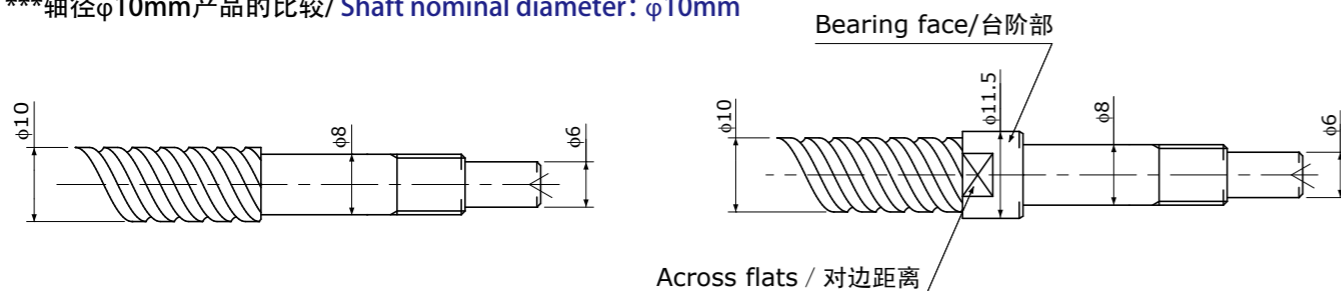

#### ●丝杠轴公称外径与导程的组合 Combination of Shaft nominal dia. & Lead

Unit(单位):mm

Shaft dia. 公称外径	Lead 导程	1	2	2.5	4	5	6	8	10	12	15	20
4		A289 A290	A291									
5					A292							
6		A293 A294 A315	A295				A296		A297			
8		A298 A299 A316	A300 A301 A317	A302		A303		A304		A305		
10			A306 A307 A318			A308			A309		A310	A311
12			A312 A313						A314			

注1) 用黄色标示的型号可提供不锈钢滚珠丝杠。  
注2) 表中的数字表示产品刊载页码。

Note 1) Yellow cells are available for Stainless Shaft and Nut.  
Note 2) The numbers in a table : showing a page in this catalogue

#### ●精度等级和轴向间隙

SRT/SSRT系列(台阶型冷轧/台阶型不锈钢冷轧滚珠丝杠标准库存品)的精度等级为Ct7或Ct10(JIS B-1192)。轴向间隙根据精度等级不同备有0.020mm以下(Ct7)及0.050mm以下(Ct10)两种。

#### ●Accuracy Grade & Axial play

The grade of SRT/SSRT series (Standardized Rolled & Stainless Rolled Ball Screws with Integrated end-journal) are Ct7 or Ct10 (JIS B-1192). According to accuracy grade, Axial play 0.020mm or less (Ct7) and 0.050mm or less (Ct10) are in stock.

#### ●材质和表面硬度

SRT/SSRT系列(台阶型冷轧/台阶型不锈钢冷轧滚珠丝杠标准库存品)的材质和表面硬度如下所示。

#### ●Material & Surface hardness

The material and hardness of SRT/SSRT series (Standardized Rolled & Stainless Rolled Ball Screws with Integrated end-journal) are as follows.

Products 产品类别	Material of thread area 滚珠丝杠部材质	Heat treatment 热处理	Surface hardness 滚珠丝杠部的表面硬度
Rolled Ball Screws (SRT series) 普通冷轧 (SRT系列)	Shaft/丝杠轴: SCM415 S55C	Carburizing and Quenching 渗碳淬火 Induction hardening 高频淬火	HRC58 or more HRC58以上
	Nut/螺母: SCM415		
Stainless Rolled Ball Screws (SSRT series) 不锈钢冷轧 (SSRT系列)	Shaft/丝杠轴: SUS440C	Induction hardening 高频淬火	HRC55 or more HRC55以上
	Nut/螺母: SUS440C	Vacuum hardening 真空淬火	

## ● 润滑

为了防锈, 未对轴端进行加工的SRT/SSRT系列(台阶型冷轧/台阶型不锈钢冷轧滚珠丝杠标准库存品)产品均涂抹有防锈油。

由于防锈油不具备润滑性, 因此在使用前请另行涂抹润滑剂。如无特殊指定, 建议使用KSS原装润滑油脂(MSG No.2)。

## ● 精密冷轧滚珠丝杠

也可生产实现了高精度(JIS C5)的冷轧滚珠丝杠(PSR/PSRT系列)。请参照A319页。

## ● 公称型号的构成 Model number notation

SRT 04 01 K — 086 R 126 C7 B 1 X  
1 2 3 4 5 6 7 8 9 ⑩ ⑪

## 1 系列符号

SRT : 台阶型冷轧滚珠丝杠

SSRT : 台阶型不锈钢冷轧滚珠丝杠

## 2 丝杠轴公称外径(mm)

## 3 导程(mm)

## 4 螺母类型

无符号: 普通型

K: 紧凑型

## 5 螺纹部长度(mm)

(追加加工后以1mm为单位指定)

## 6 螺纹旋向(R=右旋)

## 7 丝杠轴总长(mm)

(以1mm为单位指定)

## 8 精度等级(C7或C10)

## 9 轴端加工类型

(参照图A-24 : A-型、B-型、C-型)

## ⑩ 涂抹的油脂

0: KSS推荐的润滑脂(MSG No.2)

1: 防锈油(Non Ruster PZ2)

2: Multemp PS2

3: 其他

## ⑪ 螺母法兰朝向(参照图A-25)

## ● Lubrication

SRT/SSRT series (Standardized Rolled & Stainless Rolled Ball Screws with Integrated end-journal) will be supplied with anti-rust oil.

This oil is not lubricant, when Ball Screw operates, lubricant should be applied.

If there is no specific instruction, KSS would recommend our original Grease (MSG No.2) as standard lubricant. Please feel free to contact us.

## ● Precision Rolled Ball Screws

High accuracy (JIS C5) can be produced by Rolled process, what we call Precision Rolled Ball Screws (PSR/PSRT series). Please see page -A319.

图A-24: 轴端加工类型

Fig. A-24 : Shaft end-journal profile

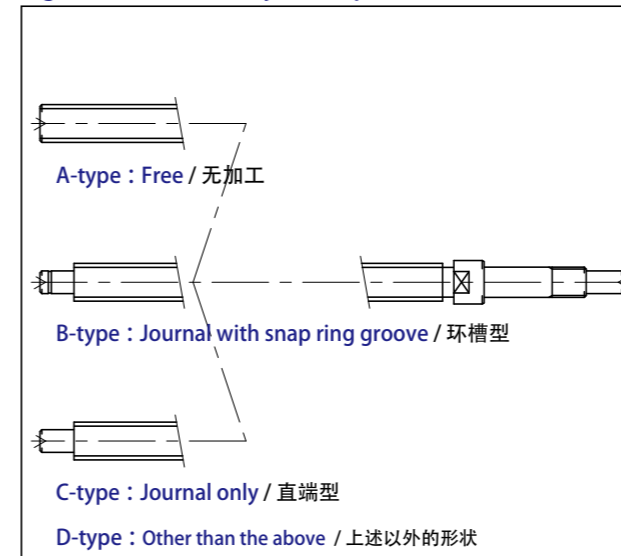

注1) 关于轴端的详细尺寸, 请参照各页。  
注2) 本公司不进行螺母的追加加工。  
注3) 产品规格若有变更, 恕不另行通告。  
注4) 若需要非标准的轴端形状(A、B、C), 请垂询本公司。

图A-25: 螺母法兰朝向

Fig. A-25 : Nut Flange direction

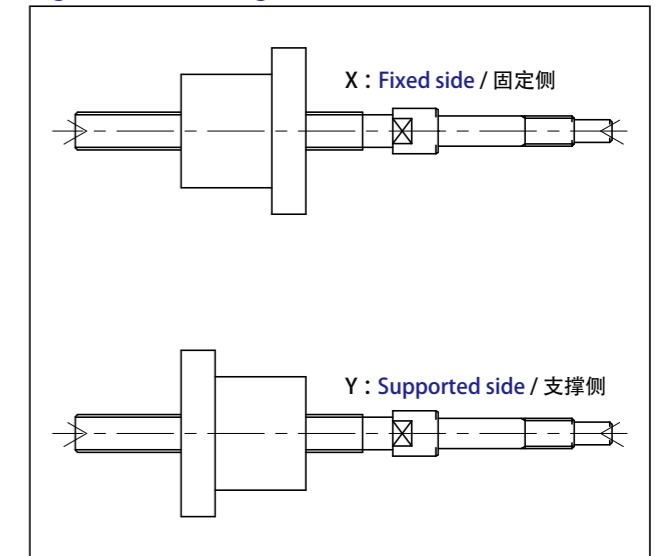

Note 1) The detail of end-journal dimension for each size is shown from next page.

Note 2) KSS does not make additional Nut machining.

Note 3) The specification is subject to change without notice.

Note 4) If the other configuration except (A,B,C) is requested, please contact KSS.

Standard products in stock SRT series  
标准库存品 SRT系列

# SRT0401 | Shaft dia.(轴径)φ4 Lead(导程)1mm | Ct7&Ct10

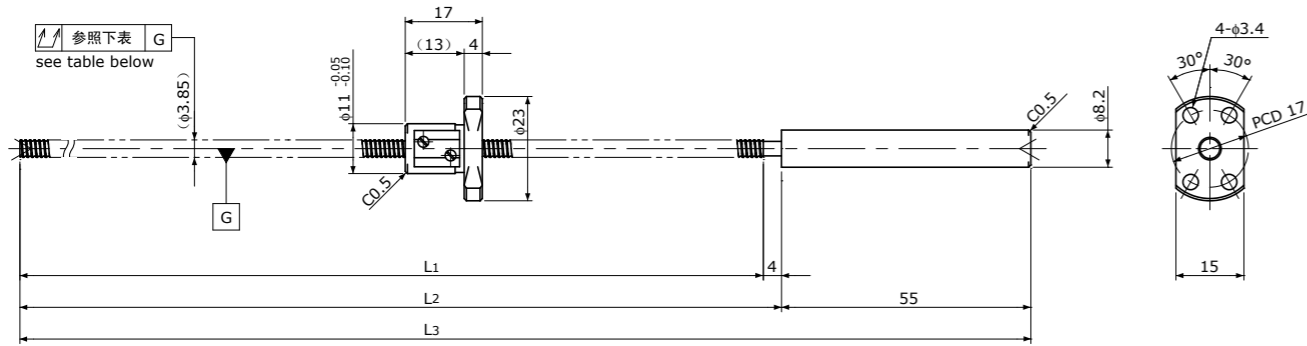

Standard products in stock SRT series  
标准库存品 SRT系列

# SRT0401K | Compact Nut / 紧凑型螺母 | Shaft dia.(轴径)φ4 Lead(导程)1mm | Ct7&Ct10

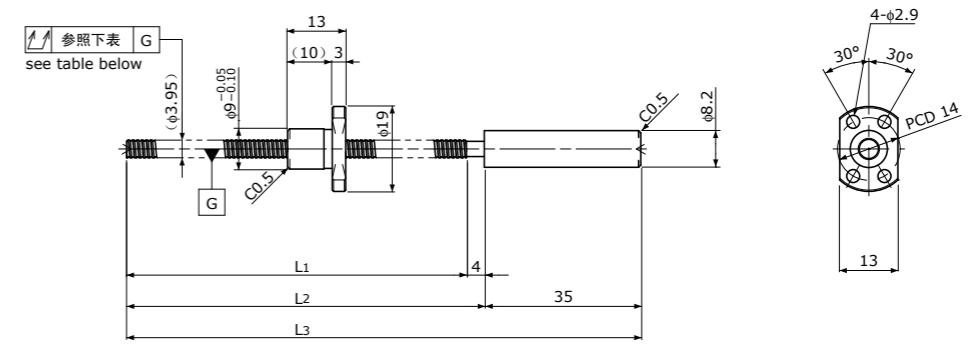

Unit(单位): mm

Ball Screw Specifications 主要技术参数		End-journal profile 轴端加工形状 Supported-side 支撑侧			Fixed-side 固定侧	
Ball size 钢球直径	φ0.8	A-type	B-type	C-type		
Number of thread 螺纹条数	1					
Thread direction 螺纹旋向	Right 右旋	L4=L5-33			L4=L5-40	
Shaft root dia. 丝杠轴底径	φ3.3	L5			L5	
Number of circuit 循环数	3.7×1	R0.2max			R0.2max	
Material 材质	Shaft 轴: SCM415H+SUS303 Nut 螺母: SCM415H	L4=L5-40			L5	
Surface hardness 螺纹部表面硬度	HRC58~(Thread area)	L5			L5	
Anti-rust treatment 防锈处理	Anti-rust oil 防锈油	L5			L5	
Support-unit Recommendation 推荐的支架组件		Supported-side 支撑侧: MSU-4CS/4GS, SUP03-S			Fixed-side 固定侧: MSU-4C/4G, EK4	

L4: Thread length after end-journal machining. 追加加工后的螺纹部长度  
L5: Total length after end-journal machining. 追加加工后的总长

D-type: Other than the above. 上述以外的形状

Unit(单位): mm

Ball Screw Model 滚珠丝杠型号	Travel 行程	Grade 精度	Shaft length 丝杠轴长度			Lead accuracy 导程精度		Total Run-out 全跳动	Axial play 轴向间隙	Preload Torque 预压扭矩 Nm	Basic Load Rating 基本额定负载 N	
			L1	L2	L3	Travel deviation 代表移动量误差 e <sub>p</sub>	Variation 波动 V <sub>300</sub>				Dynamic 额定动负载 Ca	Static 额定静负载 Coa
SRT0401-096R155C7	75	Ct7	96	100	155	±0.02	—	0.080	~0.020	—	560	790
SRT0401-216R275C7	195	Ct7	216	220	275	±0.03	—	0.120				
SRT0401-096R155C10	75	Ct10	96	100	155	±0.06	—	0.160	~0.050	—	560	790
SRT0401-216R275C10	195	Ct10	216	220	275	±0.15	—	0.240				

Note) Please refer to p-A287 for order code of end-journal machining. 注) 追加加工的公称型号指定方式请参照p-A287.

Unit(单位): mm

Ball Screw Specifications 主要技术参数		End-journal profile 轴端加工形状 Supported-side 支撑侧			Fixed-side 固定侧	
Ball size 钢球直径	φ0.6	A-type	B-type	C-type		
Number of thread 螺纹条数	1					
Thread direction 螺纹旋向	Right 右旋	L4=L5-33			L4=L5-40	
Shaft root dia. 丝杠轴底径	φ3.4	L5			L5	
Number of circuit 循环数	1×3	R0.15max			R0.15max	
Material 材质	Shaft 轴: S55C+SUS303 Nut 螺母: SCM415H	L4=L5-40			L5	
Surface hardness 螺纹部表面硬度	HRC58~(Thread area)	L5			L5	
Anti-rust treatment 防锈处理	Anti-rust oil 防锈油	L5			L5	
Support-unit Recommendation 推荐的支架组件		Supported-side 支撑侧: MSU-4CS/4GS, SUP03-S			Fixed-side 固定侧: MSU-4C/4G, EK4	

L4: Thread length after end-journal machining. 追加加工后的螺纹部长度  
L5: Total length after end-journal machining. 追加加工后的总长

D-type: Other than the above. 上述以外的形状

Unit(单位): mm

Ball Screw Model 滚珠丝杠型号	Travel 行程	Grade 精度	Shaft length 丝杠轴长度			Lead accuracy 导程精度		Total Run-out 全跳动	Axial play 轴向间隙	Preload Torque 预压扭矩 Nm	Basic Load Rating 基本额定负载 N	
			L1	L2	L3	Travel deviation 代表移动量误差 e <sub>p</sub>	Variation 波动 V <sub>300</sub>				Dynamic 额定动负载 Ca	Static 额定静负载 Coa
SRT0401K-76R115C7	60	Ct7	76	80	115	±0.02	—	0.080	~0.020	—	300	430
SRT0401K-76R115C10	60	Ct10	76	80	115	±0.05	—	0.160				

Note) Please refer to p-A287 for order code of end-journal machining. 注) 追加加工的公称型号指定方式请参照p-A287.

Standard products in stock SRT series  
标准库存品 SRT系列

## SRT0402 | Shaft dia.(轴径)φ4 Lead(导程)2mm | Ct7&amp;Ct10

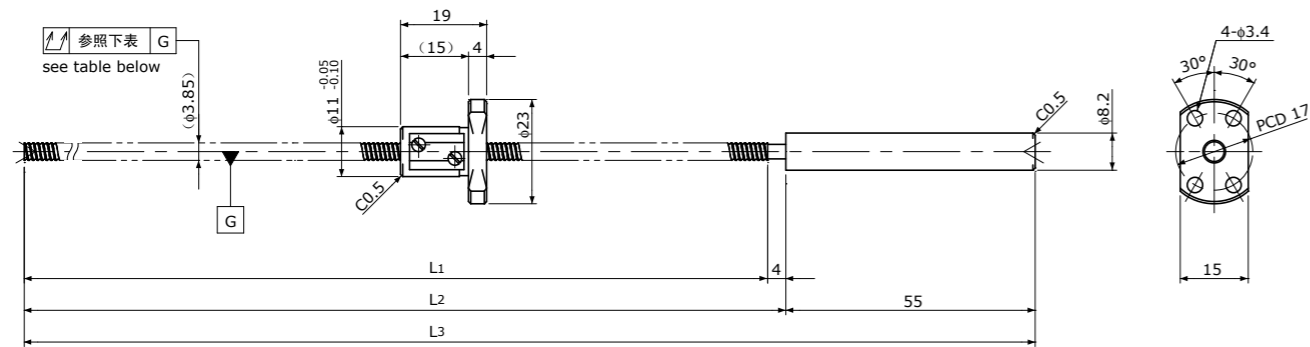

Unit(单位):mm

Ball Screw Specifications 主要技术参数	
Ball size 钢珠直径	φ0.8
Number of thread 螺纹条数	1
Thread direction 螺纹旋向	Right 右旋
Shaft root dia. 丝杠轴底径	φ3.3
Number of circuit 循环数	2.7×1
Material 材质	Shaft 轴 SCM415H+SUS303 Nut 螺母 SCM415H
Surface hardness 螺纹部表面硬度	HRC58~(Thread area)
Anti-rust treatment 防锈处理	Anti-rust oil 防锈油

End-journal profile 轴端加工形状 Supported-side 支撑侧

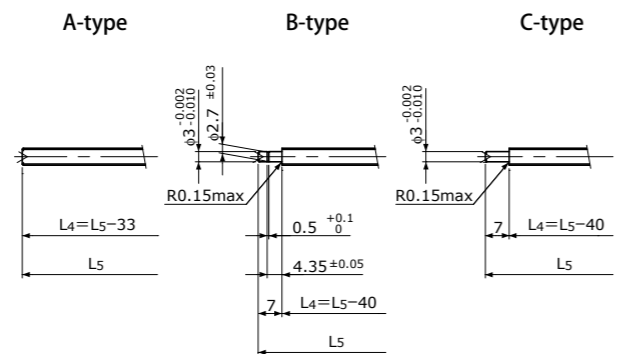
L4: Thread length after end-journal machining. 追加加工后的螺纹部长度  
L5: Total length after end-journal machining. 追加加工后的总长

Support-unit Recommendation 推荐的支架组件	Supported-side 支撑侧	Fixed-side 固定侧
	MSU-4CS/4GS, SUP03-S	MSU-4C/4G, EK4

D-type: Other than the above. 上述以外的形状

Unit(单位):mm

Ball Screw Model 滚珠丝杠型号	Travel 行程	Grade 精度	Shaft length 丝杠轴长度			Lead accuracy 导程精度		Total Run-out 全跳动	Axial play 轴向间隙	Preload Torque 预压扭矩 Nm	Basic Load Rating 基本额定负载 N	
			L1	L2	L3	Travel deviation 代表移动量误差 e <sub>p</sub>	Variation 波动 V <sub>300</sub>				Dynamic 额定动负载 Ca	Static 额定静负载 Coa
SRT0402-096R155C7	75	Ct7	96	100	155	±0.02	—	0.080	~0.020	—	420	570
SRT0402-216R275C7	195	Ct7	216	220	275	±0.03	—	0.120				
SRT0402-096R155C10	75	Ct10	96	100	155	±0.06	—	0.160	~0.050	—	420	570
SRT0402-216R275C10	195	Ct10	216	220	275	±0.15	—	0.240				

Note) Please refer to p-A287 for order code of end-journal machining. 注)追加加工的公称型号指定方式请参照p-A287.

Standard products in stock SRT series  
标准库存品 SRT系列

## SRT0504 | Shaft dia.(轴径)φ5 Lead(导程)4mm | Ct7&amp;Ct10

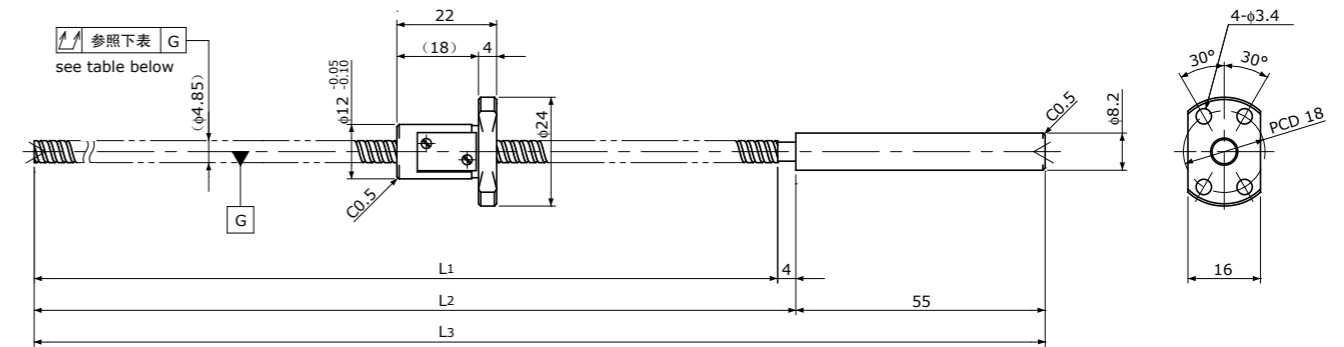

Unit(单位):mm

Ball Screw Specifications 主要技术参数	
Ball size 钢珠直径	φ0.8
Number of thread 螺纹条数	1
Thread direction 螺纹旋向	Right 右旋
Shaft root dia. 丝杠轴底径	φ4.3
Number of circuit 循环数	2.7×1
Material 材质	Shaft 轴 SCM415H+SUS303 Nut 螺母 SCM415H
Surface hardness 螺纹部表面硬度	HRC58~(Thread area)
Anti-rust treatment 防锈处理	Anti-rust oil 防锈油

End-journal profile 轴端加工形状 Supported-side 支撑侧

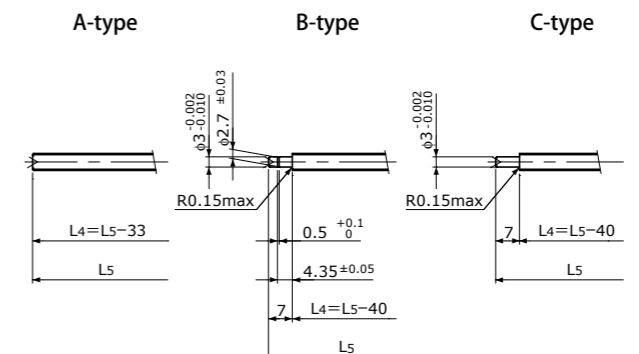
L4: Thread length after end-journal machining. 追加加工后的螺纹部长度  
L5: Total length after end-journal machining. 追加加工后的总长

Support-unit Recommendation 推荐的支架组件	Supported-side 支撑侧	Fixed-side 固定侧
	MSU-4CS/4GS, SUP03-S	MSU-4C/4G, EK4

D-type: Other than the above. 上述以外的形状

Unit(单位):mm

Ball Screw Model 滚珠丝杠型号	Travel 行程	Grade 精度	Shaft length 丝杠轴长度			Lead accuracy 导程精度		Total Run-out 全跳动	Axial play 轴向间隙	Preload Torque 预压扭矩 Nm	Basic Load Rating 基本额定负载 N	
			L1	L2	L3	Travel deviation 代表移动量误差 e <sub>p</sub>	Variation 波动 V <sub>300</sub>				Dynamic 额定动负载 Ca	Static 额定静负载 Coa
SRT0504-096R155C7	70	Ct7	96	100	155	±0.02	—	0.080	~0.020	—	470	720
SRT0504-216R275C7	190	Ct7	216	220	275	±0.03	—	0.120				
SRT0504-096R155C10	70	Ct10	96	100	155	±0.06	—	0.160	~0.050	—	470	720
SRT0504-216R275C10	190	Ct10	216	220	275	±0.15	—	0.240				

Note) Please refer to p-A287 for order code of end-journal machining. 注)追加加工的公称型号指定方式请参照p-A287.





Standard products in stock SRT series  
标准库存品 SRT系列

## SRT0602 | Shaft dia.(轴径)φ6 Lead(导程)2mm | Ct7&amp;Ct10

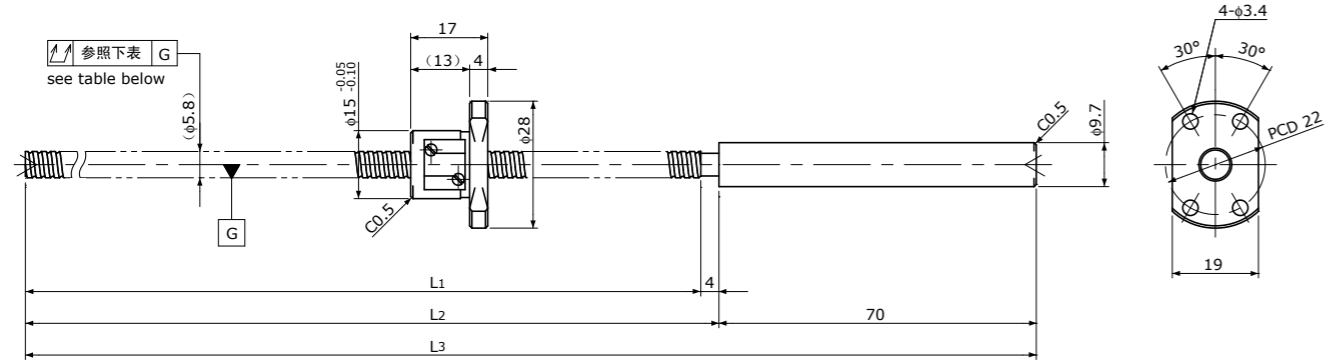

Ball Screw Specifications		主要技术参数
Ball size 钢球直径	φ1.0	
Number of thread 螺纹条数	1	
Thread direction 螺纹旋向	Right 右旋	
Shaft root dia. 丝杠轴底径	φ5.1	
Number of circuit 循环数	2.7×1	
Material 材质	Shaft 轴: SCM415H+SUS303 Nut 螺母: SCM415H	
Surface hardness 螺纹部表面硬度	HRC58~ (Thread area)	
Anti-rust treatment 防锈处理	Anti-rust oil 防锈油	

End-journal profile 轴端加工形状		Supported-side 支撑侧	Fixed-side 固定侧
A-type	B-type	C-type	
L4: Thread length after end-journal machining. 追加加工后的螺纹部长度 L5: Total length after end-journal machining. 追加加工后的总长			
Support-unit Recommendation 推荐的支架组件		Supported-side 支撑侧 : MSU-5CS/5GS, SUP04-S	Fixed-side 固定侧 : MSU-5C/5G, EK5
D-type: Other than the above. 上述以外的形状			

Unit(单位): mm

Ball Screw Model 滚珠丝杠型号	Travel 行程	Grade 精度	Shaft length 丝杠轴长度			Lead accuracy 导程精度		Total Run-out 全跳动	Axial play 轴向间隙	Preload Torque 预压扭矩 Nm	Basic Load Rating 基本额定负载 N	
			L1	L2	L3	Travel deviation 代表移动量误差 e <sub>p</sub>	Variation 波动 V <sub>300</sub>				Dynamic 额定动负载 Ca	Static 额定静负载 Coa
SRT0602-146R220C7	125	Ct7	146	150	220	±0.02	—	0.080	~0.020	—	750	1200
SRT0602-261R335C7	240	Ct7	261	265	335	±0.04	—	0.120				
SRT0602-146R220C10	125	Ct10	146	150	220	±0.10	—	0.160	~0.050	—	750	1200
SRT0602-261R335C10	240	Ct10	261	265	335	±0.18	—	0.240				

Note) Please refer to p-A287 for order code of end-journal machining. 注) 追加加工的公称型号指定方式请参照p-A287.

Standard products in stock SRT series  
标准库存品 SRT系列

## SRT0606 | Shaft dia.(轴径)φ6 Lead(导程)6mm | Ct7&amp;Ct10

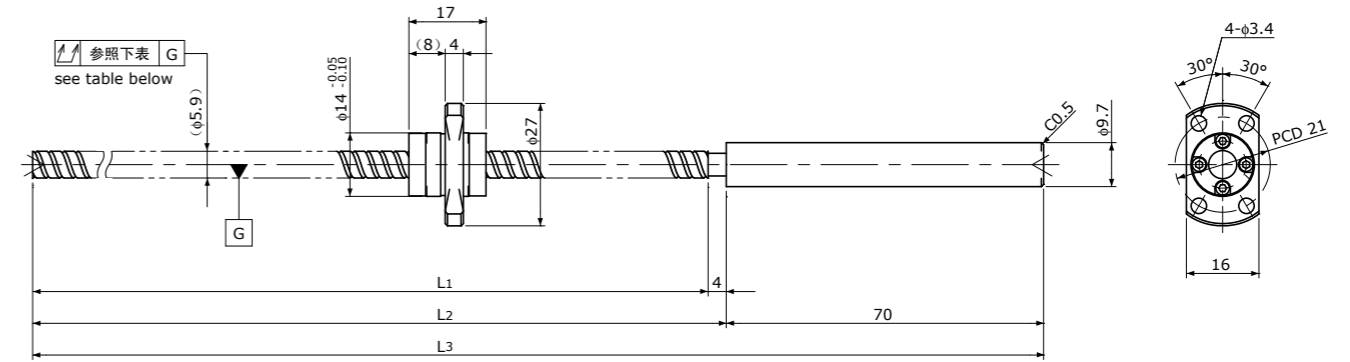

Ball Screw Specifications		主要技术参数
Ball size 钢球直径	φ1.0	
Number of thread 螺纹条数	2	
Thread direction 螺纹旋向	Right 右旋	
Shaft root dia. 丝杠轴底径	φ5.2	
Number of circuit 循环数	1.6×2	
Material 材质	Shaft 轴: SCM415H+SUS303 Nut 螺母: SCM415H	
Surface hardness 螺纹部表面硬度	HRC58~ (Thread area)	
Anti-rust treatment 防锈处理	Anti-rust oil 防锈油	

End-journal profile 轴端加工形状		Supported-side 支撑侧	Fixed-side 固定侧
A-type	B-type	C-type	
L4: Thread length after end-journal machining. 追加加工后的螺纹部长度 L5: Total length after end-journal machining. 追加加工后的总长			
Support-unit Recommendation 推荐的支架组件		Supported-side 支撑侧 : MSU-5CS/5GS, SUP04-S	Fixed-side 固定侧 : MSU-5C/5G, EK5
D-type: Other than the above. 上述以外的形状			

Unit(单位): mm

Ball Screw Model 滚珠丝杠型号	Travel 行程	Grade 精度	Shaft length 丝杠轴长度			Lead accuracy 导程精度		Total Run-out 全跳动	Axial play 轴向间隙	Preload Torque 预压扭矩 Nm	Basic Load Rating 基本额定负载 N	
			L1	L2	L3	Travel deviation 代表移动量误差 e <sub>p</sub>	Variation 波动 V <sub>300</sub>				Dynamic 额定动负载 Ca	Static 额定静负载 Coa
SRT0606-146R220C7	125	Ct7	146	150	220	±0.02	—	0.080	~0.020	—	870	1450
SRT0606-261R335C7	240	Ct7	261	265	335	±0.04	—	0.120				
SRT0606-146R220C10	125	Ct10	146	150	220	±0.10	—	0.160	~0.050	—	870	1450
SRT0606-261R335C10	240	Ct10	261	265	335	±0.18	—	0.240				

Note) Please refer to p-A287 for order code of end-journal machining. 注) 追加加工的公称型号指定方式请参照p-A287.

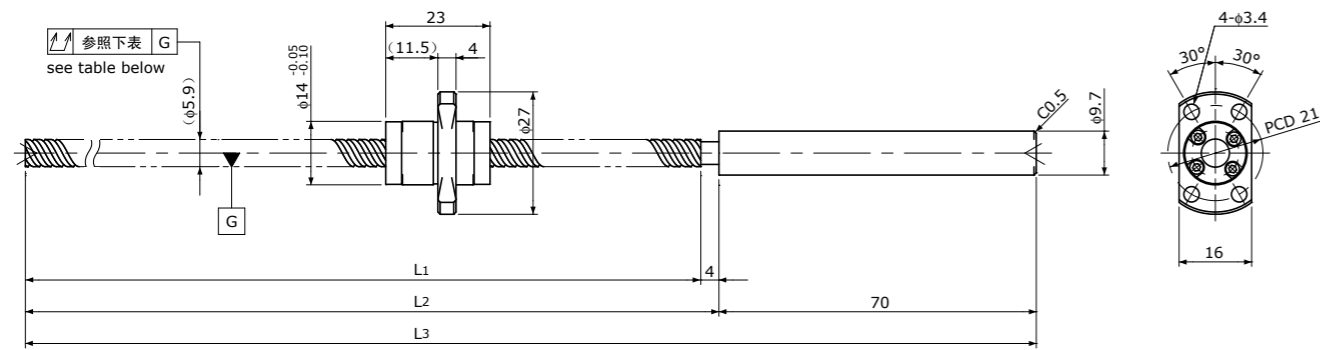
Standard products in stock SRT series  
标准库存品 SRT系列SRT0610 | Shaft dia. (轴径)  $\phi 6$  Lead (导程) 10mm | Ct7&Ct10

Unit (单位) : mm

Ball Screw Specifications 主要技术参数		
Ball size 钢珠直径		$\phi 1.2$
Number of thread 螺纹条数		2
Thread direction 螺纹旋向	Right 右旋	
Shaft root dia. 丝杠轴底径		$\phi 5.0$
Number of circuit 循环数		1.2×2
Material 材质	Shaft 轴	SCM415H+SUS303
	Nut 螺母	SCM415H
Surface hardness 螺纹部表面硬度		HRC58~ (Thread area)
Anti-rust treatment 防锈处理		Anti-rust oil 防锈油

End-journal profile 轴端加工形状 Supported-side 支撑侧

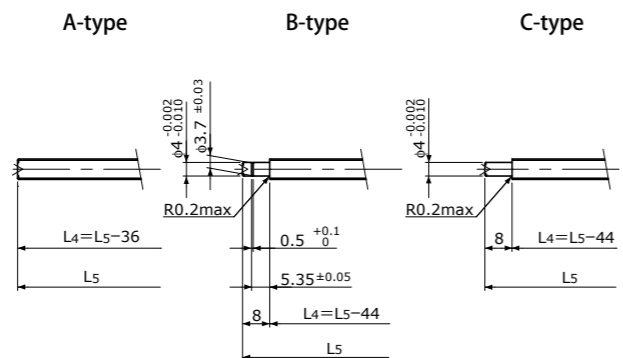

L4: Thread length after end-journal machining. 追加加工后的螺纹部长度  
L5: Total length after end-journal machining. 追加加工后的总长

Support-unit Recommendation 推荐的支架组件	Supported-side 支撑侧	Fixed-side 固定侧
	MSU-5CS/5GS, SUP04-S	MSU-5C/5G, EK5

D-type: Other than the above. 上述以外的形状

Fixed-side 固定侧

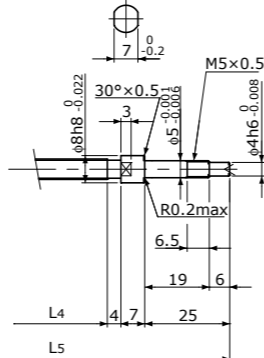

Unit (单位) : mm

Ball Screw Model 滚珠丝杠型号	Travel 行程	Grade 精度	Shaft length 丝杠轴长度			Lead accuracy 导程精度		Total Run-out 全跳动	Axial play 轴向间隙	Preload Torque 预压扭矩 Nm	Basic Load Rating 基本额定负载 N	
			L1	L2	L3	Travel deviation 代表移动量误差 $e_p$	Variation 波动 $V_{300}$				Dynamic 额定动负载 $C_a$	Static 额定静负载 $C_oa$
SRT0610-146R220C7	120	Ct7	146	150	220	$\pm 0.02$	—	0.080	~0.020	—	950	1600
SRT0610-261R335C7	235	Ct7	261	265	335	$\pm 0.04$	—	0.120				
SRT0610-146R220C10	120	Ct10	146	150	220	$\pm 0.10$	—	0.160	~0.050	—	950	1600
SRT0610-261R335C10	235	Ct10	261	265	335	$\pm 0.18$	—	0.240				

Note) Please refer to p-A287 for order code of end-journal machining. 注) 追加加工的公称型号指定方式请参照p-A287.

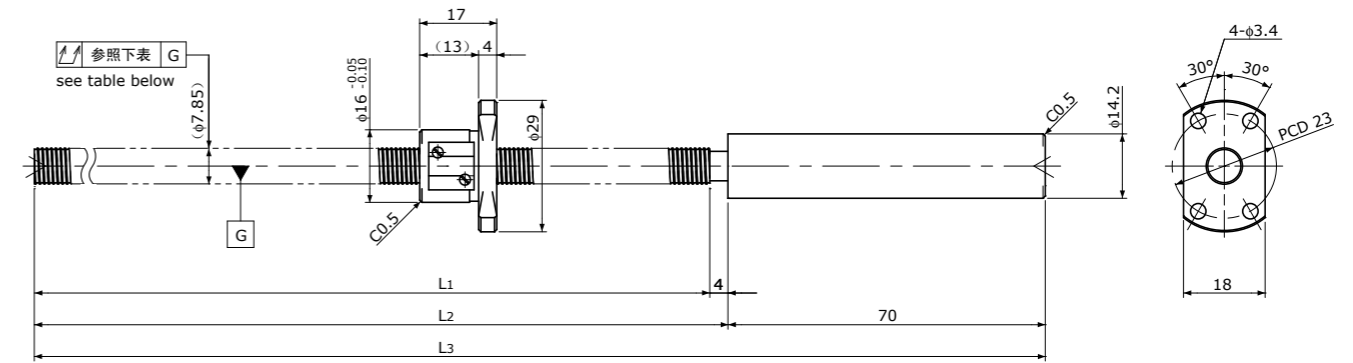
Standard products in stock SRT series  
标准库存品 SRT系列SRT0801 | Shaft dia. (轴径)  $\phi 8$  Lead (导程) 1mm | Ct7&Ct10

Unit (单位) : mm

Ball Screw Specifications 主要技术参数		
Ball size 钢珠直径		$\phi 0.8$
Number of thread 螺纹条数		1
Thread direction 螺纹旋向	Right 右旋	
Shaft root dia. 丝杠轴底径		$\phi 7.3$
Number of circuit 循环数		3.7×1
Material 材质	Shaft 轴	SCM415H+SUS303
	Nut 螺母	SCM415H
Surface hardness 螺纹部表面硬度		HRC58~ (Thread area)
Anti-rust treatment 防锈处理		Anti-rust oil 防锈油

End-journal profile 轴端加工形状 Supported-side 支撑侧

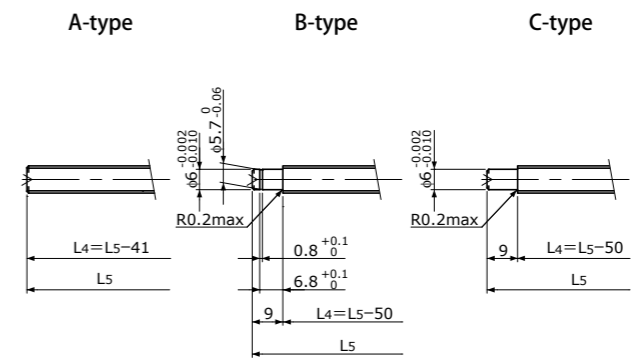

L4: Thread length after end-journal machining. 追加加工后的螺纹部长度  
L5: Total length after end-journal machining. 追加加工后的总长

Support-unit Recommendation 推荐的支架组件	Supported-side 支撑侧	Fixed-side 固定侧
	MSU-6CS/6GS, EF6	MSU-6C/6G, EK6

D-type: Other than the above. 上述以外的形状

Unit (单位) : mm

Ball Screw Model 滚珠丝杠型号	Travel 行程	Grade 精度	Shaft length 丝杠轴长度			Lead accuracy 导程精度		Total Run-out 全跳动	Axial play 轴向间隙	Preload Torque 预压扭矩 Nm	Basic Load Rating 基本额定负载 N	
			L1	L2	L3	Travel deviation 代表移动量误差 $e_p$	Variation 波动 $V_{300}$				Dynamic 额定动负载 $C_a$	Static 额定静负载 $C_oa$
SRT0801-196R270C7	175	Ct7	196	200	270	$\pm 0.03$	—	0.080	~0.020	—	780	1650
SRT0801-356R430C7	335	Ct7	356	360	430	$\pm 0.06$	0.05	0.120				
SRT0801-196R270C10	175	Ct10	196	200	270	$\pm 0.13$	—	0.160	~0.050	—	780	1650
SRT0801-356R430C10	335	Ct10	356	360	430	$\pm 0.24$	0.21	0.240				

Note) Please refer to p-A287 for order code of end-journal machining. 注) 追加加工的公称型号指定方式请参照p-A287.

Standard products in stock SRT series  
标准库存品 SRT系列

**SRT0801K** | Compact Nut / 紧凑型螺母  
Shaft dia. (轴径)  $\phi 8$  Lead (导程) 1mm | Ct7&Ct10

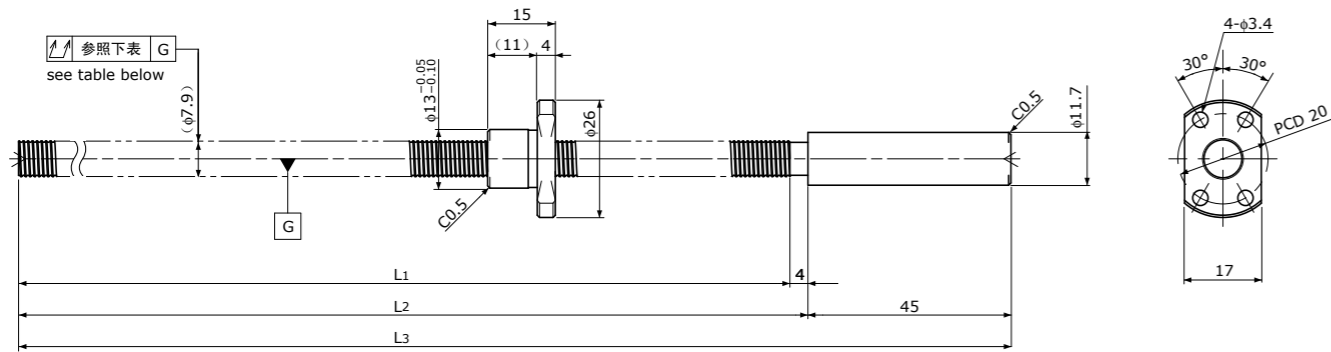

Ball Screw Specifications		主要技术参数
Ball size 钢球直径		$\phi 0.8$
Number of thread 螺纹条数		1
Thread direction 螺纹旋向		Right 右旋
Shaft root dia. 丝杠轴底径		$\phi 7.3$
Number of circuit 循环数		1×3
Material 材质	Shaft 轴 Nut 螺母	S55C+SUS303 SCM415H
Surface hardness 螺纹部表面硬度		HRC58~ (Thread area)
Anti-rust treatment 防锈处理		Anti-rust oil 防锈油

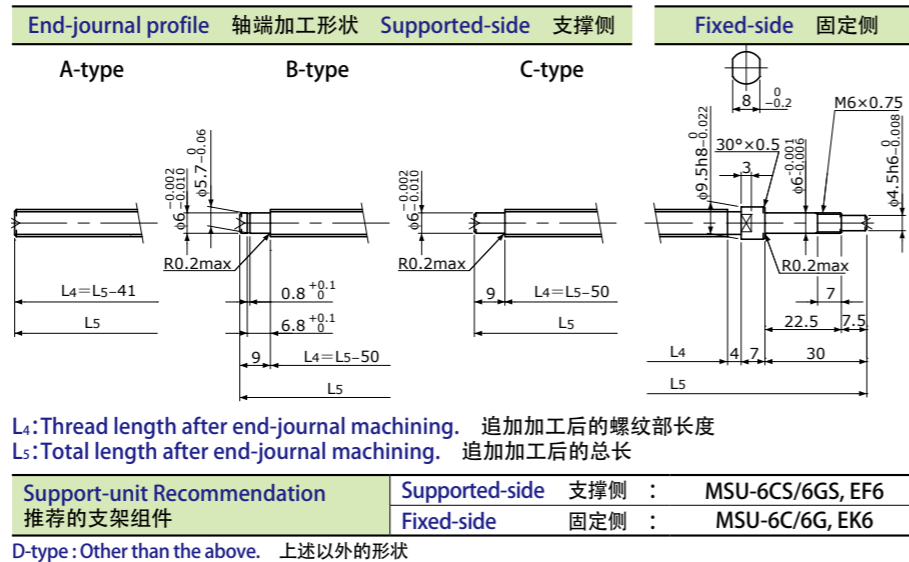

Ball Screw Model 滚珠丝杠型号	Travel 行程	Grade 精度	Shaft length 丝杠轴长度			Lead accuracy 导程精度		Total Run-out 全跳动	Axial play 轴向间隙	Preload Torque 预压扭矩 Nm	Basic Load Rating 基本额定负载 N	
			L1	L2	L3	Travel deviation 代表移动量误差 $e_p$	Variation 波动 $V_{300}$				Dynamic 额定动负载 Ca	Static 额定静负载 Coa
SRT0801K-171R220C7	150	Ct7	171	175	220	$\pm 0.03$	—	0.080	~0.020	—	650	1300
SRT0801K-171R220C10	150	Ct10	171	175	220	$\pm 0.11$	—	0.160	~0.050	—	650	1300

Note) Please refer to p-A287 for order code of end-journal machining. 注) 追加加工的公称型号指定方式请参照p-A287.

Standard products in stock SRT series  
标准库存品 SRT系列

**SRT0802** | Shaft dia. (轴径)  $\phi 8$  Lead (导程) 2mm | Ct7&Ct10

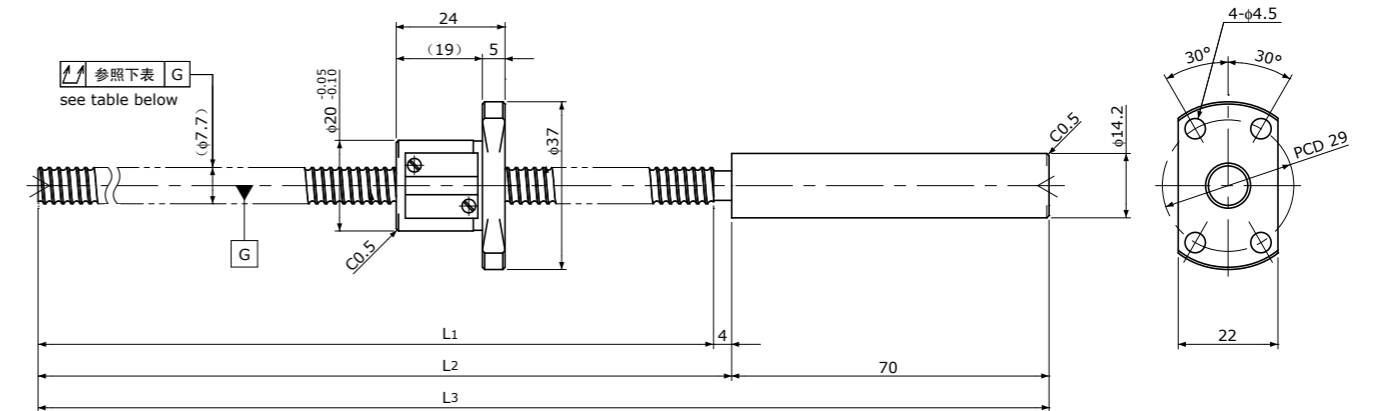

Ball Screw Specifications		主要技术参数
Ball size 钢球直径		$\phi 1.5875$
Number of thread 螺纹条数		1
Thread direction 螺纹旋向		Right 右旋
Shaft root dia. 丝杠轴底径		$\phi 6.6$
Number of circuit 循环数		3.7×1
Material 材质	Shaft 轴 Nut 螺母	SCM415H+SUS303 SCM415H
Surface hardness 螺纹部表面硬度		HRC58~ (Thread area)
Anti-rust treatment 防锈处理		Anti-rust oil 防锈油

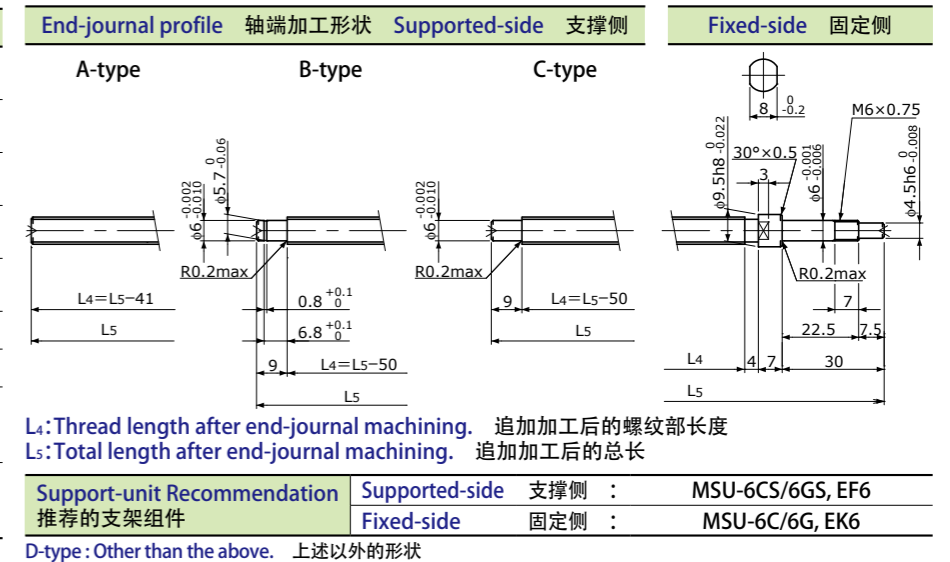

Ball Screw Model 滚珠丝杠型号	Travel 行程	Grade 精度	Shaft length 丝杠轴长度			Lead accuracy 导程精度		Total Run-out 全跳动	Axial play 轴向间隙	Preload Torque 预压扭矩 Nm	Basic Load Rating 基本额定负载 N	
			L1	L2	L3	Travel deviation 代表移动量误差 $e_p$	Variation 波动 $V_{300}$				Dynamic 额定动负载 Ca	Static 额定静负载 Coa
SRT0802-196R270C7	170	Ct7	196	200	270	$\pm 0.03$	—	0.080	~0.020	—	2400	4100
SRT0802-356R430C7	330	Ct7	356	360	430	$\pm 0.06$	0.05	0.120	~0.020	—	2400	4100
SRT0802-196R270C10	170	Ct10	196	200	270	$\pm 0.13$	—	0.160	~0.050	—	2400	4100
SRT0802-356R430C10	330	Ct10	356	360	430	$\pm 0.24$	0.21	0.240	~0.050	—	2400	4100

Note) Please refer to p-A287 for order code of end-journal machining. 注) 追加加工的公称型号指定方式请参照p-A287.

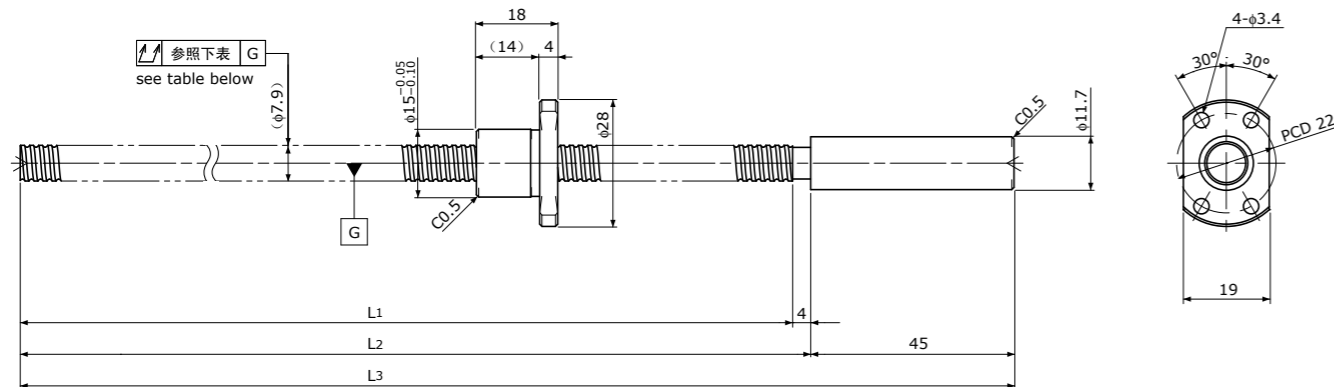
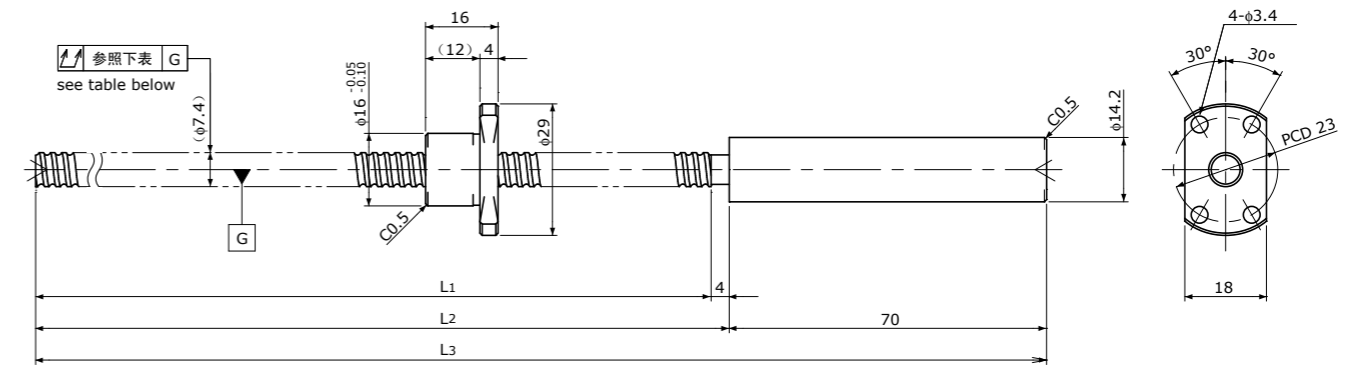

Standard products in stock SRT series  
标准库存品 SRT系列SRT0802K | Compact Nut / 紧凑型螺母  
Shaft dia. (轴径)  $\phi 8$  Lead (导程) 2mm | Ct7&Ct10Standard products in stock SRT series  
标准库存品 SRT系列SRT0802.5 | Shaft dia. (轴径)  $\phi 8$  Lead (导程) 2.5mm | Ct7&Ct10

Unit (单位) : mm

Ball Screw Specifications 主要技术参数		End-journal profile 轴端加工形状 Supported-side 支撑侧			Fixed-side 固定侧
Ball size 钢球直径	$\phi 1.2$	A-type	B-type	C-type	
Number of thread 螺纹条数	1				
Thread direction 螺纹旋向	Right 右旋	<p>L4: Thread length after end-journal machining. 追加加工后的螺纹部长度 L5: Total length after end-journal machining. 追加加工后的总长</p>			
Shaft root dia. 丝杠轴底径	$\phi 7.0$	<p>Support-unit Recommendation 推荐的支架组件</p>			
Number of circuit 循环数	1×3	<p>Supported-side 支撑侧 : MSU-6CS/6GS, EF6 Fixed-side 固定侧 : MSU-6C/6G, EK6</p>			
Material 材质	Shaft 轴 S55C+SUS303 Nut 螺母 SCM415H	<p>D-type: Other than the above. 上述以外的形状</p>			
Surface hardness 螺纹部表面硬度	HRC58~ (Thread area)				
Anti-rust treatment 防锈处理	Anti-rust oil 防锈油				

Unit (单位) : mm

Ball Screw Model 滚珠丝杠型号	Travel 行程	Grade 精度	Shaft length 丝杠轴长度			Lead accuracy 导程精度		Total Run-out 全跳动	Axial play 轴向间隙	Preload Torque 预压扭矩 Nm	Basic Load Rating 基本额定负载 N	
			L1	L2	L3	Travel deviation 代表移动量误差 $e_p$	Variation 波动 $V_{300}$				Dynamic 额定动负载 $C_a$	Static 额定静负载 $C_oa$
SRT0802K-171R220C7	145	Ct7	171	175	220	$\pm 0.03$	—	0.080	$\sim 0.020$	—	1300	2300
SRT0802K-171R220C10	145	Ct10	171	175	220	$\pm 0.11$	—	0.160	$\sim 0.050$	—	—	—

Note) Please refer to p-A287 for order code of end-journal machining. 注) 追加加工的公称型号指定方式请参照p-A287.

Unit (单位) : mm

Ball Screw Specifications 主要技术参数		End-journal profile 轴端加工形状 Supported-side 支撑侧			Fixed-side 固定侧
Ball size 钢球直径	$\phi 1.5875$	A-type	B-type	C-type	
Number of thread 螺纹条数	1				
Thread direction 螺纹旋向	Right 右旋	<p>L4: Thread length after end-journal machining. 追加加工后的螺纹部长度 L5: Total length after end-journal machining. 追加加工后的总长</p>			
Shaft root dia. 丝杠轴底径	$\phi 6.3$	<p>Support-unit Recommendation 推荐的支架组件</p>			
Number of circuit 循环数	2.7×1	<p>Supported-side 支撑侧 : MSU-6CS/6GS, EF6 Fixed-side 固定侧 : MSU-6C/6G, EK6</p>			
Material 材质	Shaft 轴 SCM415H+SUS303 Nut 螺母 SCM415H	<p>D-type: Other than the above. 上述以外的形状</p>			
Surface hardness 螺纹部表面硬度	HRC58~ (Thread area)				
Anti-rust treatment 防锈处理	Anti-rust oil 防锈油				

Unit (单位) : mm

Ball Screw Model 滚珠丝杠型号	Travel 行程	Grade 精度	Shaft length 丝杠轴长度			Lead accuracy 导程精度		Total Run-out 全跳动	Axial play 轴向间隙	Preload Torque 预压扭矩 Nm	Basic Load Rating 基本额定负载 N	
			L1	L2	L3	Travel deviation 代表移动量误差 $e_p$	Variation 波动 $V_{300}$				Dynamic 额定动负载 $C_a$	Static 额定静负载 $C_oa$
SRT0802.5-196R270C7	180	Ct7	196	200	270	$\pm 0.03$	—	0.080	$\sim 0.020$	—	1850	3000
SRT0802.5-356R430C7	340	Ct7	356	360	430	$\pm 0.06$	0.05	0.120	$\sim 0.020$	—	—	—
SRT0802.5-196R270C10	180	Ct10	196	200	270	$\pm 0.13$	—	0.160	$\sim 0.050$	—	—	—
SRT0802.5-356R430C10	340	Ct10	356	360	430	$\pm 0.24$	0.21	0.240	$\sim 0.050$	—	—	—

Note) Please refer to p-A287 for order code of end-journal machining. 注) 追加加工的公称型号指定方式请参照p-A287.

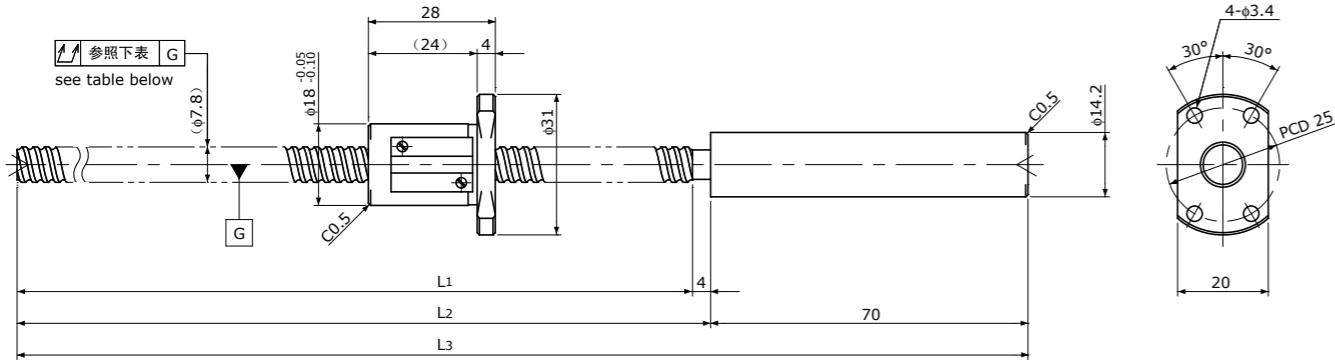
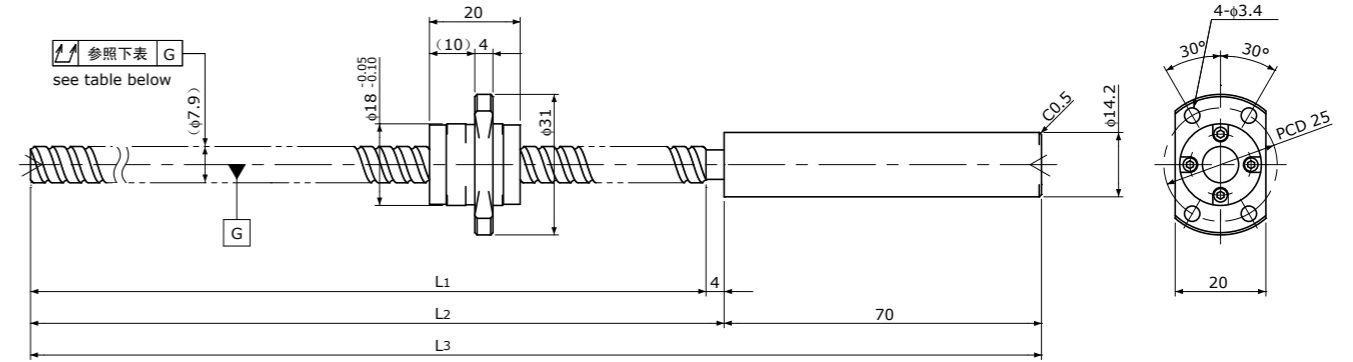
Standard products in stock SRT series  
标准库存品 SRT系列SRT0805 | Shaft dia.(轴径)  $\phi 8$  Lead(导程) 5mm | Ct7&Ct10Standard products in stock SRT series  
标准库存品 SRT系列SRT0808 | Shaft dia.(轴径)  $\phi 8$  Lead(导程) 8mm | Ct7&Ct10

Unit(单位): mm

Ball Screw Specifications 主要技术参数		End-journal profile 轴端加工形状 Supported-side 支撑侧			Fixed-side 固定侧	
Ball size 钢球直径	$\phi 1.5875$	A-type	B-type	C-type		
Number of thread 螺纹条数	1					
Thread direction 螺纹旋向	Right 右旋	<p>L4: Thread length after end-journal machining. 追加加工后的螺纹部长度 L5: Total length after end-journal machining. 追加加工后的总长</p>			<p>L4: Thread length after end-journal machining. 追加加工后的螺纹部长度 L5: Total length after end-journal machining. 追加加工后的总长</p>	
Shaft root dia. 丝杠轴底径	$\phi 6.6$	<p>Support-unit Recommendation 推荐的支架组件</p>			<p>Supported-side 支撑侧 : MSU-6CS/6GS, EF6 Fixed-side 固定侧 : MSU-6C/6G, EK6</p>	
Number of circuit 循环数	2.7 × 1	D-type: Other than the above. 上述以外的形状				
Material 材质	Shaft 轴: SCM415H+SUS303 Nut 螺母: SCM415H					
Surface hardness 螺纹部表面硬度	HRC58~ (Thread area)					
Anti-rust treatment 防锈处理	Anti-rust oil 防锈油					

Unit(单位): mm

Ball Screw Model 滚珠丝杠型号	Travel 行程	Grade 精度	Shaft length 丝杠轴长度			Lead accuracy 导程精度		Total Run-out 全跳动	Axial play 轴向间隙	Preload Torque 预压扭矩 Nm	Basic Load Rating 基本额定负载 N	
			L1	L2	L3	Travel deviation 代表移动量误差 $e_p$	Variation 波动 $V_{300}$				Dynamic 额定动负载 $C_a$	Static 额定静负载 $C_oa$
SRT0805-196R270C7	165	Ct7	196	200	270	$\pm 0.03$	—	0.080	~0.020	—	1850	3000
SRT0805-356R430C7	325	Ct7	356	360	430	$\pm 0.06$	0.05	0.120				
SRT0805-196R270C10	165	Ct10	196	200	270	$\pm 0.13$	—	0.160	~0.050	—	1850	3000
SRT0805-356R430C10	325	Ct10	356	360	430	$\pm 0.24$	0.21	0.240				

Note) Please refer to p-A287 for order code of end-journal machining. 注) 追加加工的公称型号指定方式请参照p-A287.

Unit(单位): mm

Ball Screw Specifications 主要技术参数		End-journal profile 轴端加工形状 Supported-side 支撑侧			Fixed-side 固定侧	
Ball size 钢球直径	$\phi 1.5875$	A-type	B-type	C-type		
Number of thread 螺纹条数	2					
Thread direction 螺纹旋向	Right 右旋	<p>L4: Thread length after end-journal machining. 追加加工后的螺纹部长度 L5: Total length after end-journal machining. 追加加工后的总长</p>			<p>L4: Thread length after end-journal machining. 追加加工后的螺纹部长度 L5: Total length after end-journal machining. 追加加工后的总长</p>	
Shaft root dia. 丝杠轴底径	$\phi 6.7$	<p>Support-unit Recommendation 推荐的支架组件</p>			<p>Supported-side 支撑侧 : MSU-6CS/6GS, EF6 Fixed-side 固定侧 : MSU-6C/6G, EK6</p>	
Number of circuit 循环数	1.6 × 2	D-type: Other than the above. 上述以外的形状				
Material 材质	Shaft 轴: SCM415H+SUS303 Nut 螺母: SCM415H					
Surface hardness 螺纹部表面硬度	HRC58~ (Thread area)					
Anti-rust treatment 防锈处理	Anti-rust oil 防锈油					

Unit(单位): mm

Ball Screw Model 滚珠丝杠型号	Travel 行程	Grade 精度	Shaft length 丝杠轴长度			Lead accuracy 导程精度		Total Run-out 全跳动	Axial play 轴向间隙	Preload Torque 预压扭矩 Nm	Basic Load Rating 基本额定负载 N	
			L1	L2	L3	Travel deviation 代表移动量误差 $e_p$	Variation 波动 $V_{300}$				Dynamic 额定动负载 $C_a$	Static 额定静负载 $C_oa$
SRT0808-196R270C7	175	Ct7	196	200	270	$\pm 0.03$	—	0.080	~0.020	—	2200	3800
SRT0808-356R430C7	335	Ct7	356	360	430	$\pm 0.06$	0.05	0.120				
SRT0808-196R270C10	175	Ct10	196	200	270	$\pm 0.13$	—	0.160	~0.050	—	2200	3800
SRT0808-356R430C10	335	Ct10	356	360	430	$\pm 0.24$	0.21	0.240				

Note) Please refer to p-A287 for order code of end-journal machining. 注) 追加加工的公称型号指定方式请参照p-A287.

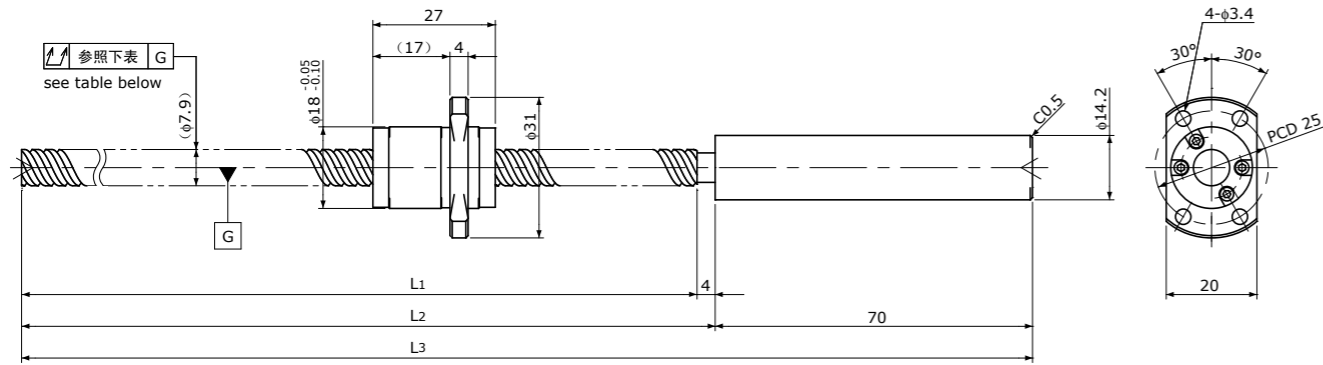
Standard products in stock SRT series  
标准库存品 SRT系列SRT0812 | Shaft dia. (轴径)  $\phi 8$  Lead (导程) 12mm | Ct7&Ct10

Ball Screw Specifications		主要技术参数
Ball size 钢珠直径		$\phi 1.5875$
Number of thread 螺纹条数		2
Thread direction 螺纹旋向		Right 右旋
Shaft root dia. 丝杠轴底径		$\phi 6.7$
Number of circuit 循环数		1.6×2
Material 材质	Shaft 轴 Nut 螺母	SCM415H+SUS303 SCM415H
Surface hardness 螺纹部表面硬度		HRC58~ (Thread area)
Anti-rust treatment 防锈处理		Anti-rust oil 防锈油

End-journal profile 轴端加工形状		Supported-side 支撑侧	Fixed-side 固定侧
A-type	B-type	C-type	
Support-unit Recommendation 推荐的支架组件		Supported-side 支撑侧	Fixed-side 固定侧
		MSU-6CS/6GS, EF6	MSU-6C/6G, EK6
D-type: Other than the above. 上述以外的形状			

Ball Screw Model 滚珠丝杠型号	Travel 行程	Grade 精度	Shaft length 丝杠轴长度			Lead accuracy 导程精度		Total Run-out 全跳动	Axial play 轴向间隙	Preload Torque 预压扭矩 Nm	Basic Load Rating 基本额定负载 N	
			L1	L2	L3	Travel deviation 代表移动量误差 $e_p$	Variation 波动 $V_{300}$				Dynamic 额定动负载 Ca	Static 额定静负载 Coa
SRT0812-196R270C7	165	Ct7	196	200	270	$\pm 0.03$	—	0.080	~0.020	—	2200	4000
SRT0812-356R430C7	325	Ct7	356	360	430	$\pm 0.06$	0.05	0.120				
SRT0812-196R270C10	165	Ct10	196	200	270	$\pm 0.13$	—	0.160	~0.050	—	2200	4000
SRT0812-356R430C10	325	Ct10	356	360	430	$\pm 0.24$	0.21	0.240				

Note) Please refer to p-A287 for order code of end-journal machining. 注) 追加加工的公称型号指定方式请参照p-A287.

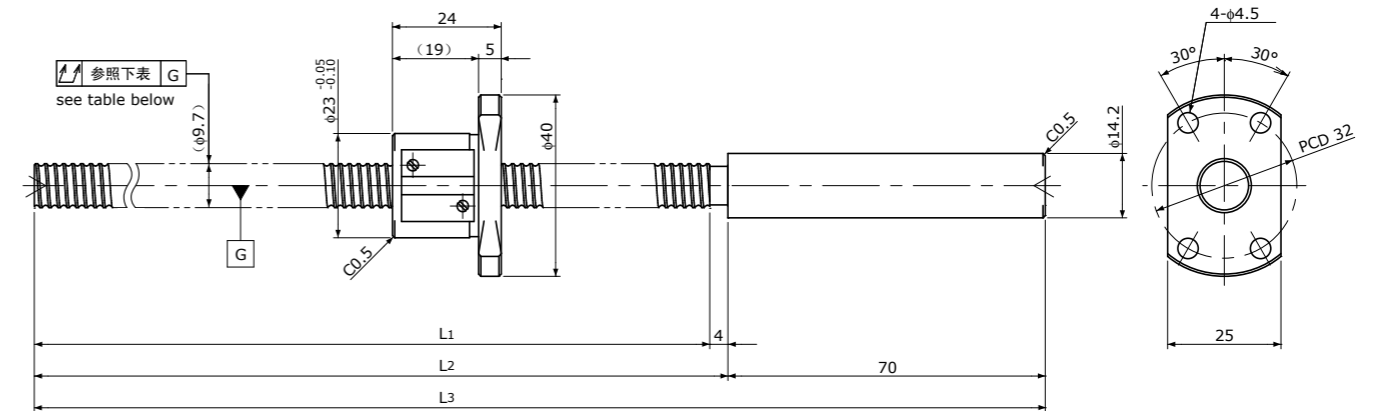
Standard products in stock SRT series  
标准库存品 SRT系列SRT1002 | Shaft dia. (轴径)  $\phi 10$  Lead (导程) 2mm | Ct7&Ct10

Ball Screw Specifications		主要技术参数
Ball size 钢珠直径		$\phi 1.5875$
Number of thread 螺纹条数		1
Thread direction 螺纹旋向		Right 右旋
Shaft root dia. 丝杠轴底径		$\phi 8.6$
Number of circuit 循环数		3.7×1
Material 材质	Shaft 轴 Nut 螺母	SCM415H+SUS303 SCM415H
Surface hardness 螺纹部表面硬度		HRC58~ (Thread area)
Anti-rust treatment 防锈处理		Anti-rust oil 防锈油

End-journal profile 轴端加工形状		Supported-side 支撑侧	Fixed-side 固定侧
A-type	B-type	C-type	
Support-unit Recommendation 推荐的支架组件		Supported-side 支撑侧	Fixed-side 固定侧
		MSU-8CS/8GS, EF8	MSU-8C/8G, EK8
D-type: Other than the above. 上述以外的形状			

Ball Screw Model 滚珠丝杠型号	Travel 行程	Grade 精度	Shaft length 丝杠轴长度			Lead accuracy 导程精度		Total Run-out 全跳动	Axial play 轴向间隙	Preload Torque 预压扭矩 Nm	Basic Load Rating 基本额定负载 N	
			L1	L2	L3	Travel deviation 代表移动量误差 $e_p$	Variation 波动 $V_{300}$				Dynamic 额定动负载 Ca	Static 额定静负载 Coa
SRT1002-196R270C7	170	Ct7	196	200	270	$\pm 0.03$	—	0.080	~0.020	—	2700	5300
SRT1002-396R470C7	370	Ct7	396	400	470	$\pm 0.06$	0.05	0.120				
SRT1002-196R270C10	170	Ct10	196	200	270	$\pm 0.13$	—	0.160	~0.050	—	2700	5300
SRT1002-396R470C10	370	Ct10	396	400	470	$\pm 0.27$	0.21	0.240				

Note) Please refer to p-A287 for order code of end-journal machining. 注) 追加加工的公称型号指定方式请参照p-A287.

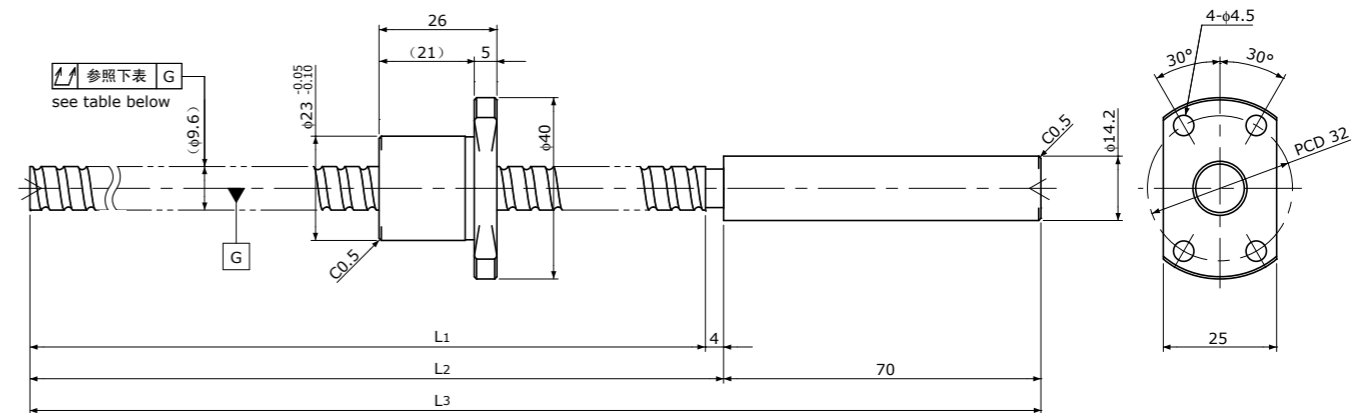
Standard products in stock SRT series  
标准库存品 SRT系列SRT1005 | Shaft dia.(轴径)  $\phi 10$  Lead(导程) 5mm | Ct7&Ct10

Unit(单位): mm

Ball Screw Specifications 主要技术参数		End-journal profile 轴端加工形状	Supported-side 支撑侧	Fixed-side 固定侧
Ball size 钢珠直径	$\phi 2.0$	A-type	B-type	C-type
Number of thread 螺纹条数	1			
Thread direction 螺纹旋向	Right 右旋			
Shaft root dia. 丝杠轴底径	$\phi 8.2$	<p>L4: Thread length after end-journal machining. 追加加工后的螺纹部长度 L5: Total length after end-journal machining. 追加加工后的总长</p>		
Number of circuit 循环数	2.7 x 1	<p>Support-unit Recommendation 推荐的支架组件</p> <p>Supported-side 支撑侧 : MSU-8CS/8GS, EF8 Fixed-side 固定侧 : MSU-8C/8G, EK8</p>		
Material 材质	Shaft 轴: SCM415H+SUS303 Nut 螺母: SCM415H	<p>D-type: Other than the above. 上述以外的形状</p>		
Surface hardness 螺纹部表面硬度	HRC58~ (Thread area)	<p>Anti-rust treatment 防锈处理: Anti-rust oil 防锈油</p>		

Unit(单位): mm

Ball Screw Specifications 主要技术参数		End-journal profile 轴端加工形状	Supported-side 支撑侧	Fixed-side 固定侧
Ball size 钢珠直径	$\phi 1.2$	A-type	B-type	C-type
Number of thread 螺纹条数	1			
Thread direction 螺纹旋向	Right 右旋			
Shaft root dia. 丝杠轴底径	$\phi 9.0$	<p>L4: Thread length after end-journal machining. 追加加工后的螺纹部长度 L5: Total length after end-journal machining. 追加加工后的总长</p>		
Number of circuit 循环数	1 x 3	<p>Support-unit Recommendation 推荐的支架组件</p> <p>Supported-side 支撑侧 : MSU-8CS/8GS, EF8 Fixed-side 固定侧 : MSU-8C/8G, EK8</p>		
Material 材质	Shaft 轴: S55C+SUS303 Nut 螺母: SCM415H	<p>D-type: Other than the above. 上述以外的形状</p>		
Surface hardness 螺纹部表面硬度	HRC58~ (Thread area)	<p>Anti-rust treatment 防锈处理: Anti-rust oil 防锈油</p>		

D-type: Other than the above. 上述以外的形状

Unit(单位): mm

Ball Screw Model 滚珠丝杠型号	Travel 行程	Grade 精度	Shaft length 丝杠轴长度			Lead accuracy 导程精度		Total Run-out 全跳动	Axial play 轴向间隙	Preload Torque 预压扭矩 Nm	Basic Load Rating 基本额定负载 N	
			L1	L2	L3	Travel deviation 代表移动量误差 $e_p$	Variation 波动 $V_{300}$				Dynamic 额定动负载 $C_a$	Static 额定静负载 $C_oa$
SRT1005-196R270C7	170	Ct7	196	200	270	$\pm 0.03$	—	0.080	~0.020	—	3000	5200
SRT1005-396R470C7	370	Ct7	396	400	470	$\pm 0.06$	0.05	0.120	~0.020	—	3000	5200
SRT1005-196R270C10	170	Ct10	196	200	270	$\pm 0.13$	—	0.160	~0.050	—	3000	5200
SRT1005-396R470C10	370	Ct10	396	400	470	$\pm 0.27$	0.21	0.240	~0.050	—	3000	5200

Note) Please refer to p-A287 for order code of end-journal machining. 注) 追加加工的公称型号指定方式请参照p-A287.

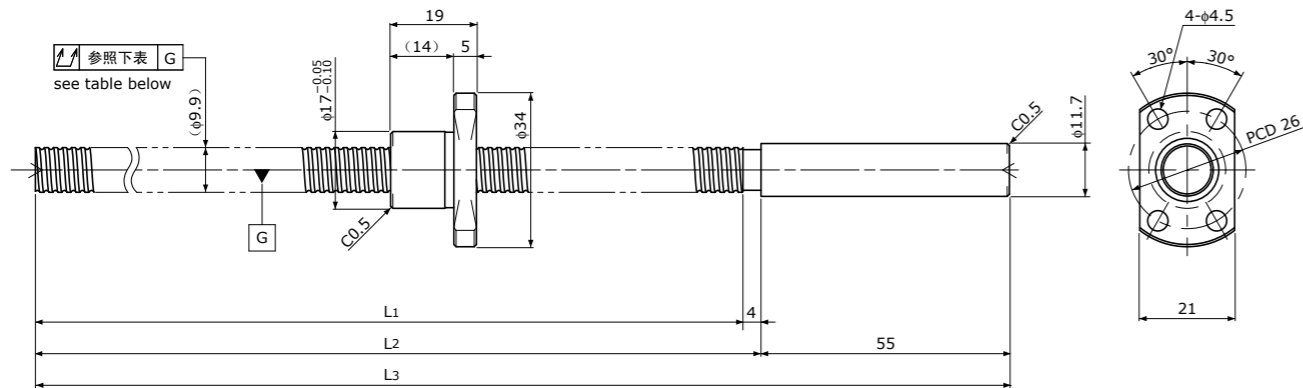
Standard products in stock SRT series  
标准库存品 SRT系列SRT1002K | Compact Nut / 紧凑型螺母  
Shaft dia.(轴径)  $\phi 10$  Lead(导程) 2mm | Ct7&Ct10

Unit(单位): mm

Ball Screw Specifications 主要技术参数		End-journal profile 轴端加工形状	Supported-side 支撑侧	Fixed-side 固定侧
Ball size 钢珠直径	$\phi 1.2$	A-type	B-type	C-type
Number of thread 螺纹条数	1			
Thread direction 螺纹旋向	Right 右旋			
Shaft root dia. 丝杠轴底径	$\phi 9.0$	<p>L4: Thread length after end-journal machining. 追加加工后的螺纹部长度 L5: Total length after end-journal machining. 追加加工后的总长</p>		
Number of circuit 循环数	1 x 3	<p>Support-unit Recommendation 推荐的支架组件</p> <p>Supported-side 支撑侧 : MSU-8CS/8GS, EF8 Fixed-side 固定侧 : MSU-8C/8G, EK8</p>		
Material 材质	Shaft 轴: S55C+SUS303 Nut 螺母: SCM415H	<p>D-type: Other than the above. 上述以外的形状</p>		
Surface hardness 螺纹部表面硬度	HRC58~ (Thread area)	<p>Anti-rust treatment 防锈处理: Anti-rust oil 防锈油</p>		

D-type: Other than the above. 上述以外的形状

Unit(单位): mm

Ball Screw Model 滚珠丝杠型号	Travel 行程	Grade 精度	Shaft length 丝杠轴长度			Lead accuracy 导程精度		Total Run-out 全跳动	Axial play 轴向间隙	Preload Torque 预压扭矩 Nm	Basic Load Rating 基本额定负载 N	
			L1	L2	L3	Travel deviation 代表移动量误差 $e_p$	Variation 波动 $V_{300}$				Dynamic 额定动负载 $C_a$	Static 额定静负载 $C_oa$
SRT1002K-201R260C7	175	Ct7	201	205	260	$\pm 0.03$	—	0.080	~0.020	—	1450	3000
SRT1002K-201R260C10	175	Ct10	201	205	260	$\pm 0.14$	—	0.160	~0.050	—	1450	3000

Note) Please refer to p-A287 for order code of end-journal machining. 注) 追加加工的公称型号指定方式请参照p-A287.

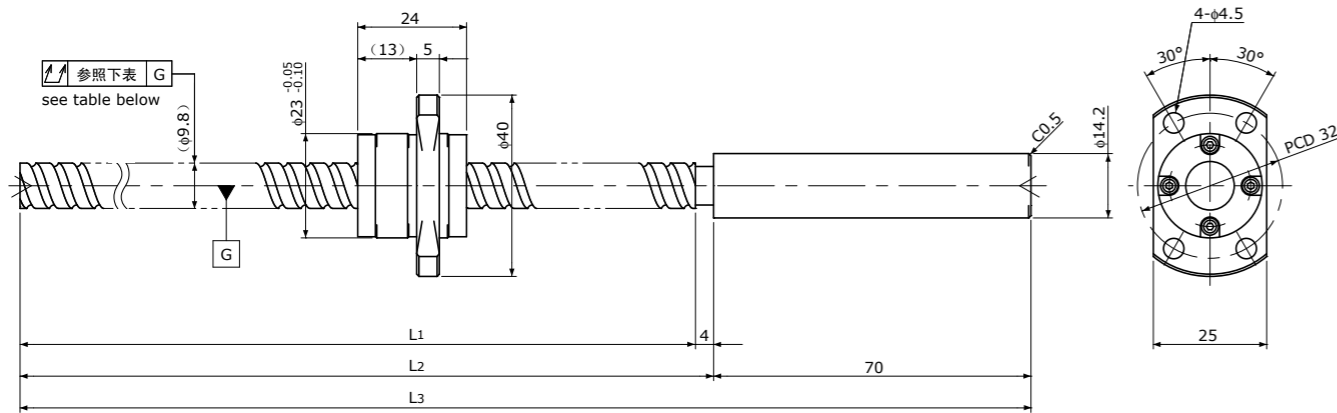
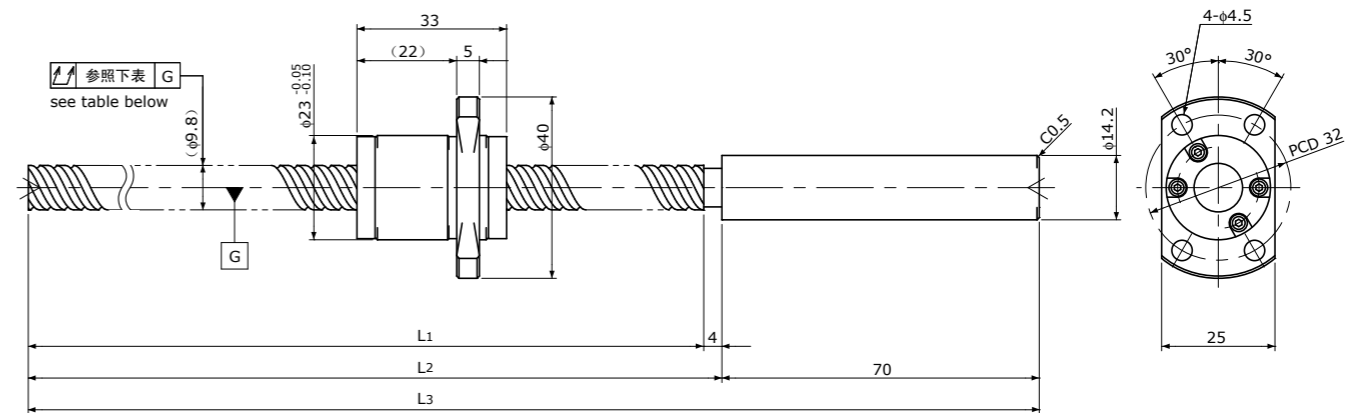

Standard products in stock SRT series  
标准库存品 SRT系列SRT1010 | Shaft dia.(轴径)  $\phi 10$  Lead(导程) 10mm | Ct7&Ct10Standard products in stock SRT series  
标准库存品 SRT系列SRT1015 | Shaft dia.(轴径)  $\phi 10$  Lead(导程) 15mm | Ct7&Ct10

Unit(单位): mm

Ball Screw Specifications 主要技术参数		End-journal profile 轴端加工形状 Supported-side 支撑侧			Fixed-side 固定侧
Ball size 钢珠直径	$\phi 2.0$	A-type	B-type	C-type	
Number of thread 螺纹条数	2				
Thread direction 螺纹旋向	Right 右旋	<p>L4: Thread length after end-journal machining. 追加加工后的螺纹部长度 L5: Total length after end-journal machining. 追加加工后的总长</p>			
Shaft root dia. 丝杠轴底径	$\phi 8.4$	<p>Support-unit Recommendation 推荐的支架组件</p> <p>Supported-side 支撑侧 : MSU-8CS/8GS, EF8 Fixed-side 固定侧 : MSU-8C/8G, EK8</p>			
Number of circuit 循环数	1.6×2	D-type: Other than the above. 上述以外的形状			
Material 材质	Shaft 轴: SCM415H+SUS303 Nut 螺母: SCM415H				
Surface hardness 螺纹部表面硬度	HRC58~ (Thread area)				
Anti-rust treatment 防锈处理	Anti-rust oil 防锈油				

Unit(单位): mm

Ball Screw Model 滚珠丝杠型号	Travel 行程	Grade 精度	Shaft length 丝杠轴长度			Lead accuracy 导程精度		Total Run-out 全跳动	Axial play 轴向间隙	Preload Torque 预压扭矩 Nm	Basic Load Rating 基本额定负载 N	
			L1	L2	L3	Travel deviation 代表移动量误差 $e_p$	Variation 波动 $V_{300}$				Dynamic 额定动负载 $C_a$	Static 额定静负载 $C_oa$
SRT1010-196R270C7	170	Ct7	196	200	270	$\pm 0.03$	—	0.080	~0.020	—	3300	5900
SRT1010-396R470C7	370	Ct7	396	400	470	$\pm 0.06$	0.05	0.120				
SRT1010-196R270C10	170	Ct10	196	200	270	$\pm 0.13$	—	0.160	~0.050	—	3300	5900
SRT1010-396R470C10	370	Ct10	396	400	470	$\pm 0.27$	0.21	0.240				

Note) Please refer to p-A287 for order code of end-journal machining. 注) 追加加工的公称型号指定方式请参照p-A287.

Unit(单位): mm

Ball Screw Specifications 主要技术参数		End-journal profile 轴端加工形状 Supported-side 支撑侧			Fixed-side 固定侧
Ball size 钢珠直径	$\phi 2.0$	A-type	B-type	C-type	
Number of thread 螺纹条数	2				
Thread direction 螺纹旋向	Right 右旋	<p>L4: Thread length after end-journal machining. 追加加工后的螺纹部长度 L5: Total length after end-journal machining. 追加加工后的总长</p>			
Shaft root dia. 丝杠轴底径	$\phi 8.4$	<p>Support-unit Recommendation 推荐的支架组件</p> <p>Supported-side 支撑侧 : MSU-8CS/8GS, EF8 Fixed-side 固定侧 : MSU-8C/8G, EK8</p>			
Number of circuit 循环数	1.6×2	D-type: Other than the above. 上述以外的形状			
Material 材质	Shaft 轴: SCM415H+SUS303 Nut 螺母: SCM415H				
Surface hardness 螺纹部表面硬度	HRC58~ (Thread area)				
Anti-rust treatment 防锈处理	Anti-rust oil 防锈油				

Unit(单位): mm

Ball Screw Model 滚珠丝杠型号	Travel 行程	Grade 精度	Shaft length 丝杠轴长度			Lead accuracy 导程精度		Total Run-out 全跳动	Axial play 轴向间隙	Preload Torque 预压扭矩 Nm	Basic Load Rating 基本额定负载 N	
			L1	L2	L3	Travel deviation 代表移动量误差 $e_p$	Variation 波动 $V_{300}$				Dynamic 额定动负载 $C_a$	Static 额定静负载 $C_oa$
SRT1015-196R270C7	160	Ct7	196	200	270	$\pm 0.03$	—	0.080	~0.020	—	3300	6400
SRT1015-396R470C7	360	Ct7	396	400	470	$\pm 0.06$	0.05	0.120				
SRT1015-196R270C10	160	Ct10	196	200	270	$\pm 0.13$	—	0.160	~0.050	—	3300	6400
SRT1015-396R470C10	360	Ct10	396	400	470	$\pm 0.27$	0.21	0.240				

Note) Please refer to p-A287 for order code of end-journal machining. 注) 追加加工的公称型号指定方式请参照p-A287.

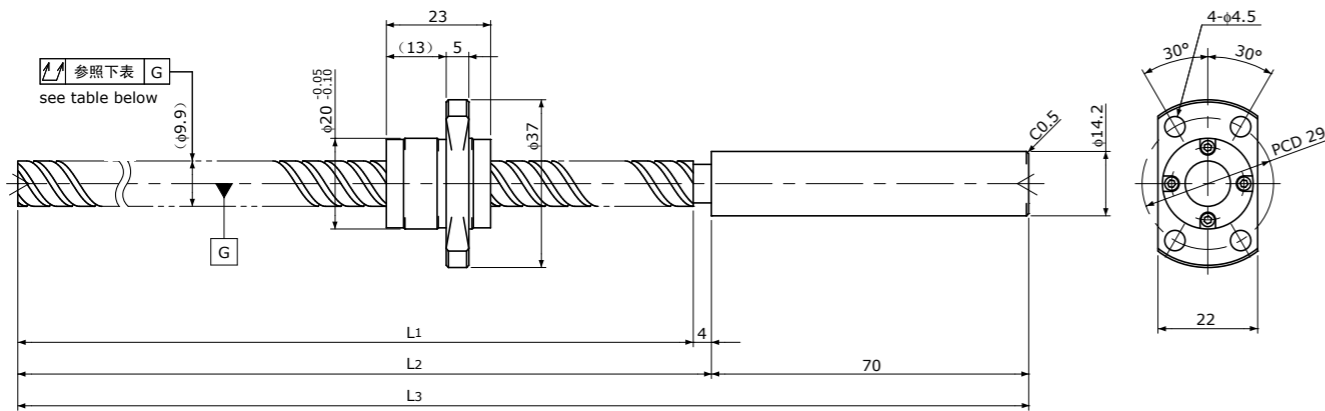
Standard products in stock SRT series  
标准库存品 SRT系列SRT1020 | Shaft dia. (轴径)  $\phi 10$  Lead (导程) 20mm | Ct7&Ct10

Ball Screw Specifications 主要技术参数		Unit (单位) : mm
Ball size 钢珠直径	$\phi 1.5875$	
Number of thread 螺纹条数	4	
Thread direction 螺纹旋向	Right 右旋	
Shaft root dia. 丝杠轴底径	$\phi 8.7$	
Number of circuit 循环数	0.7×4	
Material 材质	Shaft 轴: SCM415H+SUS303 Nut 螺母: SCM415H	
Surface hardness 螺纹部表面硬度	HRC58~ (Thread area)	
Anti-rust treatment 防锈处理	Anti-rust oil 防锈油	

End-journal profile 轴端加工形状	Supported-side 支撑侧	Fixed-side 固定侧
A-type	B-type	C-type
L4: Thread length after end-journal machining. 追加加工后的螺纹部长度 L5: Total length after end-journal machining. 追加加工后的总长		
Support-unit Recommendation 推荐的支架组件		Supported-side 支撑侧 : MSU-8CS/8GS, EF8 Fixed-side 固定侧 : MSU-8C/8G, EK8
D-type: Other than the above. 上述以外的形状		

Unit (单位) : mm

Ball Screw Model 滚珠丝杠型号	Travel 行程	Grade 精度	Shaft length 丝杠轴长度			Lead accuracy 导程精度		Total Run-out 全跳动	Axial play 轴向间隙	Preload Torque 预压扭矩 Nm	Basic Load Rating 基本额定负载 N	
			L1	L2	L3	Travel deviation 代表移动量误差 $e_p$	Variation 波动 $V_{300}$				Dynamic 额定动负载 Ca	Static 额定静负载 Coa
SRT1020-196R270C7	170	Ct7	196	200	270	$\pm 0.03$	—	0.080	~0.020	—	2100	4000
SRT1020-396R470C7	370	Ct7	396	400	470	$\pm 0.06$	0.05	0.120				
SRT1020-196R270C10	170	Ct10	196	200	270	$\pm 0.13$	—	0.160	~0.050	—	2100	4000
SRT1020-396R470C10	370	Ct10	396	400	470	$\pm 0.27$	0.21	0.240				

Note) Please refer to p-A287 for order code of end-journal machining. 注) 追加加工的公称型号指定方式请参照p-A287.

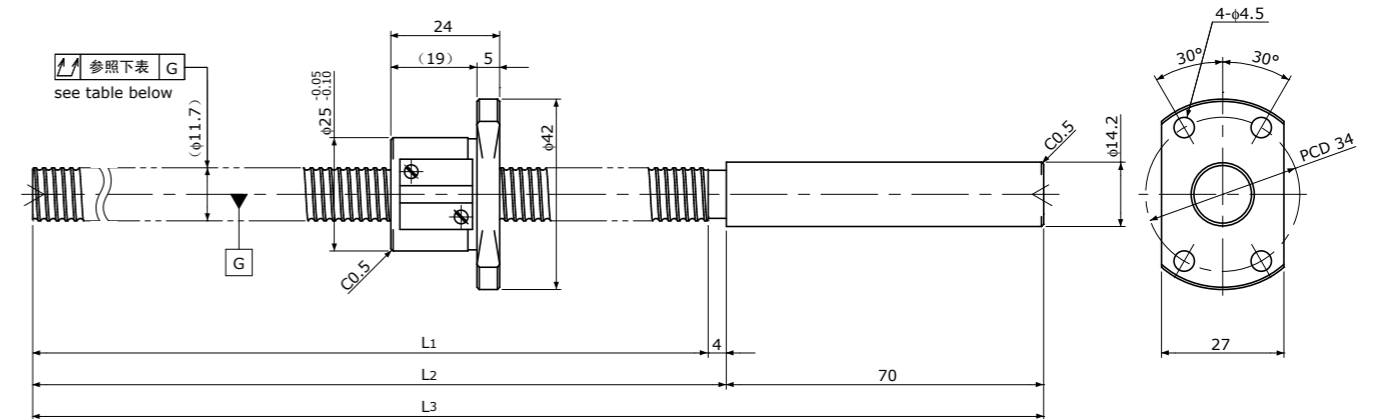
Standard products in stock SRT series  
标准库存品 SRT系列SRT1202 | Shaft dia. (轴径)  $\phi 12$  Lead (导程) 2mm | Ct7&Ct10

Ball Screw Specifications 主要技术参数		Unit (单位) : mm
Ball size 钢珠直径	$\phi 1.5875$	
Number of thread 螺纹条数	1	
Thread direction 螺纹旋向	Right 右旋	
Shaft root dia. 丝杠轴底径	$\phi 10.6$	
Number of circuit 循环数	3.7×1	
Material 材质	Shaft 轴: SCM415H+SUS303 Nut 螺母: SCM415H	
Surface hardness 螺纹部表面硬度	HRC58~ (Thread area)	
Anti-rust treatment 防锈处理	Anti-rust oil 防锈油	

End-journal profile 轴端加工形状	Supported-side 支撑侧	Fixed-side 固定侧
A-type	B-type	C-type
L4: Thread length after end-journal machining. 追加加工后的螺纹部长度 L5: Total length after end-journal machining. 追加加工后的总长		
Support-unit Recommendation 推荐的支架组件		Supported-side 支撑侧 : EF10 Fixed-side 固定侧 : EK10
D-type: Other than the above. 上述以外的形状		

Unit (单位) : mm

Ball Screw Model 滚珠丝杠型号	Travel 行程	Grade 精度	Shaft length 丝杠轴长度			Lead accuracy 导程精度		Total Run-out 全跳动	Axial play 轴向间隙	Preload Torque 预压扭矩 Nm	Basic Load Rating 基本额定负载 N	
			L1	L2	L3	Travel deviation 代表移动量误差 $e_p$	Variation 波动 $V_{300}$				Dynamic 额定动负载 Ca	Static 额定静负载 Coa
SRT1202-196R270C7	170	Ct7	196	200	270	$\pm 0.03$	—	0.080	~0.020	—	3000	6400
SRT1202-396R470C7	370	Ct7	396	400	470	$\pm 0.06$	0.05	0.080				
SRT1202-196R270C10	170	Ct10	196	200	270	$\pm 0.13$	—	0.160	~0.050	—	3000	6400
SRT1202-396R470C10	370	Ct10	396	400	470	$\pm 0.27$	0.21	0.160				

Note) Please refer to p-A287 for order code of end-journal machining. 注) 追加加工的公称型号指定方式请参照p-A287.

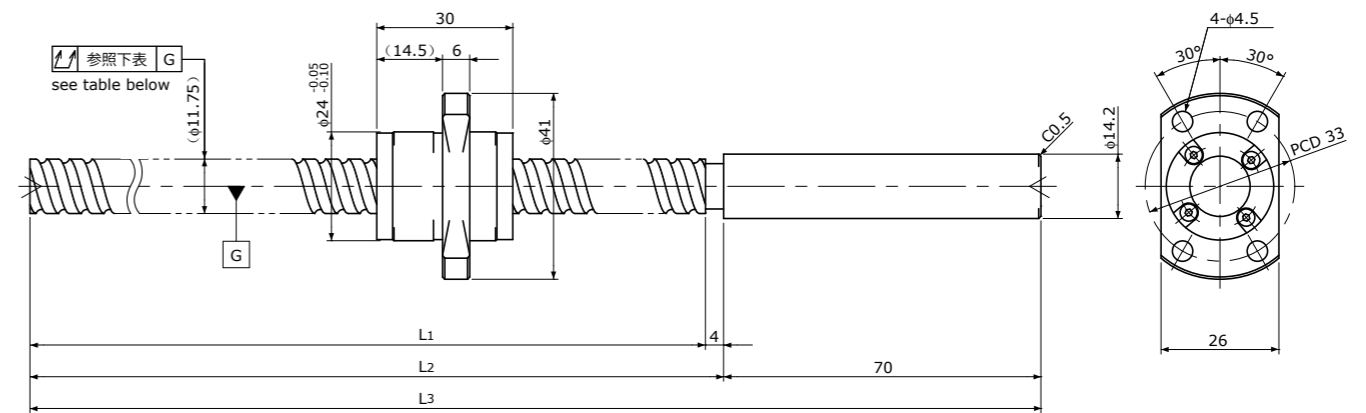
Standard products in stock SRT series  
标准库存品 SRT系列SRT1210 | Shaft dia. (轴径)  $\phi 12$  Lead (导程) 10mm | Ct7&Ct10

Unit (单位) : mm

Ball Screw Specifications 主要技术参数	
Ball size 钢珠直径	$\phi 2.381$
Number of thread 螺纹条数	2
Thread direction 螺纹旋向	Right 右旋
Shaft root dia. 丝杠轴底径	$\phi 10.2$
Number of circuit 循环数	1.7×2
Material 材质	Shaft 轴 SCM415H+SUS303 Nut 螺母 SCM415H
Surface hardness 螺纹部表面硬度	HRC58~ (Thread area)
Anti-rust treatment 防锈处理	Anti-rust oil 防锈油

End-journal profile 轴端加工形状		Supported-side 支撑侧		Fixed-side 固定侧	
A-type	B-type	C-type			
L4: Thread length after end-journal machining. 追加加工后的螺纹部长度		L5: Total length after end-journal machining. 追加加工后的总长			
Support-unit Recommendation 推荐的支架组件		Supported-side 支撑侧 : EF10		Fixed-side 固定侧 : EK10	
D-type: Other than the above. 上述以外的形状					

Unit (单位) : mm

Ball Screw Model 滚珠丝杠型号	Travel 行程	Grade 精度	Shaft length 丝杠轴长度			Lead accuracy 导程精度		Total Run-out 全跳动	Axial play 轴向间隙	Preload Torque 预压扭矩 Nm	Basic Load Rating 基本额定负载 N	
			L1	L2	L3	Travel deviation 代表移动量误差 $e_p$	Variation 波动 $V_{300}$				Dynamic 额定动负载 $C_a$	Static 额定静负载 $C_oa$
SRT1210-196R270C7	165	Ct7	196	200	270	$\pm 0.03$	—	0.080	~0.020	—	5100	9800
SRT1210-396R470C7	365	Ct7	396	400	470	$\pm 0.06$	0.05	0.080	—	—	—	—
SRT1210-196R270C10	165	Ct10	196	200	270	$\pm 0.13$	—	0.160	~0.050	—	—	—
SRT1210-396R470C10	365	Ct10	396	400	470	$\pm 0.27$	0.21	0.160	—	—	—	—

Note) Please refer to p-A287 for order code of end-journal machining. 注) 追加加工的公称型号指定方式请参照p-A287.

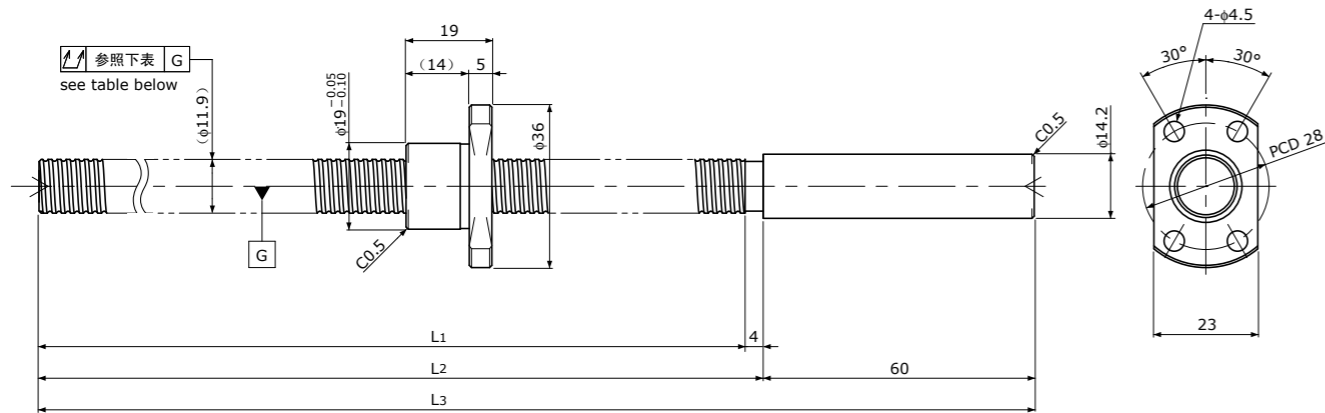
Standard products in stock SRT series  
标准库存品 SRT系列SRT1202K | Compact Nut / 紧凑型螺母  
Shaft dia. (轴径)  $\phi 12$  Lead (导程) 2mm | Ct7&Ct10

Unit (单位) : mm

Ball Screw Specifications 主要技术参数		End-journal profile 轴端加工形状		Supported-side 支撑侧		Fixed-side 固定侧	
A-type	B-type	C-type					
L4: Thread length after end-journal machining. 追加加工后的螺纹部长度		L5: Total length after end-journal machining. 追加加工后的总长					
Support-unit Recommendation 推荐的支架组件		Supported-side 支撑侧 : EF10		Fixed-side 固定侧 : EK10			
D-type: Other than the above. 上述以外的形状							

Unit (单位) : mm

Ball Screw Model 滚珠丝杠型号	Travel 行程	Grade 精度	Shaft length 丝杠轴长度			Lead accuracy 导程精度		Total Run-out 全跳动	Axial play 轴向间隙	Preload Torque 预压扭矩 Nm	Basic Load Rating 基本额定负载 N	
			L1	L2	L3	Travel deviation 代表移动量误差 $e_p$	Variation 波动 $V_{300}$				Dynamic 额定动负载 $C_a$	Static 额定静负载 $C_oa$
SRT1202K-271R335C7	245	Ct7	271	275	335	$\pm 0.04$	—	0.080	~0.020	—	1600	3700
SRT1202K-271R335C10	245	Ct10	271	275	335	$\pm 0.19$	—	0.160	~0.050	—	—	—

Note) Please refer to p-A287 for order code of end-journal machining. 注) 追加加工的公称型号指定方式请参照p-A287.





Standard products in stock SSRT series  
标准库存品 SSRT系列

SSRT0802 | Stainless 不锈钢  
Shaft dia. (轴径)  $\phi 8$  Lead (导程) 2mm | Ct7&Ct10

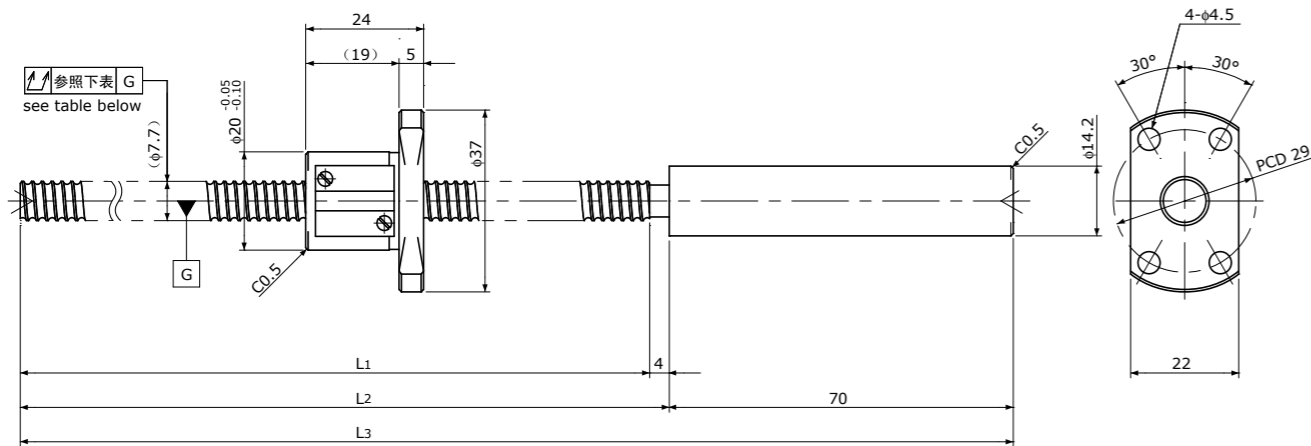

Standard products in stock SSRT series  
标准库存品 SSRT系列

SSRT1002 | Stainless 不锈钢  
Shaft dia. (轴径)  $\phi 10$  Lead (导程) 2mm | Ct7&Ct10

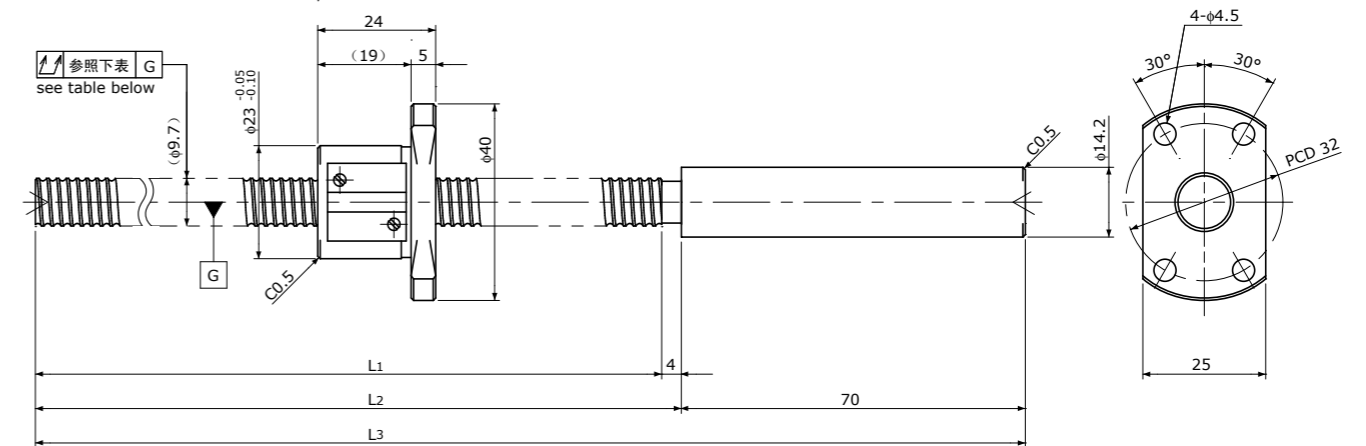

Unit (单位): mm

Ball Screw Specifications 主要技术参数		End-journal profile 轴端加工形状 Supported-side 支撑侧			Fixed-side 固定侧
Ball size 钢球直径	$\phi 1.5875$	A-type	B-type	C-type	
Number of thread 螺纹条数	1				
Thread direction 螺纹旋向	Right 右旋	<p>L4: Thread length after end-journal machining. 追加加工后的螺纹部长度 L5: Total length after end-journal machining. 追加加工后的总长</p>			
Shaft root dia. 丝杠轴底径	$\phi 6.6$	<p>Support-unit Recommendation 推荐的支架组件</p> <p>Supported-side 支撑侧 : MSU-6CS/6GS, EF6 Fixed-side 固定侧 : MSU-6C/6G, EK6</p>			
Number of circuit 循环数	3.7 × 1	D-type: Other than the above. 上述以外的形状			
Material 材质	Shaft 轴: SUS440C+SUS303 Nut 螺母: SUS440C				
Surface hardness 螺纹部表面硬度	HRC55~ (Thread area)				
Anti-rust treatment 防锈处理	Anti-rust oil 防锈油				

Unit (单位): mm

Ball Screw Model 滚珠丝杠型号	Travel 行程	Grade 精度	Shaft length 丝杠轴长度			Lead accuracy 导程精度		Total Run-out 全跳动	Axial play 轴向间隙	Preload Torque 预压扭矩 Nm	Basic Load Rating 基本额定负载 N	
			L1	L2	L3	Travel deviation 代表移动量误差 $e_p$	Variation 波动 $V_{300}$				Dynamic 额定动负载 $C_a$	Static 额定静负载 $C_oa$
SSRT0802-196R270C7	170	Ct7	196	200	270	$\pm 0.03$	—	0.080	~0.020	—	1950	3100
SSRT0802-356R430C7	330	Ct7	356	360	430	$\pm 0.06$	0.05	0.120				
SSRT0802-196R270C10	170	Ct10	196	200	270	$\pm 0.13$	—	0.160	~0.050	—	1950	3100
SSRT0802-356R430C10	330	Ct10	356	360	430	$\pm 0.24$	0.21	0.240				

Note) Please refer to p-A287 for order code of end-journal machining. 注) 追加加工的公称型号指定方式请参照p-A287.

Unit (单位): mm

Ball Screw Specifications 主要技术参数		End-journal profile 轴端加工形状 Supported-side 支撑侧			Fixed-side 固定侧
Ball size 钢球直径	$\phi 1.5875$	A-type	B-type	C-type	
Number of thread 螺纹条数	1				
Thread direction 螺纹旋向	Right 右旋	<p>L4: Thread length after end-journal machining. 追加加工后的螺纹部长度 L5: Total length after end-journal machining. 追加加工后的总长</p>			
Shaft root dia. 丝杠轴底径	$\phi 8.6$	<p>Support-unit Recommendation 推荐的支架组件</p> <p>Supported-side 支撑侧 : MSU-8CS/8GS, EF8 Fixed-side 固定侧 : MSU-8C/8G, EK8</p>			
Number of circuit 循环数	3.7 × 1	D-type: Other than the above. 上述以外的形状			
Material 材质	Shaft 轴: SUS440C+SUS303 Nut 螺母: SUS440C				
Surface hardness 螺纹部表面硬度	HRC55~ (Thread area)				
Anti-rust treatment 防锈处理	Anti-rust oil 防锈油				

Unit (单位): mm

Ball Screw Model 滚珠丝杠型号	Travel 行程	Grade 精度	Shaft length 丝杠轴长度			Lead accuracy 导程精度		Total Run-out 全跳动	Axial play 轴向间隙	Preload Torque 预压扭矩 Nm	Basic Load Rating 基本额定负载 N	
			L1	L2	L3	Travel deviation 代表移动量误差 $e_p$	Variation 波动 $V_{300}$				Dynamic 额定动负载 $C_a$	Static 额定静负载 $C_oa$
SSRT1002-196R270C7	170	Ct7	196	200	270	$\pm 0.03$	—	0.080	~0.020	—	2200	4000
SSRT1002-396R470C7	370	Ct7	396	400	470	$\pm 0.06$	0.05	0.120				
SSRT1002-196R270C10	170	Ct10	196	200	270	$\pm 0.13$	—	0.160	~0.050	—	2200	4000
SSRT1002-396R470C10	370	Ct10	396	400	470	$\pm 0.27$	0.21	0.240				

Note) Please refer to p-A287 for order code of end-journal machining. 注) 追加加工的公称型号指定方式请参照p-A287.