

Rolled Ball Screws 冷轧滚珠丝杠

Sleeve type Single Nut 套筒型单螺母

Backlash type 齿侧间隙型

- 也可生产对轴端直径进行了加粗设计的台阶型冷轧加工（下图），详情请垂询本公司。（轴端直径φ12以下）
- Rolled Ball Screws with integrated journal are available (φ12 or less only), which have larger diameter than threaded area shown below.

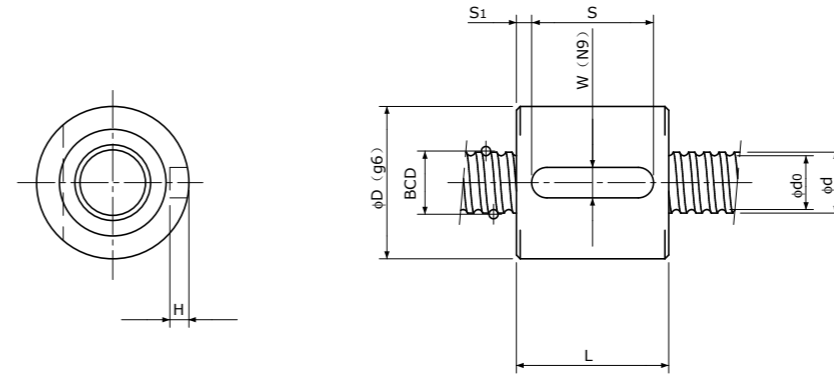
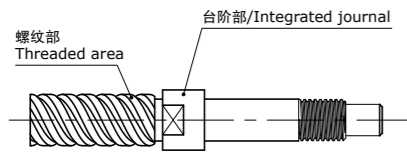

Unit(单位): mm

Ball Nut Model number 螺母型号	Shaft nominal dia. 丝杠轴公称外径 d	Lead 导程	Ball size 丝杠直径	BCD 钢珠中心直径	Lead angle 导程角	Root dia. 底径 d ₀	Number of Circuit 循环数	Basic Load Rating 基本额定负载 N		Nut Rigidity 螺母刚性 N/∇m	Nut dimension 螺母尺寸						Ball Nut Model number 螺母型号	
								Dynamic 额定动负载 Ca	Static 额定静负载 Coa		D	L	W	H	S	S ₁		
BSR 0401	4	1	0.8	4.15	4°23'	3.3	3.7×1	560	790	54		11	14	3	1.8	8	3	BSR 0401
BSR 0402	4	2	0.8	4.15	8°43'	3.3	2.7×1	420	570	39		11	16	3	1.8	8	4	BSR 0402
BSR 0504	5	4	0.8	5.15	13°53'	4.3	2.7×1	470	720	47		12	22	3	1.8	12	5	BSR 0504
BSR 0601 **	6	1	0.8	6.15	2°58'	5.3	3.7×1	680	1200	75		13	14	3	1.8	10	2	BSR 0601 **
BSR 0602	6	2	1.0	6.20	5°52'	5.1	2.7×1	750	1200	58		15	15	3	1.8	10	2.5	BSR 0602
BSR 0801 **	8	1	0.8	8.15	2°15'	7.3	3.7×1	780	1650	95		16	14	3	1.8	10	2	BSR 0801 **
BSR 0802 **	8	2	1.5875	8.30	4°23'	6.6	3.7×1	2400	4100	111		20	20	4	2.5	16	2	BSR 0802 **
BSR 0802.5	8	2.5	1.5875	8.00	5°41'	6.3	2.7×1	1850	3000	80		16	16	3	1.8	8	4	BSR 0802.5
BSR 0805	8	5	1.5875	8.30	10°51'	6.6	2.7×1	1850	3000	82		18	28	4	2.5	20	4	BSR 0805

- 注1) 标准螺纹旋向为右旋。
 注2) 设计时，由于生产及组装螺母的关系，请使滚珠丝杠的两个轴端不超过丝杠轴底径。
 需要单侧台阶型时，请垂询本公司。
 注3) 标准螺母不带密封。
 不能安装密封，敬请注意。
 注4) 刚性
 表中的刚性值，是在相当于基本额定动负载Ca的30%的轴向负载作用时，根据轴向弹性位移量计算的理论值。
 轴向负载与上述条件不同时，可通过p-A823的公式计算。
 注5) 不锈钢冷轧滚珠丝杠
 螺母型号后带**者可提供不锈钢冷轧滚珠丝杠。

- Note 1) All models are Right-hand screw.
 Note 2) The diameter of the Screw Shaft both ends must be less than the Screw Shaft Root diameter, because of production and Nut assembly reason. If bigger end-journal than Shaft diameter is required, please consult KSS.
 Note 3) Ball Nut dimension is without seal at the both ends. All type of Ball Nuts cannot equip with seals.
 Note 4) Rigidity
 The Rigidity values shown in the table are theoretical values calculated from the amount of Elastic Displacement under the Axial load equivalent to 30% of the Basic Dynamic Load Rating Ca.
 For Axial load condition other than the above, see the formula in p-A823, you can calculate Rigidity using this formula.
 Note 5) Stainless Rolled Ball Screw
 Stainless Rolled Ball Screw is available for Ball Nut Model Number marked **.

Rolled Ball Screws 冷轧滚珠丝杠

Sleeve type Single Nut 套筒型单螺母

Backlash type 齿侧间隙型

- 也可生产对轴端直径进行了加粗设计的台阶型冷轧加工（下图），详情请垂询本公司。（轴端直径φ12以下）
- Rolled Ball Screws with integrated journal are available (φ12 or less only), which have larger diameter than threaded area shown below.

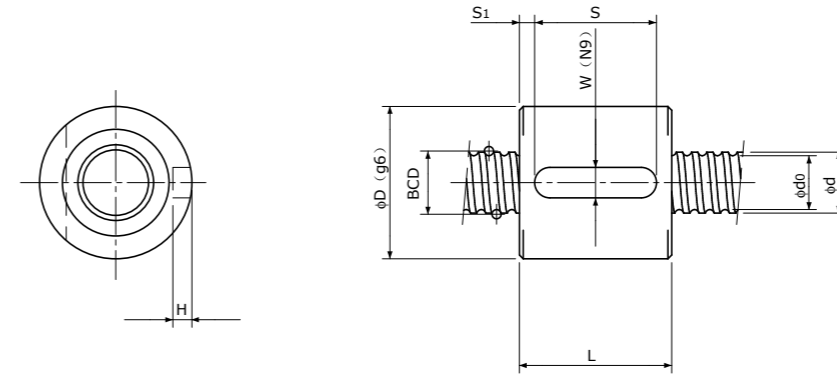
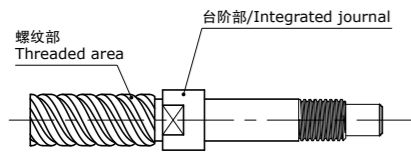

Unit(单位): mm

Ball Nut Model number 螺母型号	Shaft nominal dia. 丝杠轴公称外径 d	Lead 导程	Ball size 丝杠直径	BCD 钢珠中心直径	Lead angle 导程角	Root dia. 底径 d ₀	Number of Circuit 循环数	Basic Load Rating 基本额定负载 N		Nut Rigidity 螺母刚性 N/∅m	Nut dimension 螺母尺寸						Ball Nut Model number 螺母型号
								Dynamic 额定动负载 Ca	Static 额定静负载 Coa		D	L	W	H	S	S ₁	
BSR 1002 **	10	2	1.5875	10.30	3°32'	8.6	3.7×1	2700	5300	134	23	20	5	3	16	2.0	BSR 1002 **
BSR 1003	10	3	2.0	10.30	5°18'	8.2	3.7×1	3900	7200	140	24	26	5	3	20	3	BSR 1003
BSR 1004	10	4	2.0	10.30	7°03'	8.2	2.7×1	3000	5200	104	24	26	5	3	20	3	BSR 1004
BSR 1005	10	5	2.0	10.30	8°47'	8.2	2.7×1	3000	5200	103	23	26	5	3	16	5	BSR 1005
BSR 1006	10	6	2.0	10.30	10°30'	8.2	2.7×1	3000	5000	102	26	31	5	3	20	5.5	BSR 1006
BSR 1202	12	2	1.5875	12.30	2°58'	10.6	3.7×1	3000	6400	156	25	20	5	3	16	2	BSR 1202
BSR 1402	14	2	1.5875	14.30	2°33'	12.6	3.7×1	3200	7500	176	26	20	5	3	16	2	BSR 1402
BSR 1404	14	4	2.381	14.30	5°05'	11.8	3.7×1	5700	11600	187	30	31	5	3	25	3	BSR 1404

- 注1) 标准螺纹旋向为右旋。
 注2) 设计时，由于生产及组装螺母的关系，请使滚珠丝杠的两个轴端不超过丝杠轴底径。需要单侧台阶型时，请垂询本公司。
 注3) 标准螺母不带密封。不能安装密封，敬请注意。
 注4) 刚性
 表中的刚性值，是在相当于基本额定动负载Ca的30%的轴向负载作用时，根据轴向弹性位移量计算的理论值。轴向负载与上述条件不同时，可通过p-A823的公式计算。
 注5) 不锈钢冷轧滚珠丝杠
 螺母型号后带**者可提供不锈钢冷轧滚珠丝杠。

- Note 1) All models are Right-hand screw.
 Note 2) The diameter of the Screw Shaft both ends must be less than the Screw Shaft Root diameter, because of production and Nut assembly reason. If bigger end-journal than Shaft diameter is required, please consult KSS.
 Note 3) Ball Nut dimension is without seal at the both ends. All type of Ball Nuts cannot equip with seals.
 Note 4) Rigidity
 The Rigidity values shown in the table are theoretical values calculated from the amount of Elastic Displacement under the Axial load equivalent to 30% of the Basic Dynamic Load Rating Ca. For Axial load condition other than the above, see the formula in p-A823, you can calculate Rigidity using this formula.
 Note 5) Stainless Rolled Ball Screw
 Stainless Rolled Ball Screw is available for Ball Nut Model Number marked **.