

Standard products in stock SG series

# SG1015

Shaft dia.  $\phi 10$  Lead 15mm

C5

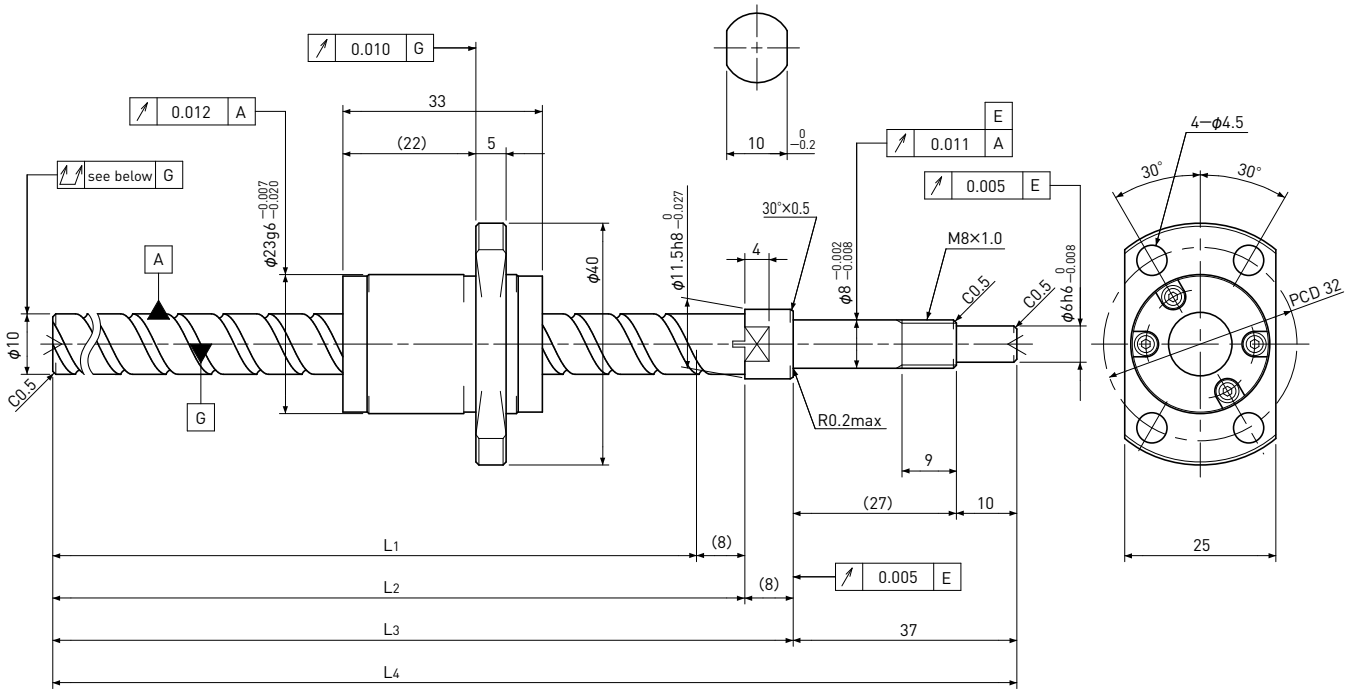

Unit: mm

Ball Screw Specifications	
Ball size	$\phi 2.0$
Number of thread	2
Thread direction	Right
Shaft root dia.	$\phi 8.4$
Number of circuit	1.6 × 2
Shaft, Nut material	SCM415H
Surface hardness	HRC58~62 (Thread area)
Anti-rust treatment	Anti-rust oil

### Supported-side end-journal profile

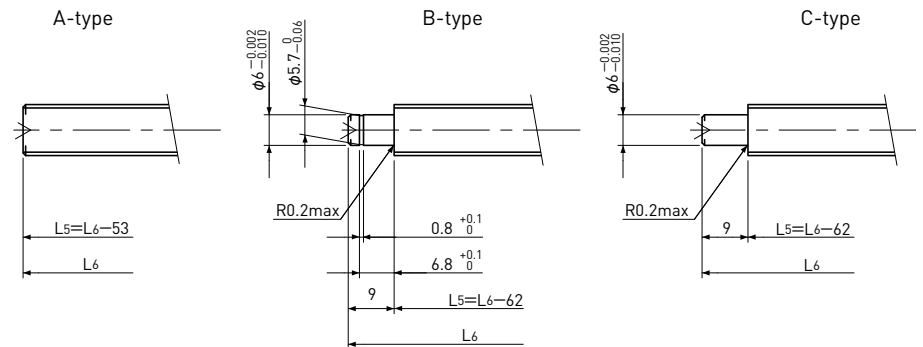

L5: Thread length after end-journal machining.  
L6: Total length after end-journal machining.

Support-unit Recommendation	Supported-side	MSU-8CS/8GS
	Fixed-side	MSU-8C/8G

D-type : Other than the above.

Unit: mm

Ball Screw Model	Travel	Grade	Shaft length				Lead accuracy		Total Run-out	Axial play	Preload Torque Nm	Basic Load Rating N	
			L <sub>1</sub>	L <sub>2</sub>	L <sub>3</sub>	L <sub>4</sub>	Travel deviation $e_p$	Variation $V_u$				Dynamic $C_a$	Static $C_{0a}$
SG1015-107R160C5	70	C5	107	115	123	160	$\pm 0.020$	0.018	0.040	~0.005	—	3300	6400
SG1015-257R310C5	220	C5	257	265	273	310	$\pm 0.023$	0.018	0.055				

Note) Please refer to page A206 for order code of end-journal machining.