

Precision Ball Screws

Sleeve type Single Nut

Backlash type/Preload type

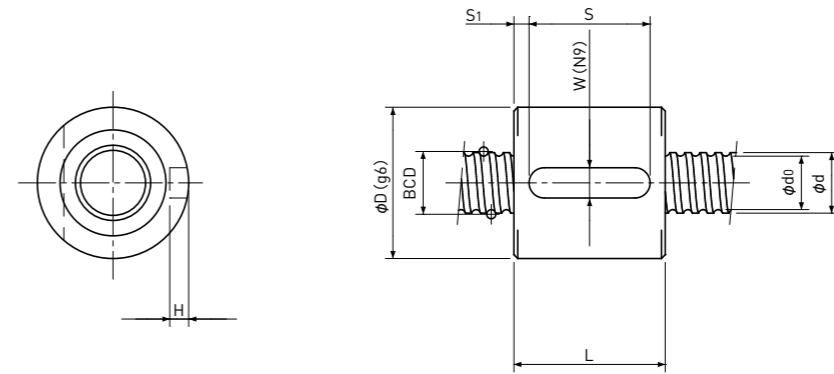

Unit: mm

Ball Nut Model number	Shaft nominal dia. d	Lead	Ball size	BCD	Lead angle	Root dia. d ₀	Number of Circuit	Basic Load Rating		Nut Rigidity N/μm	Nut dimension						Ball Nut Model number
								N			D	L	W	H	S	S ₁	
								Dynamic Ca	Static : Coa								
BS 1201 B	12	1	0.8	12.15	1°30'	11.3	3.7×1	910 / 570	2400 / 1200	131 / 110	22	14	4	2.5	10	2	BS 1201 B
BS 1202 B	12	2	1.5875	12.30	2°58'	10.6	3.7×1	3000 / 1900	6400 / 3200	156 / 132	25	20	5	3	16	2	BS 1202 B
BS 1202.5 B	12	2.5	1.5875	12.30	3°42'	10.6	3.7×1	3000 / 1850	6400 / 3200	156 / 130	26	22	5	3	16	3	BS 1202.5 B
BS 1203 B	12	3	2.0	12.30	4°26'	10.2	3.7×1	4300 / 2800	8700 / 4300	162 / 137	28	26	5	3	20	3	BS 1203 B
BS 1204 B	12	4	2.381	12.30	5°55'	9.8	3.7×1	5400 / 3400	10200 / 5100	165 / 139	28	31	5	3	25	3	BS 1204 B
BS 1205 A	12	5	2.381	12.30	7°22'	9.8	2.7×1	4100 / 2500	7400 / 3700	122 / 101	28	31	5	3	25	3	BS 1205 A
BS 1401 B	14	1	0.8	14.15	1°17'	13.3	3.7×1	960 / 610	2900 / 1450	148 / 124	26	16	5	3	10	3	BS 1401 B
BS 1402 B	14	2	1.5875	14.30	2°33'	12.6	3.7×1	3200 / 2000	7500 / 3800	176 / 148	26	20	5	3	16	2	BS 1402 B
BS 1402.5 B	14	2.5	1.5875	14.30	3°11'	12.6	3.7×1	3200 / 2000	7500 / 3700	176 / 148	28	22	5	3	16	3	BS 1402.5 B
BS 1403 B	14	3	2.0	14.30	3°49'	12.2	3.7×1	4600 / 2900	10100 / 5000	184 / 154	30	26	5	3	20	3	BS 1403 B
BS 1404 B	14	4	2.381	14.30	5°05'	11.8	3.7×1	5700 / 3600	11600 / 5800	187 / 157	30	31	5	3	25	3	BS 1404 B
BS 1405 B	14	5	2.381	14.30	6°21'	11.8	3.7×1	5700 / 3600	11600 / 5800	186 / 157	30	38	5	3	28	5	BS 1405 B

Note 1) The diameter of one of the Screw Shaft ends must be less than the Screw Shaft Root diameter, otherwise Ball Nut cannot be installed.

Note 2) Ball Nut dimension is without seal at the both ends.

If the seals are required, Ball Nut dimension should be changed, in that case, please ask KSS. Some type of Ball Nuts cannot equip with seals, please ask KSS representative.

Note 3) The Rigidity values shown in the table are theoretical values of Ball Nut Rigidity calculated from the amount of Elastic Displacement under the following conditions.
Backlash type ; Apply the Axial load equivalent to 30% of the Basic Dynamic Load Rating Ca.
Preload type ; Apply the Preload equivalent to 5% of the Basic Dynamic Load Rating Ca.
For Axial load or Preload condition other than the above, see the formula in p-A823, you can calculate Rigidity using this formula.

Note 4) All models are Right-hand Screw. If Left-hand Screw is required, please ask KSS representative.

Note 5) Basic Load Rating and Rigidity for Backlash type and Preload type are described in the same cell.

Basic Load Rating N		Nut Rigidity N/μm
Dynamic Ca	Static Coa	
1000 / 640	3300 / 1650	164 / 138
		Preload type
		Backlash type