

BSSP0610 | Shaft dia. $\phi 6$ Lead 10mm

C5

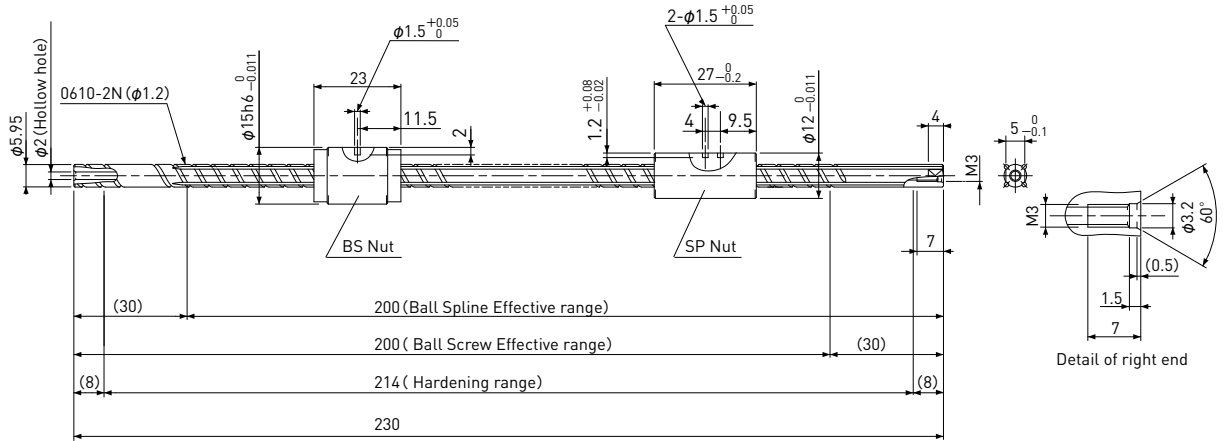

Ball Screw Specifications	
Accuracy Grade	JIS C5
Ball size	$\phi 1.2\text{mm}$
Number of thread	2
Thread direction	Right
Pitch circle dia.	6.30mm
Number of circuit	1.2×2
Basic Load Rating Dynamic : Ca	(650N)
Basic Load Rating Static : Coa	(900N)
Axial Play	Max 0.005 mm

Ball Spline Specifications	
Accuracy Grade	JIS C5
Basic Load Rating Dynamic : Cr	(750N)
Basic Load Rating Static : Cor	(1200N)
Basic Torque Rating Dynamic : Ct	(1.9 Nm)
Basic Torque Rating Static : Cot	(1.3 Nm)
Radial Play	Max 0.002 mm

Common Specifications		
Material	Shaft	SUJ2
	Nut	SCM415
Anti-rust treatment		Anti-rust Oil

Note 1) The detail will be provided by drawing.
 Note 2) Female thread on left end journal is not available.

[Re-works on Shaft-end]

Other parts can be attached by re-working the end journal, such as turning down, or male thread.

Re-works Example

