

BSSP0810 | Shaft dia. $\phi 8$ Lead 10mm

C5

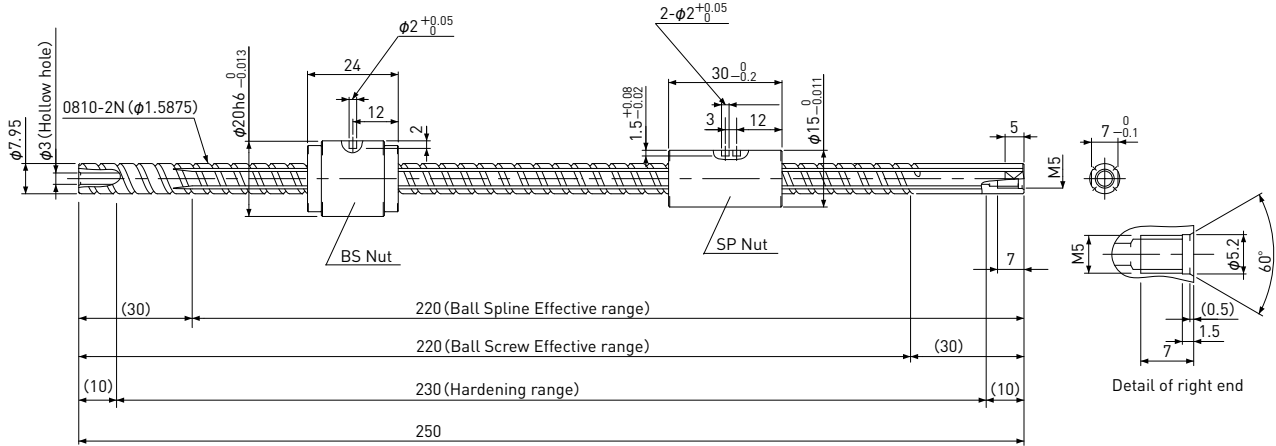

Ball Screw Specifications	
Accuracy Grade	JIS C5
Ball size	$\phi 1.5875\text{mm}$
Number of thread	2
Thread direction	Right 右
Pitch circle dia.	8.40mm
Number of circuit	1.65×2
Basic Load Rating Dynamic : Ca	(1400N)
Basic Load Rating Static : Coa	(2000N)
Axial Play	Max 0.005 mm

Ball Spline Specifications	
Accuracy Grade	JIS C5
Basic Load Rating Dynamic : Cr	(1000N)
Basic Load Rating Static : Cor	(1450N)
Basic Torque Rating Dynamic : Ct	(3.4Nm)
Basic Torque Rating Static : Cot	(2.4Nm)
Radial Play	Max 0.002 mm

Common Specifications		
Material	Shaft	SUJ2
	Nut	SCM415
Anti-rust treatment		Anti-rust Oil

Note 1) The detail will be provided by drawing.
 Note 2) Female thread on left end journal is not available..

[Re-works on Shaft-end]

Other parts can be attached by re-working the end journal, such as turning down, or male thread.

Re-works Example

